



Authorized Distributor:
Pacific Marine & Industrial
www.pacificmarine.net
info@pacificmarine.net



THE NEXT TULSA LEGEND!

INTRODUCING THE NEW 900 SERIES WINCH!

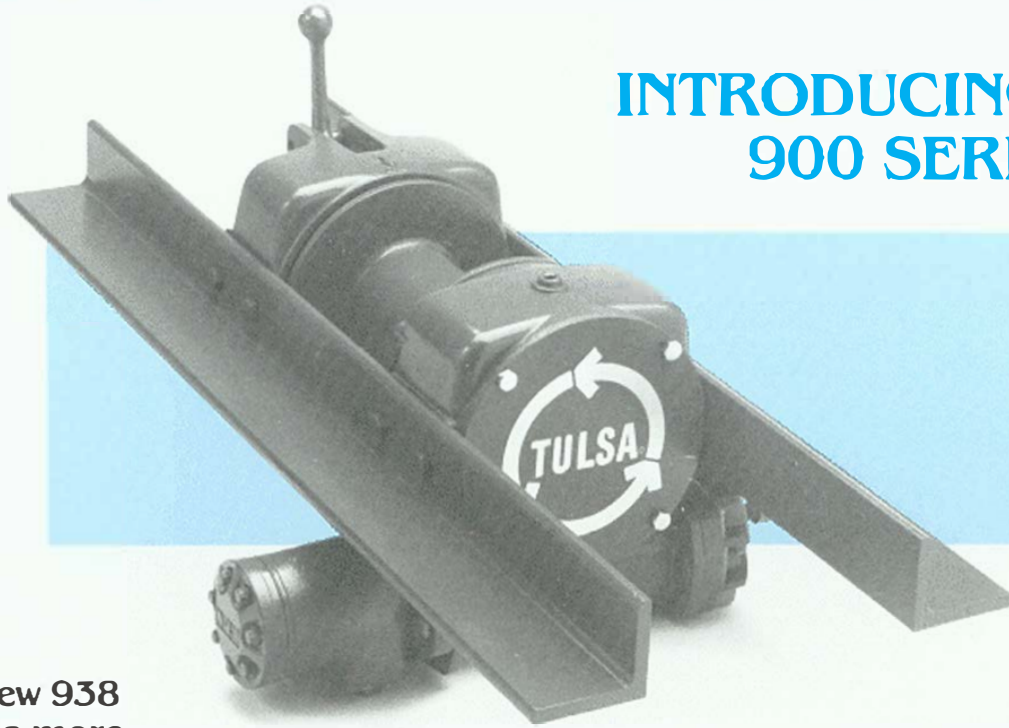

The new 938 offers a more

rugged, durable appearance to enhance your products. The 938 can be used on:

- **Equipment Trailers**
- **Garbage Packers**
- **Utility Trucks**
- **Wreckers**
- **Front Recovery**
- **Small Oilfield Trucks**
- SAE rated at 9000 Lbs. on the first layer, more than any other in its class!
- Aluminum housing, cover and end bracket for lightweight, greater strength.
- 1 1/2" Drum shaft for improved strength.
- Manganese bronze gear offers higher efficiency, smoother operation than any other winch in its class.
- Mounting dimensions are bolt-in interchangeable with competitive units.
- Ball bearings allow longer life, ease of service.
- Enclosed clutch with positive shifter.
- Optional multiple disk oil brake provides safety, long wear for hoisting and lifting applications.
- Mechanical or hydraulic power. Hydraulic motor bolts directly to winch housing.

Last year Tulsa Winch introduced the 1000 and 1200 winches. With features never seen before in small winches, these models have quickly captured an important share of the market.

Now Tulsa is proud to introduce the 938, with many of the same features of its' larger cousins—

INSTALLATION DIMENSIONS

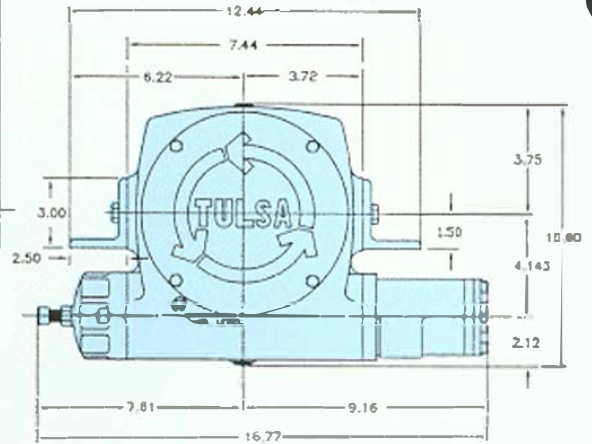
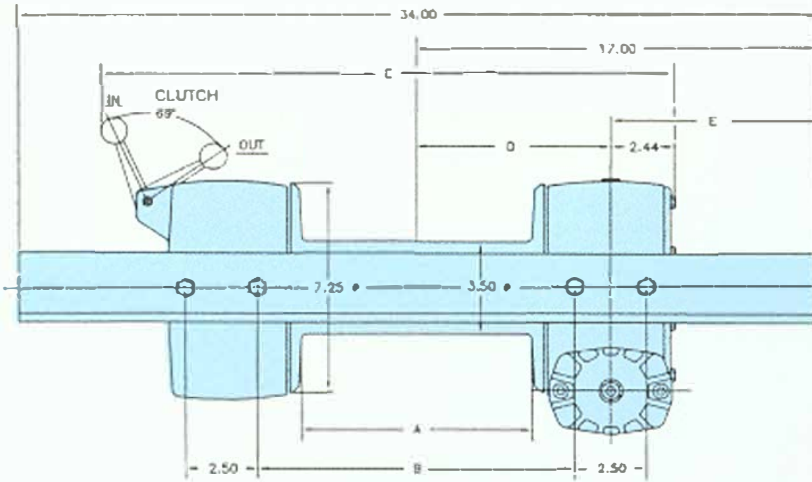

| A | B | C | D | E |
|-----|-------|-------|------|-------|
| 6" | 8.06 | 18.12 | 5.25 | 11.75 |
| 11" | 13.06 | 23.12 | 7.75 | 9.25 |

PERFORMANCE DATA

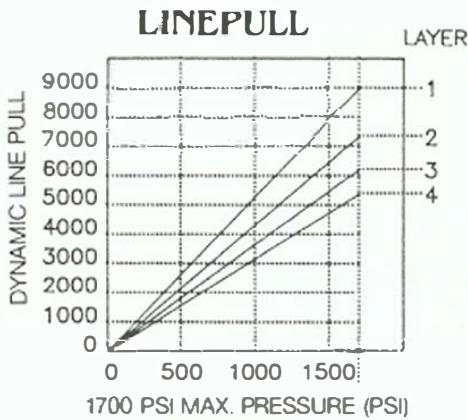

(FOR STATIC LINEPULLS, USE 68% OF DYNAMIC LINEPULLS)

| CABLE CAPACITY 1/16" CABLE (IN FEET) | | |
|--|------|-----|
| Layer | Drum | |
| | 6" | 11" |
| 1st | 14 | 25 |
| 2nd | 31 | 56 |
| 3rd | 51 | 93 |
| 4th | 74 | 135 |

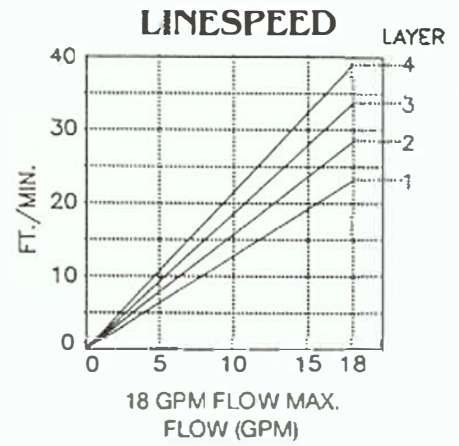

TWG

a DOVER company

TWG
PO Box 1130
Jenks OK 74037-1130 USA
Phone: 918-298-8300
www.dovertwg.com

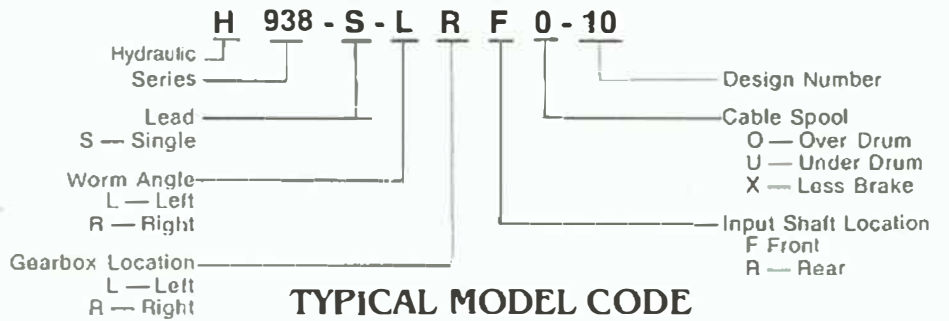

TYPICAL MODEL CODE



Authorized Distributor:
Pacific Marine & Industrial
www.pacificmarine.net
info@pacificmarine.net