



Tulsa Winch

MODEL 1200W WINCH



Authorized Distributor:
Pacific Marine & Industrial
www.pacificmarine.net
info@pacificmarine.net

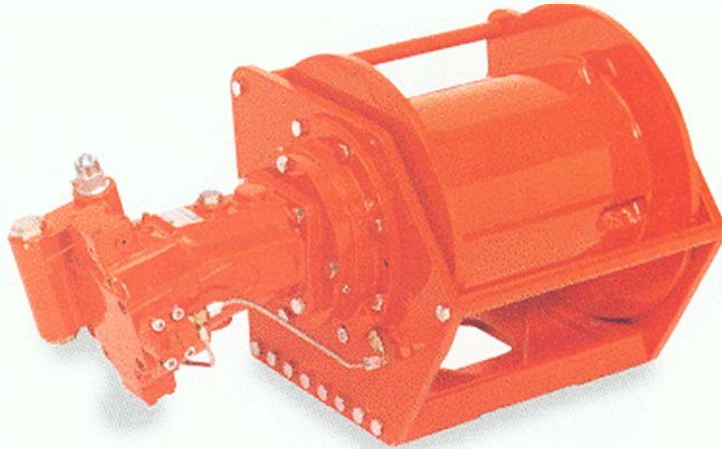

- Rated at 12,000 Pounds First Layer Linepull.
- Applications include truck-mounted cranes, rough-terrain cranes, drilling rigs, offshore cranes and fishing vessels.
- Available with four ratio and many motor options to provide optimum linespeed and linepull for your application.
- Integral spring-applied, hydraulically-released brake for static load holding. The brake has its own oil cavity to ensure long life, positive clutch engagement.
- A motor-mounted counterbalance valve provides positive dynamic braking.
- A symmetrical mounting bracket allows motor-mounting on either side.
- The cable drum is mounted on large-capacity ball bearings for smooth operation.
- Designed for easy maintenance and service.

Installation Dimensions



Authorized Distributor:
 Pacific Marine & Industrial
 www.pacificmarine.net
 info@pacificmarine.net

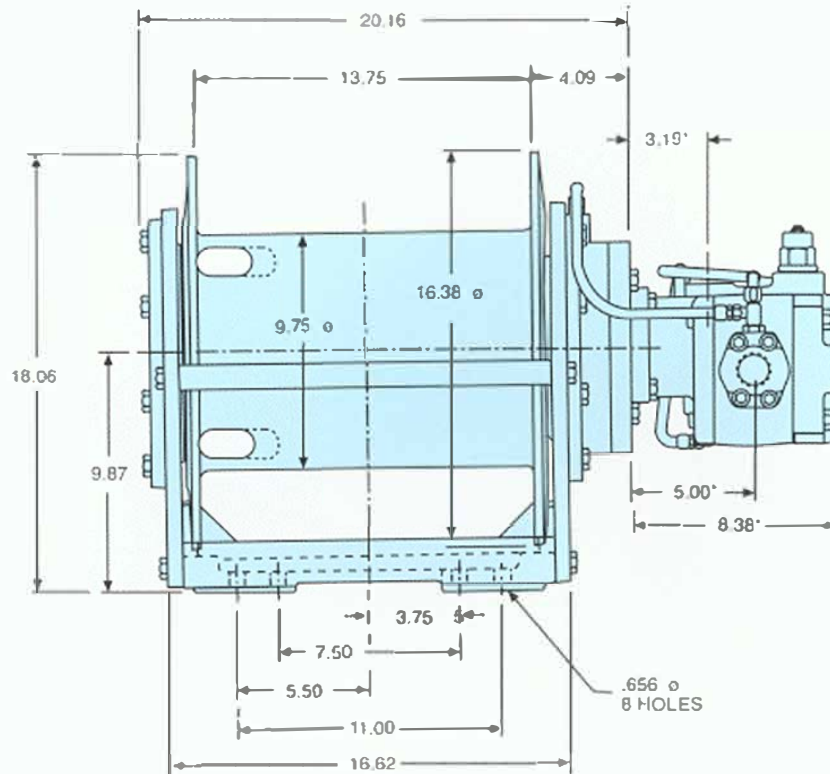

*Dimensions shown may vary slightly with different motors.

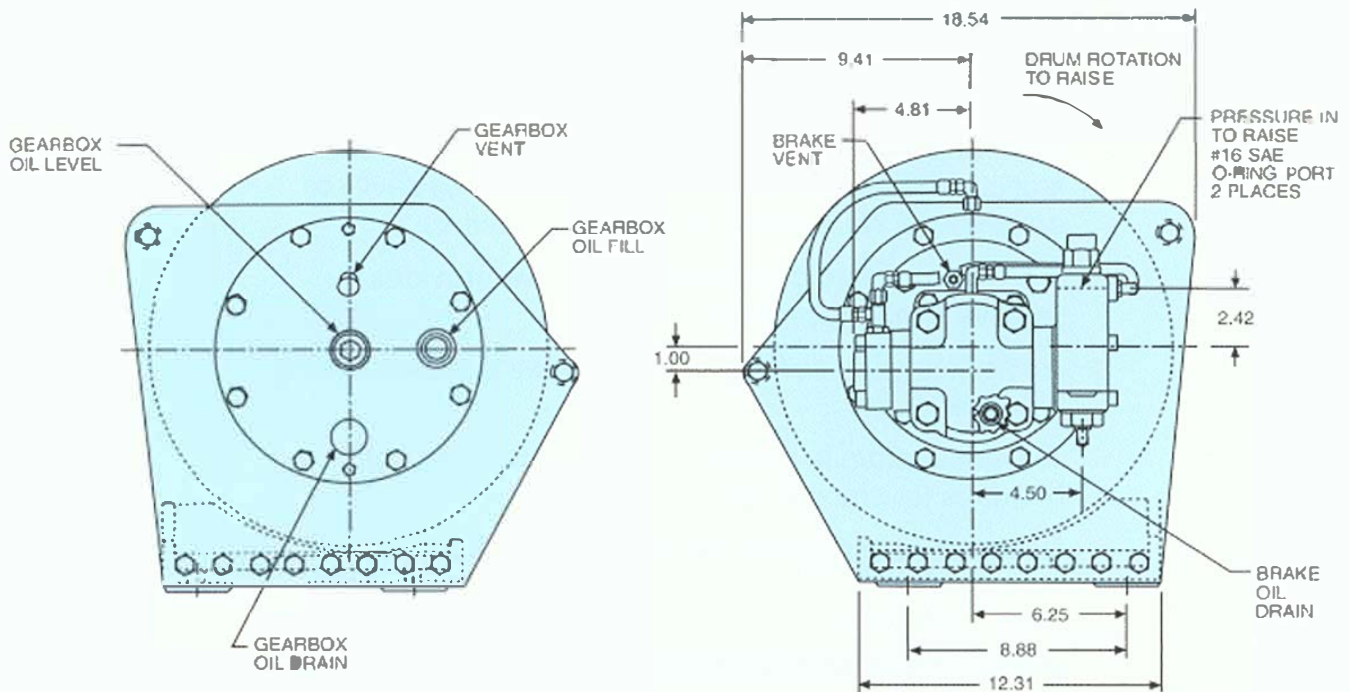

Performance Data



Authorized Distributor:
 Pacific Marine & Industrial
www.pacificmarine.net
info@pacificmarine.net

Layer	7/16" Rope		1/2" Rope		9/16" Rope		5/8" Rope	
	Linepull, lb.	Linespeed, FPM	Linepull, lb.	Linespeed, FPM	Linepull, lb.	Linespeed, FPM	Linepull, lb.	Linespeed, FPM
21:1 Ratio, WM51, 2 1/2" Gear, @3000 PSI and 60 GPM								
1	9,500	257	9,500	259	9,500	260	9,500	262
2	8,854	279	8,706	284	8,563	289	8,425	293
3	8,205	302	7,995	309	7,797	317	7,607	325
4	7,644	323	7,392	335	7,156	346	6,934	356
5	7,156	346	6,873	360	6,612	374	6,370	389
6	6,726	368	6,423	385				
21:1 Ratio, CL2000, 8.0 CID, @2500 PSI and 25 GPM								
1	9,500	86	9,500	87	9,500	87	9,500	88
2	8,854	94	8,706	95	8,563	97	8,425	98
3	8,205	101	7,995	104	7,797	106	7,607	109
4	7,644	108	7,392	112	7,156	116	6,934	120
5	7,156	116	6,873	121	6,612	125	6,370	130
6	6,726	123	6,423	129				
29.3:1 Ratio, WM51, 2 1/2" Gear, @2800 PSI and 60 GPM								
1	12,000	185	12,000	186	12,000	187	12,000	188
2	11,285	200	11,097	204	10,915	207	10,739	211
3	10,458	216	10,191	222	9,937	228	9,696	233
4	9,744	233	9,422	240	9,121	248	8,838	256
5	9,121	248	8,761	258	8,428	269	8,120	279
6	8,573	264	8,186	277				
29.3:1 Ratio, CL2000, 8.0 CID, @2350 PSI and 25 GPM								
1	12,000	62	12,000	63	12,000	63	12,000	64
2	11,169	68	10,982	69	10,802	70	10,628	71
3	10,350	73	10,086	75	9,835	77	9,596	79
4	9,643	79	9,325	81	9,027	84	8,747	87
5	9,027	84	8,670	87	8,341	91	8,036	94
6	8,484	89	8,102	93				
41.6:1 Ratio, WM51, 2" Gear, @2500 PSI and 60 GPM								
1	12,000	164	12,000	165	12,000	166	12,000	167
2	11,424	178	11,233	181	11,049	184	10,871	187
3	10,586	192	10,316	198	10,060	202	9,815	207
4	9,863	206	9,538	214	9,233	220	8,947	227
5	9,233	220	8,868	230	8,532	238	8,219	247
6	8,678	234	8,287	246				
59.1:1 Ratio, WM51, 1 3/4" Gear @2000 PSI and 60 GPM								
1	12,000	130	12,000	131	12,000	132	12,000	133
2	11,510	142	11,319	144	11,133	146	10,953	149
3	10,667	152	10,395	156	10,136	160	9,890	164
4	9,938	163	9,610	169	9,303	174	9,015	180
5	9,303	174	8,936	182	8,596	189	8,282	196
6	8,744	186	8,350	194				



Authorized Distributor:
Pacific Marine & Industrial
 www.pacificmarine.net
 info@pacificmarine.net

Cable Capacity

(Cumulative per layer in feet)

Cable size (in.)	Layer					
	1	2	3	4	5	6
7/16	83	172	269	373	484	603
1/2	72	152	239	332	433	541
9/16	65	137	216	302	395	
5/8	60	127	201	282	371	
1	37	80	130			
1-1/8	34	75	124			

1" and 1-1/8" poly rope require a special wedge.
 Consult Tulsa Winch for this item.

Model Code

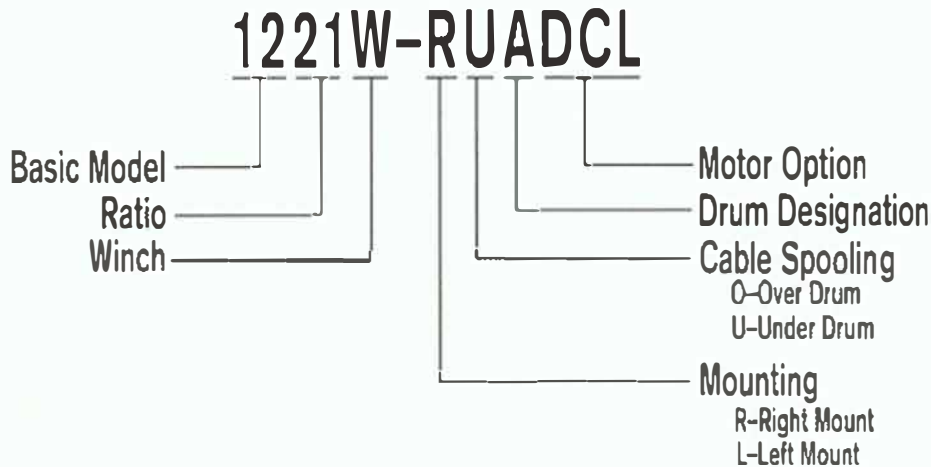

TWG
 PO Box 1130
 Jenks OK 74037-1130 USA
 Phone: 918-298-8300
 www.dovertwg.com