

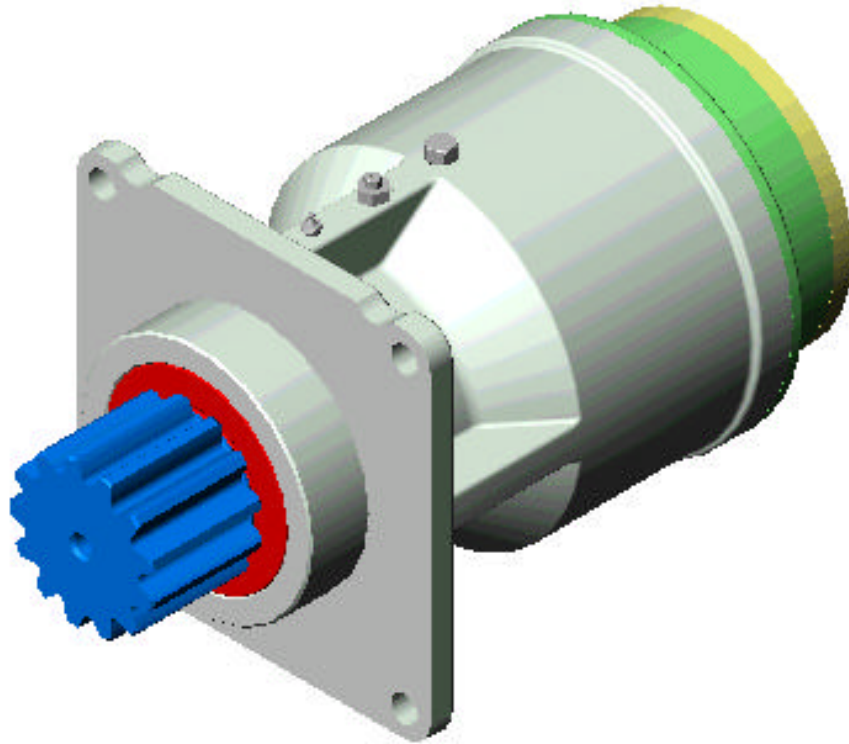

Authorized Distributor:  
Pacific Marine & Industrial  
www.pacificmarine.net  
info@pacificmarine.net



5200 SERIES  
6000 SERIES  
SWING DRIVE  
SERVICE MANUAL





This manual will primarily assist in disassembly and assembly procedures of major components for all 52 & 60 series Swing Drives. Item numbers, indicated in parentheses throughout this manual, refer to the Tulsa Winch Model 52 and 60 series exploded assembly drawing located in the back of this manual.

## LUBRICATION AND MAINTENANCE

Manufacturer recommends changing oil after first 50 hours of operation. Oil should be changed at 500-hour intervals thereafter. All gearboxes require GL-5 grade EP 80/90 gear oil for lubrication. Some units may be equipped with a grease fitting for lubrication of the output shaft bearings (pinion up applications). The shaft bearings should be greased sparingly at every 50 operating hours with a lithium or GP bearing lube. In pinion down applications, gearbox oil will lubricate Shaft bearings.

### OIL CAPACITIES:

	52	60
Pinion up:	70 Ounces	128 Ounces
Pinion down:	88 Ounces	100 Ounces

## DISASSEMBLY PROCEDURE FOR 52 & 60 SERIES SWING DRIVES

1. Remove drive from vehicle and drain gearbox lubricant by removing the drain plug **(31)**.
2. Remove the motor from the motor adapter **(30)**.
3. Remove the brake assembly from the gear housing assembly **(7)** by removing eight hexhead capscrews **(18)**. NOTE: Notice the position of the brake port in conjunction with the drain and fill holes in the housing for reassembly.
4. Inspect the brake housing o-ring **(14)** for damage. Replace if necessary.
5. Separate the motor adapter **(30)** from the brake housing **(15)** by removing eight capscrews **(32)**. NOTE: Notice the position of the motor mounting hole in relation to the brake release port for re-assembly. CAUTION: The motor adapter is spring-loaded and the capscrews should be loosened in a sequence that will allow an even load distribution on the motor adapter.
6. Inspect the motor adapter o-ring **(29)** for damage. Replace if necessary.
7. Remove the six springs **(33)**, piston **(25)**, and brake driver **(27)** from brake housing **(15)**. NOTE: On 52 series swingdrives notice the position of the dowel-pin hole in piston with respect to the brake release port for re-assembly. NOTE: A port-a-power can be used to assist in the removal of piston by slowly pressurizing the brake release port until piston clears the top of housing **(15)**. Remove stator plates **(19)** and friction discs **(20)** from the brake housing **(15)**. Inspect stator plates for excessive grooving or burn spots. Also, inspect friction discs for wear. Replace as required. (Ref. Fig. 1)
8. Inspect the piston o-rings **(22 & 23)** and the back-up rings **(21 & 24)** for damage, replace if necessary. (Ref. Fig. 2)
9. If applicable remove 2<sup>nd</sup> piston **(36)** from the brake housing **(15)**, inspect o-rings



(37 & 38) and back-up rings (39 & 40) for damage, replace if necessary. (Ref. Fig. 2) On 52 series swingdrive inspect bearing (41) & seal (42) in brake housing (15) replace if necessary.

10. Remove race (12) from input planet set (13).
11. Remove input planet set (13) from gear housing (7) by pulling straight up and out of the housing.
12. Remove retaining ring (13.4), press out the planet pins (13.3), remove the planet gear (13.2), and needle bearings (13.5), inspect for unusual wear. Replace as required.
13. Remove race (12) from output planet set (10).
14. Remove the output sun gear (11), from the output planet carrier (10.). Lift the output planet set out of the housing (7).
15. Remove the retaining ring (10.4). Press out the planet pins (10.3); remove the

planet gear (10.2) and needle bearings (10.5). Inspect for unusual wear. Replace as required.

16. Remove bearing lock nut (35) and lock washer (34).
17. Remove the pinion shaft (1) from the housing (7) inspect the pinion shaft, seal, and bearing for wear and replace if necessary. Remove the inboard bearing (9) and inspect for wear.
18. Remove outboard seal (2) and bearing (3) Inspect for wear and replace if necessary.

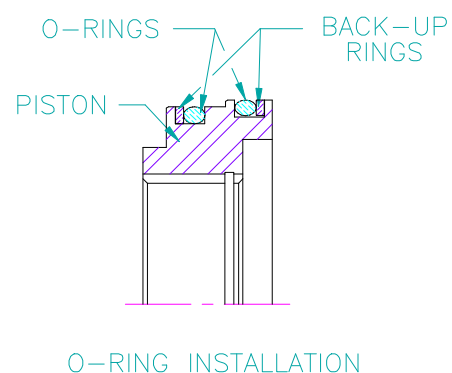
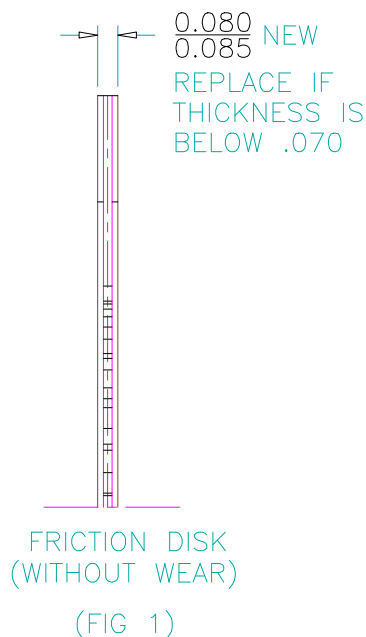

(FIG 2)



# ASSEMBLY PROCEDURE

## FOR 5200 & 6000 SERIES SWING DRIVES

1. Press the inboard and outboard bearing cup (**4 & 8**) into the gear housing (**7**) if replaced.
2. Grease pack the bearing cones (**9 & 3**) with EP-2 before installation.
3. Install the outboard cone (**3**) into the outboard cup (**4**). Press the seal (**2**) into the gear housing (**7**) from the outboard side.
4. Slide the output pinion (**1**) into the housing (**7**) from the outside.
5. Install the inboard bearing cone (**9**).
6. Apply Loc-Tite to pinion shaft and locknut.
7. Install the bearing lockwasher (**34**) then the bearing locknut (**35**). Torque locknut to 100 Ft. Lbs. Loosen and rotate pinion 90 degrees, re-torque locknut to 100 Ft. Lbs. (repeat this process 4 times) then re-tighten locknut to 100 Ft. Lbs. If the locknut is between tabs on the lockwasher always tighten until tabs align with slots in locknut. Secure locknut by bending tabs on lockwasher so that it engages locknut to prevent locknut from backing off. NOTE: Install a 5/8-11 bolt into the end of the pinion shaft on the outboard side and check the rolling torque. Preload of the bearing torque should be 75-85 In. Lbs.
8. Install the output carrier (**10**) into the gear housing (**7**). Install sun gear (**11**) and then the race (**12**) into output carrier (**10**).
9. Install the input carrier section (**13**) with race (**12**).
10. Assemble the brake section by first installing the o-ring (**14**) on the brake housing (**15**). Install eight capscrews (**18**) to the brake housing (**15**) and torque to 10 ft. lbs. NOTE: Notice the position of the brake port in conjunction with the drain and fill holes in the housing.
11. If applicable install piston (**36**) into brake housing (**15**). NOTE: Apply a slight film of oil on the o-rings and back-up rings before installation.
12. Insert the brake driver (**27**) into the assembled brake housing (**15**).
13. Install the stator plates (**19**) and friction disks (**20**) starting with one stator plate and alternating between friction disk and stator plate until six stator plates and five friction disks are used. NOTE: Soak friction disk in EP-90 oil before installation.
14. Carefully press the assembled piston (**25**) into the brake housing (**15**), taking care not to damage the o-rings. NOTE: Notice the position of the dowel pin hole in piston with the brake release port for correct assembly.
15. Install six springs (**33**) into the holes in the piston (**25**).
16. Mount the motor adapter (**30**) to the brake housing (**15**) with eight capscrews (**32**) checking to make sure the roll pin (**26**) is in line with the dowel hole in piston (**25**). NOTE: Notice the position of the motor mounting hole in relation to the brake release port for correct re-assembly.
17. Mount the motor to the adapter (**30**).
18. Fill the gearbox to desired level with EP-90 gear lube.



# 5200S

1	1	43379	SHAFT, OUTPUT, PINION
2	1	43382	SEAL, OIL
3	1	34773	CONE, BEARING
4	1	34772	CUP, BEARING
5	1	13050	BREATHER
6	1	42752	ADAPTER
7	1	43378	HOUSING, GEAR
8	1	43381	CUP, BEARING
9	1	43380	CONE, BEARING
10	1	4171	GEAR SET, OUTPUT
11	1	42303	GEAR, SUN, OUTPUT
12	2	41722	RACE </td
13	1	4170	GEAR SET, INPUT
14	1	939452	O-RING
15	1	42680	HOUSING, BRAKE
16	1	21128	FITTING, GREASE ZERK
17	1	939487	PLUG, O-RING
18	8	20522	CAPSCREW
19	6	42111	PLATE, STATOR
20	5	33564	DISC, FRICTION
21	1	42675	RING, BACK-UP
22	1	42672	O-RING
23	1	32186	O-RING
24	1	42337	RING, BACK-UP
25	1	42697	PISTON, BRAKE
26	1	27590	PIN
27	1	42683	DRIVER, BRAKE
28	1	41994	RING, RETAINING
29	1	33094	O-RING
30	1	42682	COVER, BRAKE
31	1	42392	PLUG, O-RING
32	8	939261	CAPSCREW
33	6	41718	SPRING, BRAKE
34	1	42333	LOCKWASHER, BEARING
35	1	42332	LOCKNUT, BEARING

PART NO. TAKEN FROM 81631

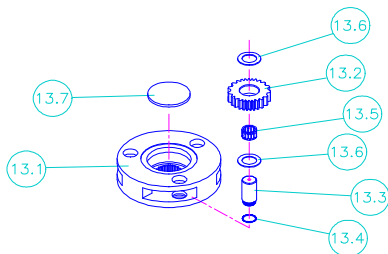
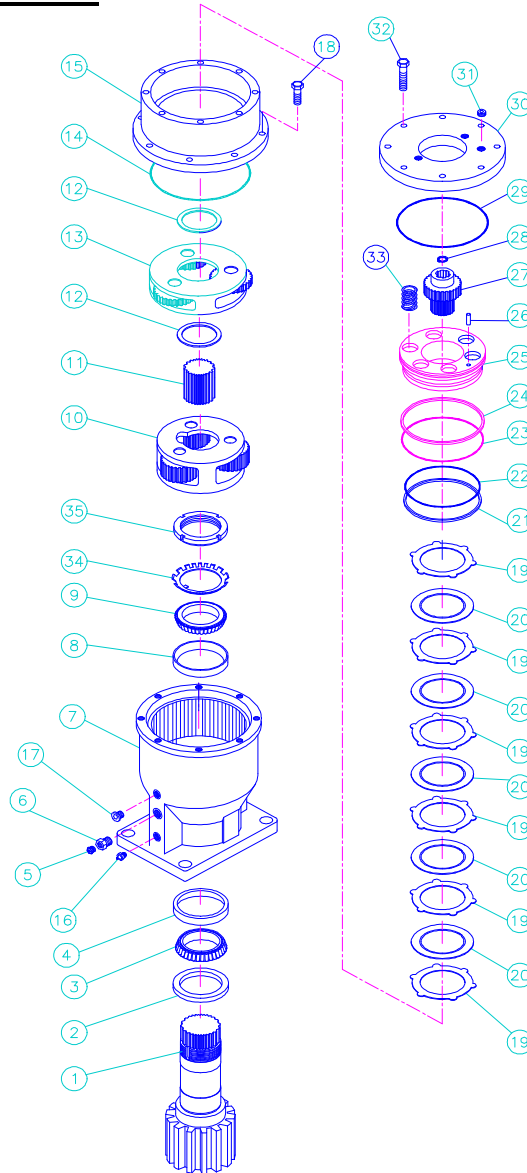

GEAR SET (ITEM 13 ABOVE)

13.1	1	42323	CARRIER, INPUT
13.2	3	42304	GEAR, PLANET, INPUT
13.3	3	41760	PIN, PLANET
13.4	3	41715	RING, RETAINING
13.5	3	30484	BEARING, NEEDLE
13.6	6	28771	RACE
13.7	1	41769	PLATE

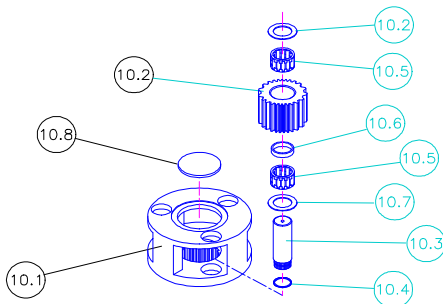

GEAR SET (ITEM 10 ABOVE)

10.1	1	42324	CARRIER, OUTPUT
10.2	3	42306	GEAR, PLANET
10.3	3	41747	PIN, PLANET
10.4	3	41716	RING, RETAINING
10.5	6	41717	BEARING
10.6	3	41739	SPACER
10.7	6	939249	RACE
10.8	1	41769	PLATE



# 6000S

1	1	42796	SHAFT, OUTPUT, PINION
2	1	42330	SEAL, OIL
3	1	42329	CONE, BEARING
4	1	34771	CUP, BEARING
5	2	13050	BREATHER
6	2	12208	BUSHING, PIPE
7	1	42857	HOUSING, GEAR
8	1	33115	CUP, BEARING
9	1	42331	CONE, BEARING
10	1	4171	GEAR SET, OUTPUT
11	1	42303	GEAR, SUN, OUTPUT
12	2	41722	RACE </td
13	1	4170	GEAR SET, INPUT
14	1	939452	O-RING
15	1	42897	HOUSING, BRAKE
16	1	42305	GEAR, SUN, INPUT
17	0	OMIT	OMIT
18	8	939261	CAPSCREW
19	6	42148	PLATE, STATOR
20	4	32765	DISC, FRICTION
21	1	42336	RING, BACK-UP
22	1	42335	O-RING
23	1	32186	O-RING
24	1	42337	RING, BACK-UP
25	1	42307	PISTON, BRAKE
26	1	29043	RING, RETAINING
27	1	42327	DRIVER, BRAKE
28	1	41994	RING, RETAINING
29	1	33094	O-RING
30	1	42712	COVER, BRAKE
31	2	939487	PLUG, O-RING
32	8	30076	CAPSCREW
33	6	41718	SPRING, BRAKE
34	1	42333	LOCKWASHER, BEARING
35	1	42332	LOCKNUT, BEARING
36	1	42896	PISTON, BRAKE
37	0	OMIT	OMIT
38	0	OMIT	OMIT
39	0	OMIT	OMIT
40	0	OMIT	OMIT
41	1	42632	BEARING
42	1	11637	SEAL, OIL

PART NO. TAKEN FROM 81459

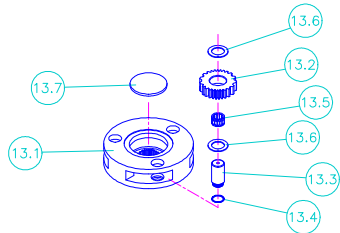
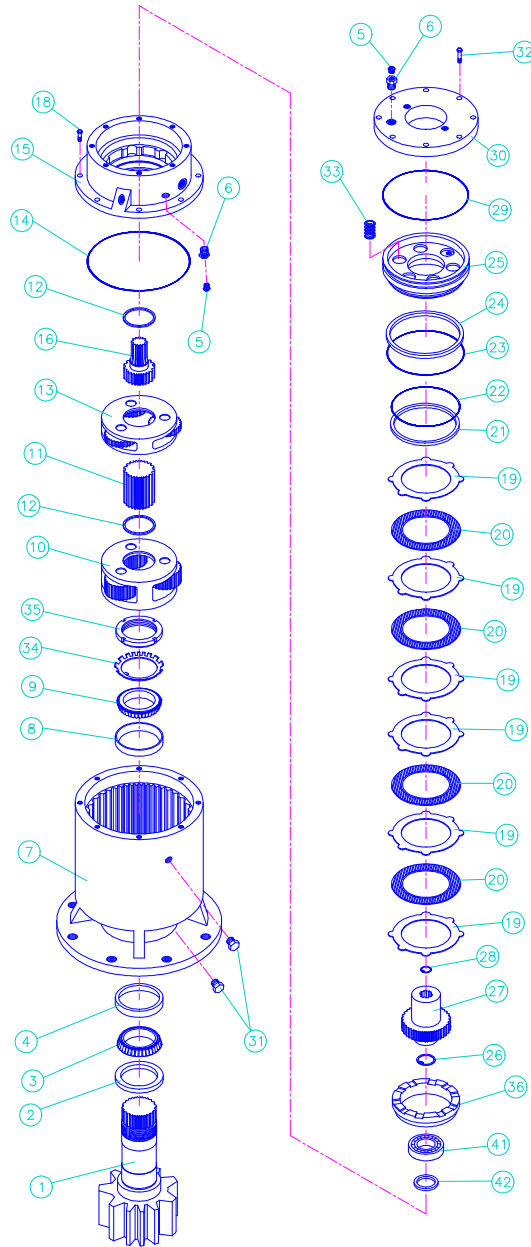

GEAR SET (ITEM 13 ABOVE)

13.1	1	42323	CARRIER, INPUT
13.2	3	42304	GEAR, PLANET, INPUT
13.3	3	41760	PIN, PLANET
13.4	3	41715	RING, RETAINING
13.5	3	30484	BEARING, NEEDLE
13.6	6	28771	RACE
13.7	1	41769	PLATE

GEAR SET (ITEM 10 ABOVE)

10.1	1	42324	CARRIER, OUTPUT
10.2	3	42306	GEAR, PLANET
10.3	3	41747	PIN, PLANET
10.4	3	41716	RING, RETAINING
10.5	6	41717	BEARING
10.6	3	41739	SPACER
10.7	6	939249	RACE
10.8	1	41769	PLATE

