

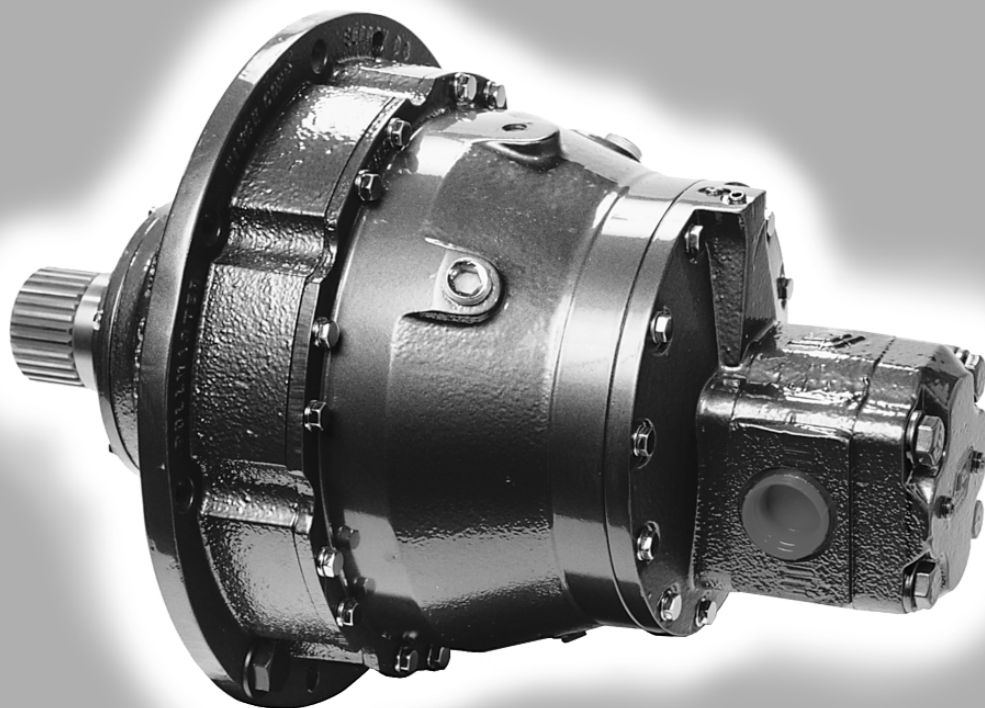

Authorized Distributor:
Pacific Marine & Industrial
www.pacificmarine.net
info@pacificmarine.net

PLANEMATIC DRIVES



EQUAL SPEED OR RAPID REVERSE

The Logical Choice

PULL

MASTER



INSTALLATION DIMENSIONS P50 SERIES

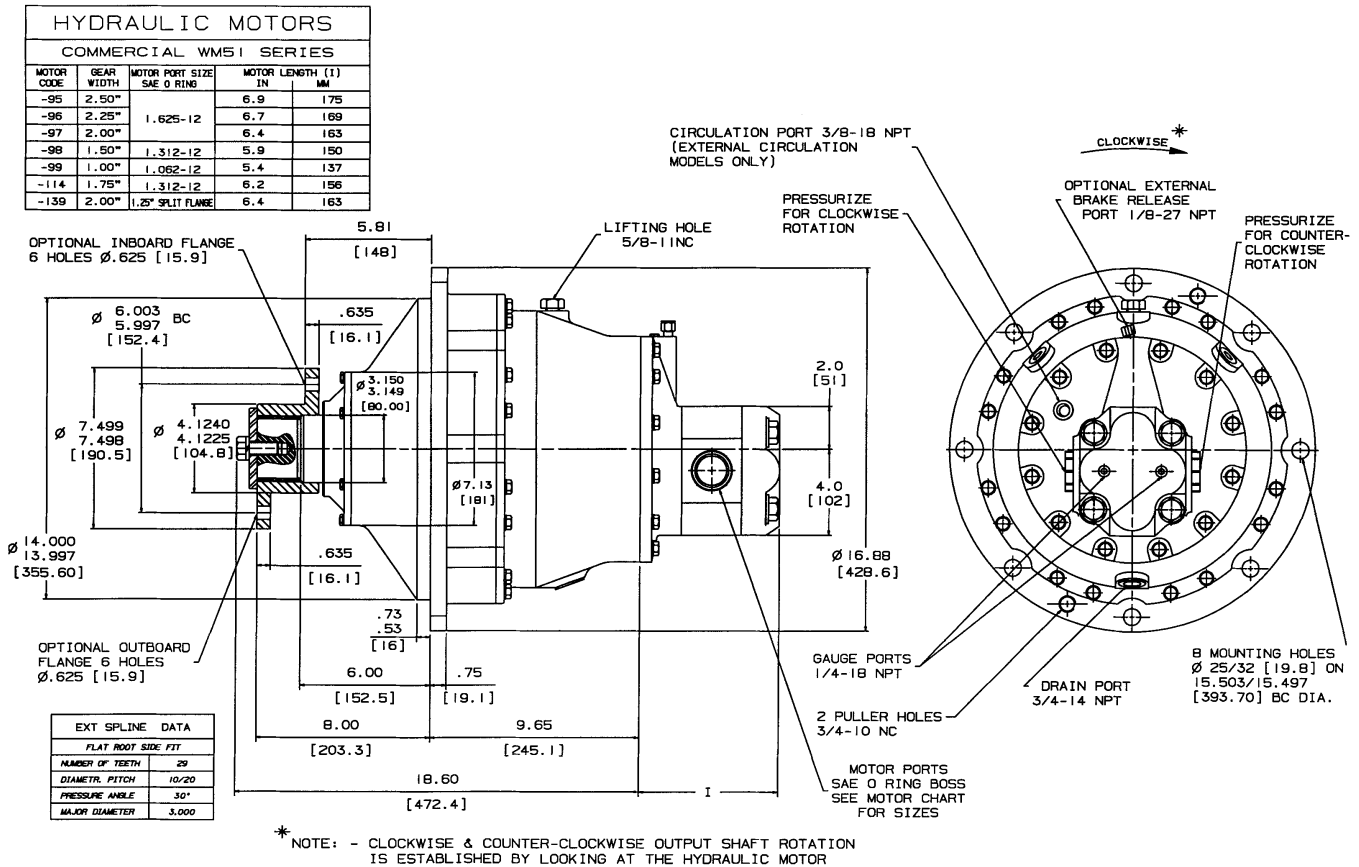

INSTALLATION DIMENSIONS P136 SERIES

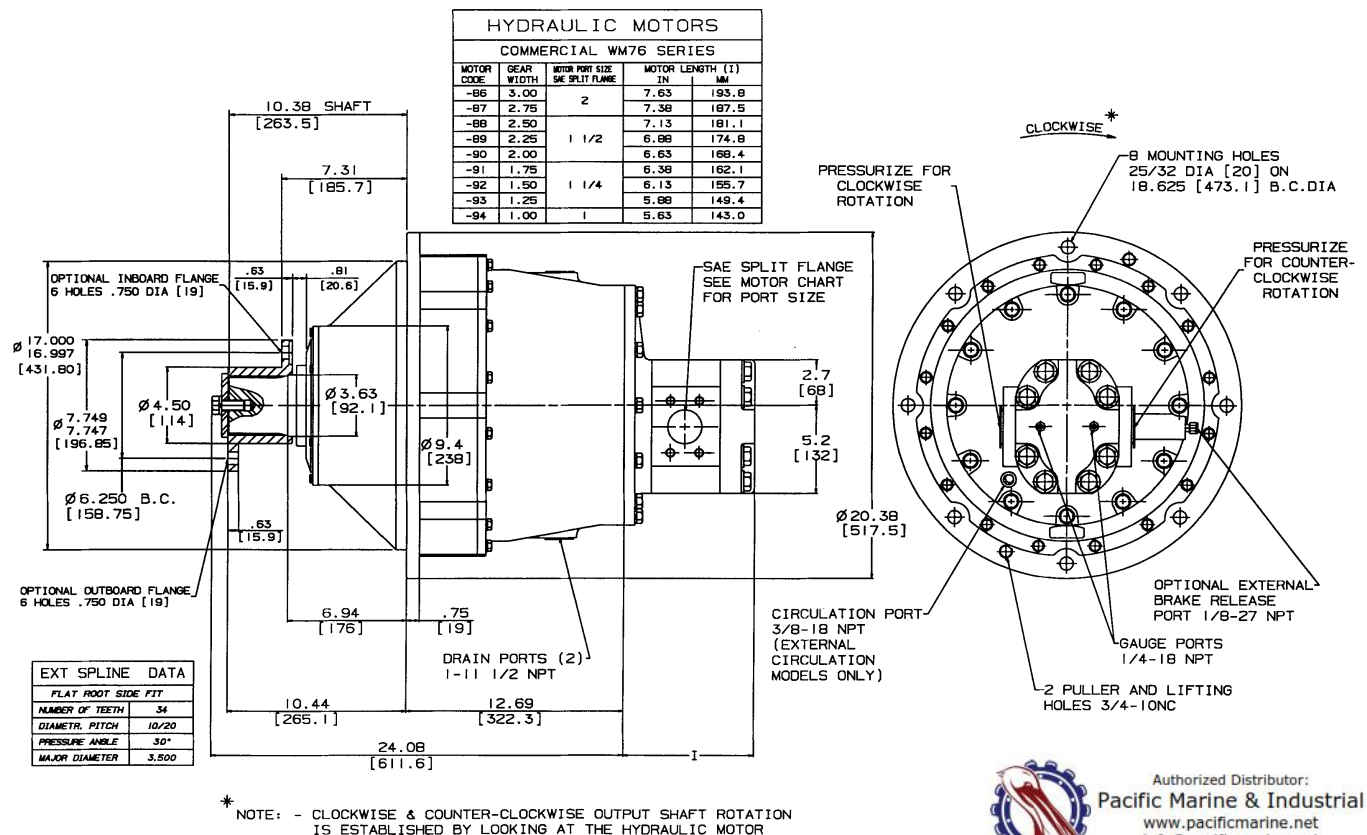

Authorized Distributor:
Pacific Marine & Industrial
www.pacificmarine.net
info@pacificmarine.net

PULLMASTER PLANEMATIC DRIVES

Pullmaster Planematic Drives are high performance, high efficiency reduction units complete with hydraulic motor and automatic brake. The brake is spring applied and pressure released and has static and dynamic function. Pullmaster Planematic Drives are available in many configurations. These include equal speed forward and reverse, high-speed reverse and brake effective in both directions. Two standard sizes are available: Output shaft torque of 50,000 lb-in (5,649 Nm) and 135,937 lb-in (15,359 Nm).

● **PM SERIES – Equal Speed in Both Directions:**

This unit offers maximum torque in both directions of rotation. Standard shaft rotation is clockwise when looking at the hydraulic motor end of the unit. The automatic disc brake functions in the opposite direction.

Units with brake effective in both directions, which are typically used in swing drive applications, come standard with a brake delay to reduce excessive shock loads when stopping a large swing drive load.

● **PH SERIES – Rapid Reverse:**

This unit offers reversing speeds approximately 4.5 times faster than forward rotation speeds. Reverse output torque is reduced by the same factor. This function is achieved automatically by eliminating the primary reduction stage while operating in reverse rotation. Standard forward rotation is clockwise when looking at the hydraulic motor end of the unit. The automatic disc brake functions in the opposite direction.

PERFORMANCE

Model	Hydraulic Pressure	Hydraulic Volume	Output Torque		Output RPM *	
			Forward	Reverse	Forward	Reverse
PM50	2,200 psi 152 bar	50 gpm 189 l/min	50,000 lb-in 5,649 Nm	50,000 lb-in 5,649 Nm	48	48
PH50	2,200 psi 152 bar	50 gpm 189 l/min	50,000 lb-in 5,649 Nm	11,539 lb-in 1,304 Nm	48	208
PM136	2,500 psi 172 bar	115 gpm 435 l/min	135,937 lb-in 15,359 Nm	135,937 lb-in 15,359 Nm	49	49
PH136	2,500 psi 172 bar	115 gpm 435 l/min	135,937 lb-in 13,359 Nm	29,127 lb-in 3,291 Nm	49	229

* External circulation models only

OPTIONS

● **Hydraulic Motor**

Standard motor for a P50 Planematic Drive is a WM51 gear motor with a displacement of 5.1 cubic inches. Other displacement motors are available as an option to change the output performance of the unit. Standard motor for a P136 Planematic Drive is a WM76 gear motor with a displacement of 12.3 cubic inches. Other displacement motors are available as an option. When high-pressure systems are used, hydraulic piston motors can be used as an option. Contact the factory for performance specifications using different motors.

● **External Brake Release**

The disc brake of Pullmaster Planematic Drives functions automatically. For operations where it is necessary to release the brake independently, an external brake release is available.

● **Output shaft**

Standard units are supplied with a splined output shaft. Keyed shaft or splined flanges are available as options. Other output shafts will be considered for quantity orders.

● **Reduction Ratio**

Output performance can be altered through the use of different planetary reductions. Contact the factory with your requirements.

Calculations for Overhung Load Ratings

The magnitude and location of a load is dependent on the following factors:

		P50 Series	P136 Series
SF =	service factor	Table A	Table A
AF =	application factor	Table B	Table B
a =	bearing geometry constant	-3.1	-0.295
T =	basic thrust load	25,300	14,500
c =	basic load constant	51,000	133,800
L =	allowable overhung load in lbs.		
y =	distance of load center to mounting face in inches		

Allowable thrust or tension load in lbs. = T x SF

$$L = \frac{c \times SF}{(y+a)AF} = lbs$$

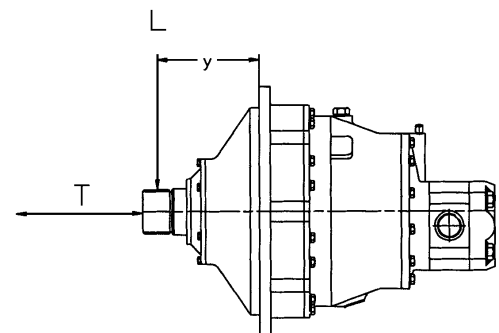

Table A		Table B	
24 hr. Day, continuous duty, full load	0.75	Chain Drive	1.00
8 hr. Day, continuous duty, full load	1.00	Gear	1.25
3 hr. Day, intermittent duty, full load	1.50	V-belt	1.50
Intermittent duty at variable loads, up to full load occasionally	2.68	Flat belt	2.50

EXPLANATION OF MODEL CODING

SERIES P X X X - X - XX - X

BASIC UNIT

P = Planematic Drive

TYPE OF UNIT

M = Equal Speed
H = High Speed Reverse

SIZE OF UNIT

50 = 50,000 lb-in output torque
136 = 135,937 lb-in output torque

REDUCTION RATIO Used for non-standard reductions only

TYPE OF BRAKE

Clockwise & Counter Clockwise rotation of shaft established by looking at the motor.

- 3 = Automatic brake, clockwise shaft rotation, internal circulation flow
- 4 = Automatic brake, clockwise shaft rotation, external brake release, internal circulation flow
- 5 = Automatic brake, counter clockwise shaft rotation, external brake release, internal circulation flow
- 6 = Automatic brake, counter clockwise shaft rotation, internal circulation flow
- 7 = Automatic brake, clockwise shaft rotation, external circulation flow
- 8 = Automatic brake, clockwise shaft rotation, external brake release, external circulation flow
- 9 = Automatic brake, counter clockwise shaft rotation, external brake release, external circulation flow
- 10 = Automatic brake, counter clockwise shaft rotation, external circulation flow
- 11 = Brake effective in both directions, external circulation flow
- 17 = Brake effective in both directions, external circulation flow, external brake release

Automatic Brake = Spring applied, automatically released by the hydraulic pressure of the motor

HYDRAULIC MOTOR

- 86 = WM76 hydraulic gear motor (3" gear) 12.3 cid
- 97 = WM51 hydraulic gear motor (2" gear) 5.1cid

OUTPUT SHAFT

- 1 = Splined output shaft
- 2 = Keyed output shaft
- 3 = Splined output shaft with inboard flange adaptor
- 4 = Splined output shaft with outboard flange adaptor

TYPICAL HYDRAULIC CIRCUIT

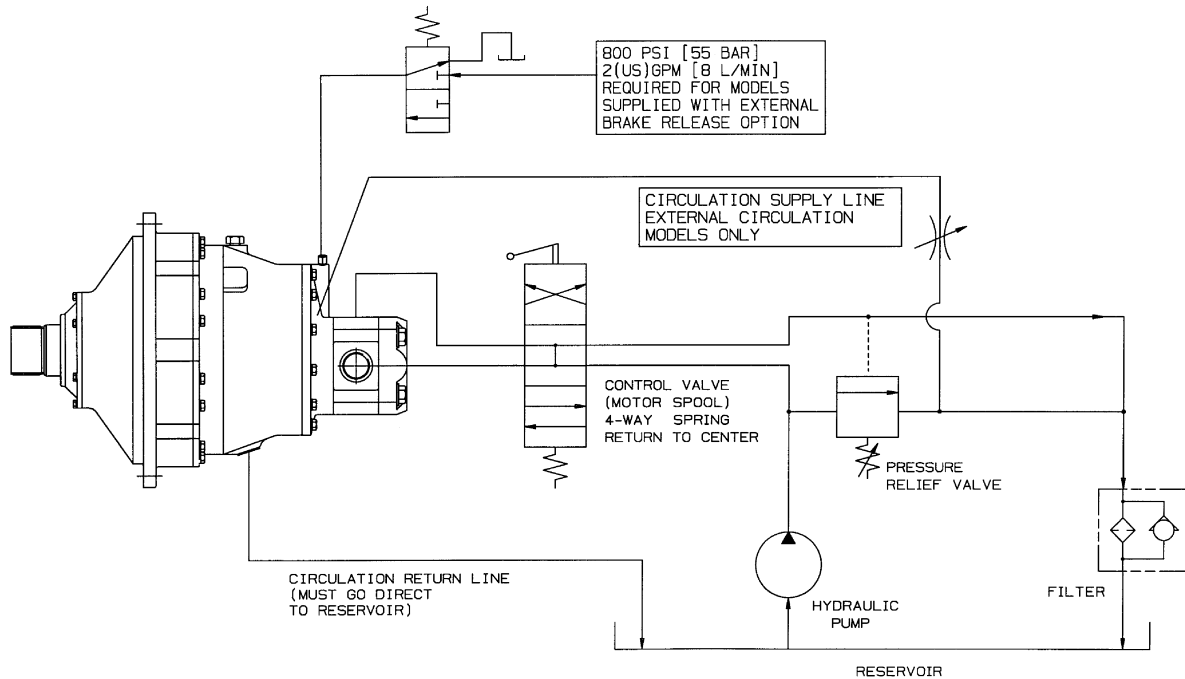

DISTRIBUTOR

Authorized Distributor:
Pacific Marine & Industrial
www.pacificmarine.net
info@pacificmarine.net

Specifications / Dimensions subject to change without notice and incurring obligation.

PMC 292 Pub 991101



PULLMASTER WINCH CORPORATION

8247 - 130th Street, Surrey, B.C. Canada V3W 7X4
Telephone: (604) 594-4444 • Fax: (604) 591-7332
http://www.pullmaster.com • E-mail: info@pullmaster.com

PRINTED IN CANADA