



# London LED

LED engine room light 12V or 24 V



## Description

Powerful light in the most strongly room on board. There is no alternative for applications under extrem mechanical strain! For a dynamic lighting in your engine room explore our new slim LED surface mount light with an installation on wall or ceiling. The moulded housing provides optimal result for the IP65 rating.

This series is available for all markets worldwide.

## Technical specifications

### Application

Interior and exterior

### Housing

Polycarbonate IP 65

### Mounting

Requires two mounting screws (included)

### Light Source

7 W LED included

### Electrical specification

12V or 24 V

### Diffuser

Specially developed precision optic



Authorized Distributor:  
**Pacific Marine & Industrial**  
[www.pacificmarine.net](http://www.pacificmarine.net)  
[info@pacificmarine.net](mailto:info@pacificmarine.net)

## Illustrations

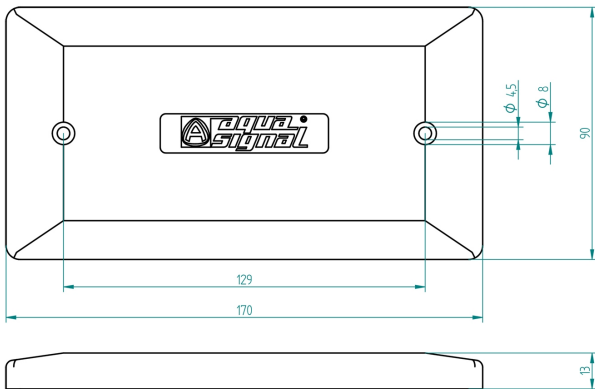

## Images

