



# Flashing light

High intensity flashing lights



## Description

Flashing lights are designed in different colours for all general warning purposes e.g. "Huge Vessel Light" or "Dangerous Cargo Light". The Flashing lights fulfil all requirements of IMO Anti Collision Regulations and local rules.

The high intensity Flashing lights with their special plastic housing come with several flash rates. You can choose between 60, 120 or 180 flashes per minute.

## Technical specifications

### Light Source

Xenon

### Dimensions

W: 153 H: 240

### Optic

Xenon strobe tube is included and covered by a coloured globe made of Apec (special Polycarbonate).

### Housing

Mat black PBT plastic (Pocan) base.

### Electrical specification

Complete electronic including the xenon strobe tube is located in the base part of the housing and available in 60, 120 or 180 flashes per minute. The fixture is equipped with one polyamide cable entry M20.

### Mounting

With 2 screws at the base part (screws not included)



Authorized Distributor:  
Pacific Marine & Industrial  
[www.pacificmarine.net](http://www.pacificmarine.net)  
[info@pacificmarine.net](mailto:info@pacificmarine.net)

## Illustrations

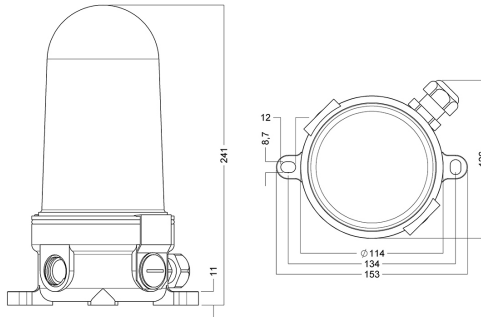

## Images



Authorized Distributor:  
**Pacific Marine & Industrial**  
[www.pacificmarine.net](http://www.pacificmarine.net)  
[info@pacificmarine.net](mailto:info@pacificmarine.net)