

EL40

Emergency LED sign



Description

EL40 is an emergency LED sign with a modern compact design with a focus at low building heights. It is available as recessed (EL40-R) or surface (EL40-S) mounted versions. Frames are delivered in polished or in white painted stainless steel. EL40 is available in wide selection of signs and it can easily be added to custom-made signs on request. It has an IP67 design and is delivered with IP67 Wieland quick connector or with Wago Midi IP20 quick connectors. It is designed for an easy installation with quick connector and fixing with 4 self-tapping suspension screws. Battery back-up versions are also available, both as recessed and surface-mounted versions. The battery back-up versions have bodyset, battery, inverter, indicator diode and cover included. Just relevant sign to be ordered in addition. Build your own light! Order your EL40 Exit Sign luminaire in three steps and build your individual light: Select body with suitable connector IP (A-items, 2 codes) Select cover colour and type for Recessed or Surface mounting. Select needed sign from selection of single and double-sided. Optional: Add a quick connector for customer's supply cable, for IP20 QCA use 1550420 = QC WAGO CONN_PLUG 3P and for IP67 QCW use 15350201 = WIELAND FEMALE PLUG RST20i3 IP68 (ø6-10 MM)

Technical specifications

Available variants

EL40 is available both as recessed (-R) and surface-mounted (-S) versions with and without battery back-up. The battery back-up versions have bodyset, battery, inverter, indicator diode and cover included. Just relevant sign to be ordered in addition. For versions without battery, bodyset, cover and sign need to be ordered.

Design

According to rules of maritime classification societies and relevant standards

Frame

Stainless steel polished (PS) or white powder coated (WH)

Mounting

4 pre-installed screws, Weight ~1kg with sign.

Connection

Connection cable with WIELAND-RST20i3 3-pole plug IP67 or Wago Midi IP20



Authorized Distributor:
Pacific Marine & Industrial
www.pacificmarine.net
info@pacificmarine.net

Sign

PMMA. Sign/Pictogram on customer requirements

IP class

IP67 with Wieland and IP20 with Wago quick connector

Light Source

Linear LED, 1,7 W,

Voltage / Frequency

220-240Vac / 50 and 60Hz

Temperature range

-25°C to +55°C

Illustrations

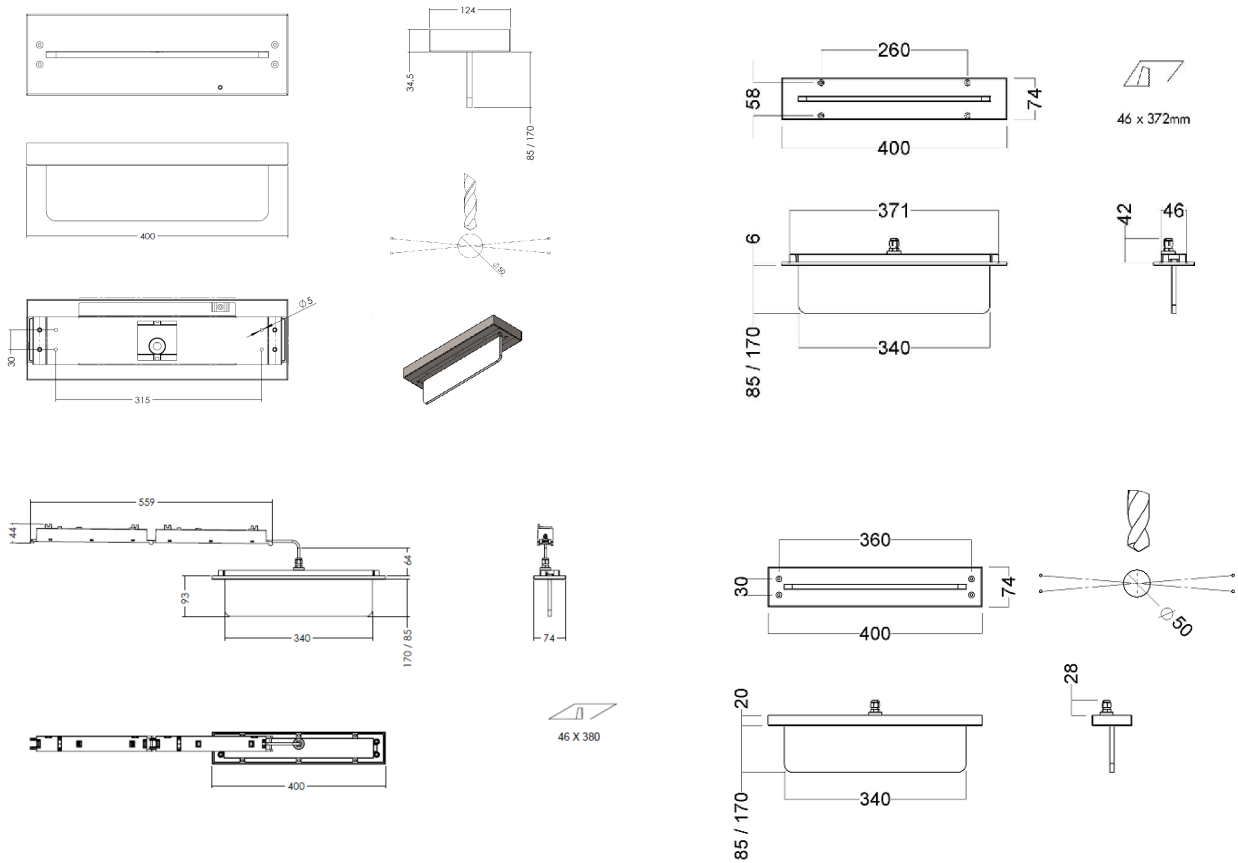

Images

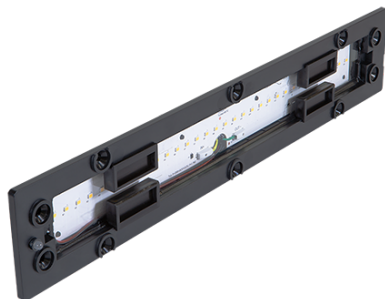

Authorized Distributor:
Pacific Marine & Industrial
www.pacificmarine.net
info@pacificmarine.net



Authorized Distributor:
Pacific Marine & Industrial
www.pacificmarine.net
info@pacificmarine.net