

E85-R(M)

Escape route recessed



Description

Emergency and Escape route light for recessed mounting based on LED technology. Housing in aluminium and zink coated steel sheet. Two options for reflectors. C reflector for corridors and WB (wide beam) reflector for room/area illumination. Available in White. Other colours on request.

Technical specifications

Application

For escape route or anti panic lighting

Design

DNV approved design according to maritimeclassification societies, additional IEC/ISO

Housing

Die casted aluminium recessed mounted,component plate in steel

Finish

Housing white powder coated RAL 9016

Optic

Corridor C or Wide beam WB for anti panic lighting

Electrical specification

Electronic ballast 220-240V, 50-60HzDelivered with 1 hour (E1) or 3 hour (E3) integratedbattery. Option for centralized battery 230V (Z). S = Standard ST = Selftest DALI = addressable system Z = 230V central battery system

Light Source

LED

Mounting

To be fixed with 4 screws.For B0 or B15 fire classification, look at service manual.

Connection

Back plate with double grommet and 2 knockouts,one each side.5×2×2.5 mm² push in terminal.



Authorized Distributor:
Pacific Marine & Industrial
www.pacificmarine.net
info@pacificmarine.net

Illustrations

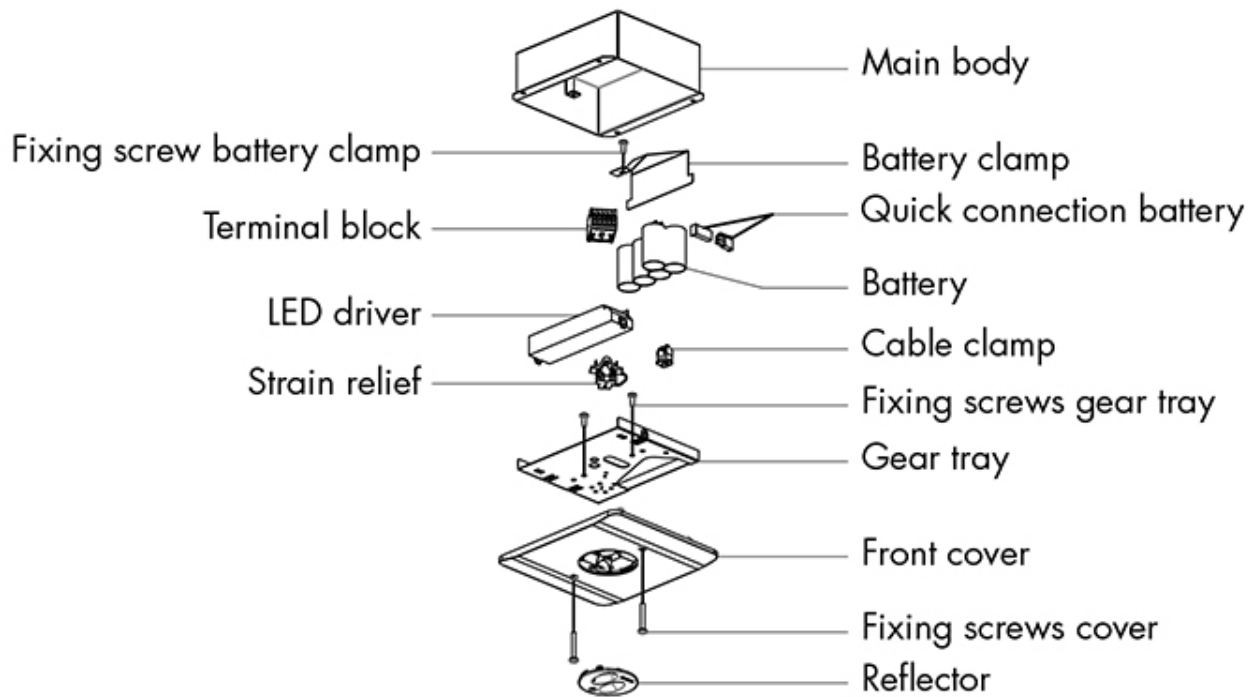
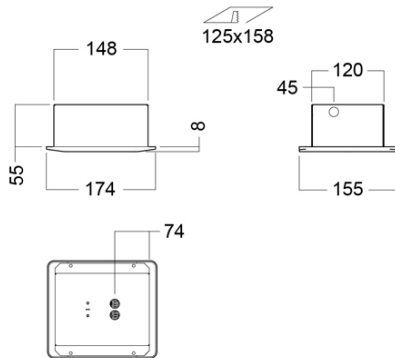

Images

