

---

# BRADEN<sup>®</sup>

---

## HP80A

### HYDRAULIC RECOVERY WINCH

# PRELIMINARY

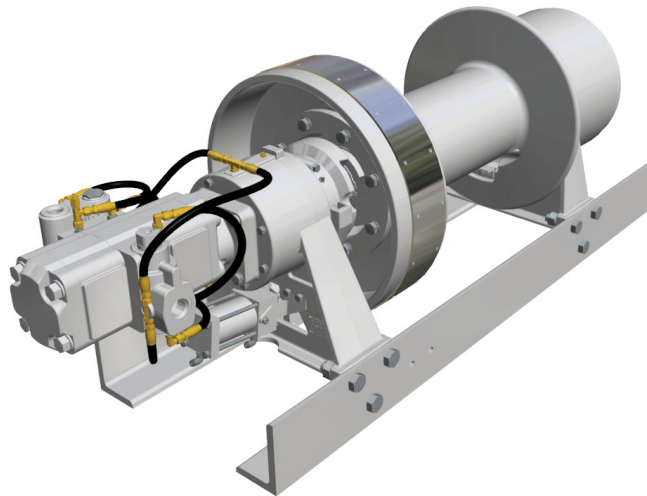

### INSTALLATION, MAINTENANCE AND SERVICE MANUAL

---



Authorized Distributor:  
Pacific Marine & Industrial  
[www.pacificmarine.net](http://www.pacificmarine.net)  
[info@pacificmarine.net](mailto:info@pacificmarine.net)

LIT2576\_R1\_07-2012  
PRINTED IN U.S.A.

**PACCAR WINCH**  
P.O. Box 547 Broken Arrow, OK 74012  
Tel 918-251-8511 / Fax 918-259-1575  
[www.paccarwinch.com](http://www.paccarwinch.com)

Pacific Marine & Industrial - [www.pacificmarine.net](http://www.pacificmarine.net)



# TABLE OF CONTENTS

FOREWORD .....	4
GENERAL SAFETY RECOMMENDATIONS .....	5
THEORY OF OPERATION .....	6
WINCH INSTALLATION .....	8
HYDRAULIC CIRCUIT .....	10
WIRE ROPE INSTALLATION .....	11
PRE-DELIVERY CHECK LIST .....	12
WINCH OPERATION .....	12
DRUM CLUTCH OPERATION .....	14
AUXILIARY RIGGING .....	16
PREVENTIVE MAINTENANCE.....	17
RECOMMENDED PLANETARY GEAR OIL.....	19
TROUBLESHOOTING .....	20
SERVICE PRECAUTIONS.....	23
RECOMMENDED BOLT TORQUE .....	23
WINCH DISASSEMBLY .....	24
HP80A TOP LEVEL ASSEMBLY .....	28
PLANETARY CARRIER SERVICE, PRIMARY .....	31
PLANET CARRIER SERVICE, INTERMEDIATE .....	33
PLANET CARRIER SERVICE, FINAL.....	35
OVERRUNNING CLUTCH SERVICE .....	37
HP80A ROTATION CHANGE.....	38

Safety Informational callouts used in this manual include:

## **WARNING**

**WARNING** – This emblem is used to warn against hazards and unsafe practices which could result in severe personal injury or death if proper procedures are not followed.

## **CAUTION**

**CAUTION** – This emblem is used to warn against potential or unsafe practices which could result in personal injury or product or property damage if proper procedures are not followed.

# FOREWORD

Read and understand this manual before operating or servicing your BRADEN winch. Retain this manual for future reference.

The minimum service intervals specified are for the operating hours of the prime mover.

This manual contains installation, operation and preventive maintenance instructions for most current model BRADEN Planetary Recovery winches. As there are many product variations, you must become familiar with your BRADEN winch to fully benefit from the information contained within this publication.

Some illustrations in this manual may show details or attachments that may be different from your winch, and some components may be removed for illustrative purposes.

Whenever a question arises regarding your BRADEN winch or this manual, please contact your nearest BRADEN distributor or the PACCAR Winch Division Product Support Department at:

Telephone- 1-918-251-8511  
08:00-16:30 Central Time Zone, Monday thru Friday  
FAX- 1-918-259-1575  
[www.paccarwinch.com](http://www.paccarwinch.com)

Provide the complete winch model and serial number when making inquiries.

## Parts and Service

BRADEN provides parts and service through a network of BRADEN distributors. Parts and service are not available directly from the PACCAR Winch Division. For the name of your nearest BRADEN distributor, consult your local phone directory, or contact BRADEN as described above.

## UNIT IDENTIFICATION

When information is needed, always refer to the model number and serial number. Both are located on the top portion of brake cylinder assembly

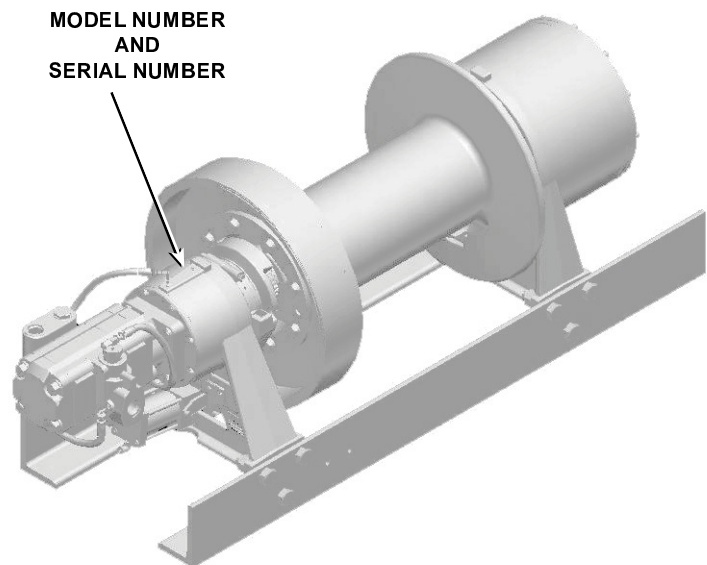

## EXPLANATION OF MODEL NUMBER

**HP 80 A - 123 089/045 - 01 RA**

HP	HYDRAULIC PLANETARY RECOVERY WINCH
80	80,000 POUND (36,335 KG) FIRST-LAYER LINE PULL
A	MODEL SERIES RELATING TO DESIGN CHANGES
123	TOTAL GEAR RATIO (123:1)
089/045	HYDRAULIC MOTOR DISPLACEMENT – 8.92 CU IN. (146.2 CC), 4.46 CU IN. (73.1 CC)/REV
01	DRUM OPTION (VIEWED FROM BEHIND THE TRUCK)
RA	(RIGHT HAND ASSEMBLY) - SIDE OF THE TRUCK BED HYDRAULIC MOTOR IS INSTALLED, W/WIRE ROPE WOUND OVER DRUM

# GENERAL SAFETY RECOMMENDATIONS

Safety for operators and ground personnel is of prime concern. Always take the necessary precautions to ensure the safety of others as well as yourself. To properly ensure safety, the prime mover and winch **MUST** be operated with care and concern by the operator for the equipment. The operator **MUST** also have a thorough knowledge of the machine's performance capabilities.

## **WARNING**

Failure to obey the following safety recommendations may result in property damage, injury, or death.

1. Read and understand **ALL** warning tag information, and become familiar with **ALL** controls **BEFORE** operating the winch.
2. **NEVER** attempt to clean, oil or perform maintenance on a machine with the engine or prime mover running, unless instructed to do so in this manual.
3. **NEVER** operate the winch controls unless you are properly positioned at the operator's station, you are sure **ALL** personnel are clear of the work area **AND** you are properly trained in the operation of the winch.
4. Assure that personnel who are responsible for hand signals are clearly visible and that the signals to be used are thoroughly understood by all involved.
5. Ground personnel should stay in view of the operator and clear of the winch drum. **DO NOT** allow ground personnel near a winch line under tension. A safe distance of at least 1½ times the length of the outstretched cable should be maintained.
6. On machines having hydraulically, mechanically and/or cable controlled equipment or attachments, ensure the equipment is blocked securely before servicing, adjusting or repairing the winch. **ALWAYS** apply the parking brakes before dismounting a vehicle.
7. Inspect the winch and rigging at the beginning of each work shift. Defects should be corrected immediately. **DO NOT** operate a defective winch.
8. Keep equipment in good operating condition. Perform scheduled service and adjustments as defined in the "Preventive Maintenance" section of this manual.
9. An equipment warm-up procedure is recommended for all start-ups, and is essential at ambient temperatures below +40°F (5°C). Refer to the "Warm-Up Procedure" listed in the "Preventive Maintenance" section of this manual.
10. Check the drum clutch to be certain that the negative draft angle is clearly evident on the clutch and clutch plate. **DO NOT** use the winch if the negative draft angles are worn straight, or if the edges of the clutch plate are rounded or chipped.
11. External clutches on recovery winches may disengage and drop or lose control of a load if they are **NOT** fully engaged at the beginning of a lift or pull. The winch operator must **visually** determine that the clutch is **fully** engaged before lifting or pulling a load.
12. The winches described in this manual are neither designed nor intended for use or application to equipment used in the lifting or moving of persons.
13. **DO NOT** exceed the maximum pressure, PSI (kPa), or flow, GPM (LPM), stated in the winch specifications.
14. Operate the winch at line speeds to match the job conditions.
15. Protective gloves should be worn when handling wire rope.
16. **NEVER** attempt to handle wire rope when the hook end is not free. Keep all parts of body and clothing clear of cable rollers, cable entry area of fairleads and winch cable drum.
17. When winding wire rope on the cable drum, **NEVER** attempt to maintain tension by allowing the wire rope to slip through hands. **ALWAYS** use the "Hand-Over-Hand" technique.
18. **NEVER** use wire rope with broken strands. Replace damaged wire rope.
19. **DO NOT** weld on any part of the winch without approval of PACCAR Winch Division Engineering.
20. Use the recommended hydraulic oil and gear lubricant.
21. Keep the hydraulic system clean and free of contamination at all times.
22. Use the correct anchor for the wire rope and pocket in the drum. **DO NOT** use knots to secure or attach the wire rope to the drum or hook.
23. The cable anchor or ferrule is **NOT** intended to support full rated load. **ALWAYS** maintain a minimum of five (5) wraps on the drum. It is recommended the last five (5) wraps of wire rope be painted bright red to serve as a visual reminder.
24. Install guarding to prevent personnel from getting any part of body or clothing caught at a point where the cable is wrapped onto the drum or drawn through guide rollers or other "pinch points".
25. Install switches or valves that will shut off power to the winch, in locations where they can be reached by anyone entangled in the wire rope before being drawn into the winch drum or other "pinch point".
26. "Deadman" controls, which automatically shut off power to the winch whenever the operator leaves his station, should be installed whenever possible.

27. **NEVER** allow anyone to stand or position any part of his or her body under a suspended load.
28. Avoid sudden “shock” loads, or attempting to “jerk” a load free. This type of operation may cause heavy loads, in excess of rated capacity, which may result in a failure of the wire rope and/or the winch.
29. Whenever possible, install the winch in a location that is not immediately adjacent to a “normal” operator’s station.
30. **ALL** winch controls should be located within easy reach of the operator. The controls shall be installed in such a location that the operator is removed from the electrical path to ground if the load, rigging or wire rope comes into contact with or within proximity to an electrically energized conductor.

## THEORY OF OPERATION

### BASIC DESCRIPTION

The winch consists of the following sub-assemblies:

1. Hydraulic motor and brake valve
2. Planetary gear reducer assembly
3. Static brake system
4. Cable drum, drum shaft and clutch
5. Base

The primary sun gear is directly coupled to the hydraulic motor by the inner race of the brake clutch assembly. The primary sun gear shaft goes through the drum and drives the primary planet gears on the support end of the winch. As the motor shaft turns in the haul-in direction, the planetary assemblies reduce the speed input by the motor to rotate the cable drum. In the haul-in direction, the static brake remains fully applied and the input shaft rotates freely through the sprag clutch. When the motor is stopped, the load attempts to rotate the winch gear train in the opposite direction locking the brake clutch to the input shaft, allowing the fully applied static brake to hold the load firm.

### DUAL BRAKE SYSTEM

The dual brake system consists of a dynamic brake system and a static brake system.

The dynamic brake system has two operating components:

1. Brake Valve Assembly
2. Hydraulic Motor

The brake valve is basically a counterbalance valve with better metering characteristics for load control. It contains a check valve to allow free oil flow to the motor in the haul-in direction, and a pilot operated, spring-loaded spool

valve that blocks the flow of oil out of the motor when the control valve is placed in neutral. With the control valve lever moved toward the pay-out direction, the spool valve remains closed until sufficient pilot pressure is applied to the end of the spool to shift it against the spring pressure and open a passage. After the spool valve cracks open, the pilot pressure becomes flow dependent and modulates the spool valve opening, controlling the pay-out speed of the winch. See Figures 1, 2, and 3.

The winch brake system has three main components for all winches:

1. Spring-Applied, Multiple Friction Disc Static Brake
2. Hydraulic Piston and Cylinder
3. Brake Clutch Assembly

The static brake is released by the brake valve pilot pressure at a pressure lower than that required to open the pilot operated spool valve. This sequence ensures that dynamic braking takes place within the brake valve, and that little, if any, heat is absorbed by the static, friction brake. The static friction brake is load holding brake only, and has nothing to do with dynamic braking or the rate of descent of a load.

The brake clutch assembly is splined to the primary sun gear shaft between the hydraulic motor and primary sun gear. It will allow this shaft to turn freely in the direction to haul-in a load, and locks up to force the brake discs to turn with the shaft in the pay-out direction. See Figures 4 and 5.

The hydraulic brake cylinder, when pressurized, will release the spring pressure on the brake discs, allowing the discs to turn freely.

**Figure 1 REELING-IN**

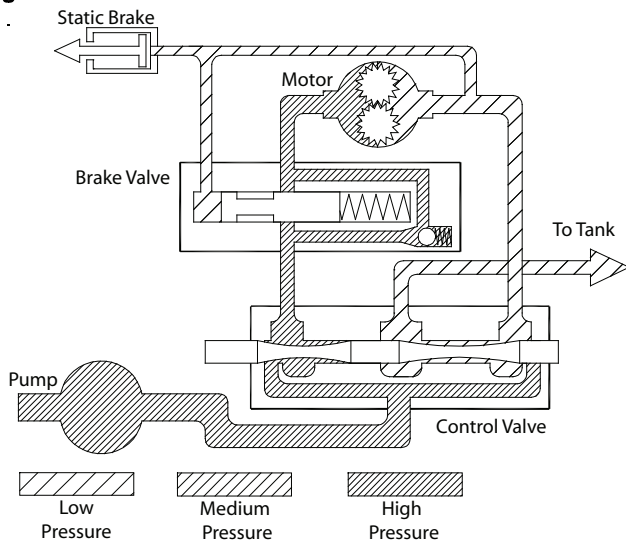

**Figure 4**

Static Friction Brake Applied

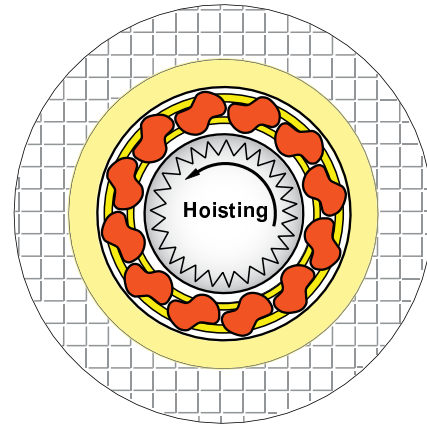

Permits free shaft rotation while hoisting

**Figure 2 REEL-OUT - BEFORE BRAKE VALVE OPENS**

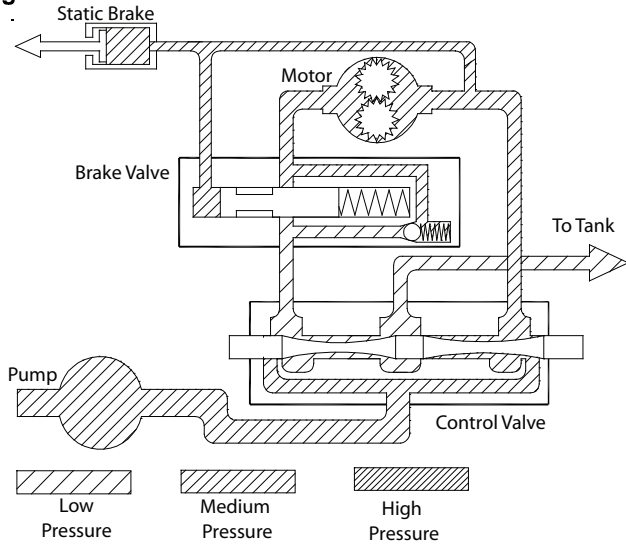

**Figure 5**

Static Friction Brake Applied

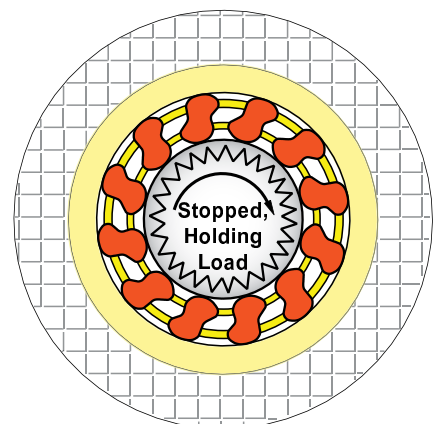

Load attempts to rotate shaft in opposite direction  
Brake clutch locks sun gear shaft to friction brake

**Figure 3 REELING-OUT**

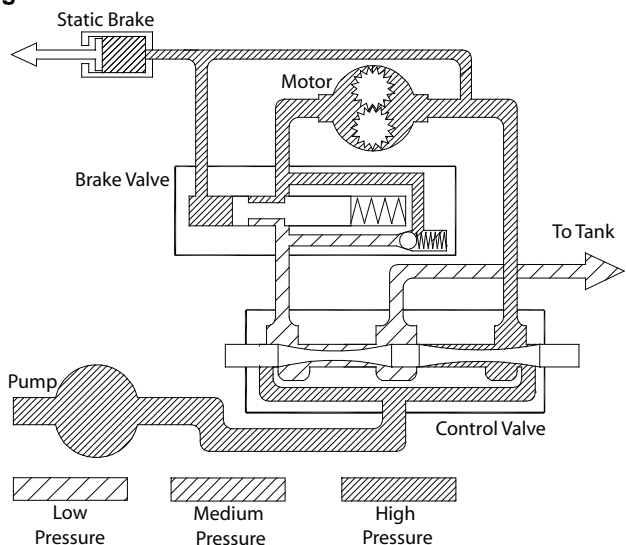

# WINCH INSTALLATION

HP Series winches are configured for bed mount on a truck. A right hand assembly (RA) has the motor end to the passenger side of the vehicle and the wire rope overwound on the drum. A left-hand assembly (LA) has the motor on the driver's side with wire rope overwound on the drum.

Headache racks or other protective structures designed to protect the winch, truck, cab, and vehicle occupants should be designed to enable easy access and servicing of the winch. Braden recommends using a structure designed to be easily removed should the need arise to disassemble the winch for servicing.

1. A tank line for the hydraulic motor case drain is required from the shift block tee fitting on the two-speed motor or from the case drain on the single speed motor. See Step 6 for details.

## ⚠ CAUTION ⚠

Failure to install a case drain line of adequate size will result in a blown out shaft seal on the hydraulic motor and the winch will fill with hydraulic oil.

2. The winch must be mounted to a flat, rigid surface which will not flex under load. The mounting surface must be flat within .020 in. (.05 mm) between mounting fasteners. If necessary, use shim stock to ensure proper mounting.

## ⚠ WARNING ⚠

Flexing or uneven mounting surfaces will produce internal winch distortion which may result in rapid component wear, overheating, poor winch performance or an improperly engaged drum clutch which may become disengaged and result in dropped loads or loss of load control causing property damage, severe injury or death.

3. The centerline of the cable drum must be horizontal and mounted perpendicular to the direction of pull. The fleet angle, or the angle created from an imaginary line from the center of the cable drum to the load or first sheave and from this load point back to the drum barrel intersection with the drum flange, must not exceed 1½°. Fleet angles in excess of 1½° will create uneven spooling resulting in rapid drum or wire rope wear.
4. Grade 8, or better, fasteners are recommended for mounting fasteners.
5. The winch base angles must be mounted securely to the vehicle frame in a manner acceptable to the vehicle manufacturer. Any frame adapter brackets used

should be bolted to the winch base angles as close to the gear housing and bearing leg assemblies as possible. This will ensure the greatest strength while minimizing distortion. Consult vehicle manufacturer before making any modifications to the vehicle frame.

6. Hydraulic lines and components to operate the winch should be of sufficient size as to minimize the backpressure at the hydraulic motor work ports. For conventional gear type motors, backpressure at full flow should NOT exceed 100 PSI (690 kPa) for maximum motor shaft seal life. If high backpressures are encountered, the motor case drain can be connected direct to the reservoir. For backpressures in excess of 100 PSI (690 kPa), contact PACCAR Winch Division Technical Support.

Winches equipped with Rineer 2-speed vane type or piston type motors MUST be limited to 35 PSI (240 kPa) backpressure.

7. The winch directional control valve MUST be a three-position, four-way valve without detents and with a spring-centered motor spool, such that the valve returns to the center (Neutral) position whenever the handle is released, and both work ports are opened to tank (open center, open port).

## ⚠ WARNING ⚠

**DO NOT** use a control valve with any detents or latching mechanism that will hold the control valve in an actuated or running position when the operator releases the control lever. Use of the wrong type of control valve could lead to unintentional operation of the winch, which could result in property damage, injury or death.

8. The hydraulic oil filter should have a 10 micron nominal rating and be a full-flow type.
9. High quality hydraulic oil is essential for satisfactory performance and long hydraulic system component life.

Hydraulic oils having a viscosity of 150 – 300 SUS @ 100°F (30 – 56 cSt @ 40°C) and a viscosity index (VI) of 100 or greater will provide good results under normal temperature condition. The use of oil having a high VI will minimize cold start-up problems and reduce the length of warm-up periods. A high VI will also minimize changes in viscosity with corresponding changes in temperature.

**NOTE:** For MAGNUM series winches equipped with Rineer vane type hydraulic motors, the hydraulic oil selected **MUST** remain above 100 SUS @ 100°F (20 cSt @ 40°C) at all operating temperatures.



Maximum cold weather start-up viscosity should not exceed 5000 SUS with a pour point of at least 20°F (11°C) lower than the minimum expected temperature.

Under continuous operating conditions the temperature of the oil at any point in the system should not exceed 180°F (82°C). 120°-140°F (49°-60°C) is generally considered optimum.

In general terms; for continuous operation at ambient temperatures 50°-110°F (10°-43°C), use SAE 20W; for continuous operation at 10°-90°F (-12°-32°C), use SAE 10W; and for applications at ambient temperatures below 10°F (-12°C), contact the PACCAR Winch Division Product Support Department. NOTE: The use of multi-viscosity oils is generally not recommended.

10. Maximum air pressure of 130 psi for clutch and brake air cylinders.

# TYPICAL HYDRAULIC CIRCUITS

**NOTE:** The hydraulic circuits shown below are representative of typical HP80A winches with single and two-speed hydraulic motors and brake valves. Options and accessory equipment may result in changes to the circuits defined. If there are any questions regarding the hydraulic circuit, refer to the information supplied by the original equipment manufacturer, or contact the PACCAR Winch Division Product Support Department, as previously defined. (ALWAYS have the winch model and serial number available when contacting PACCAR Winch Division.)

## Two Speed

### WINCH CONTROL CIRCUIT EXTERNAL CASE DRAIN REQ'D

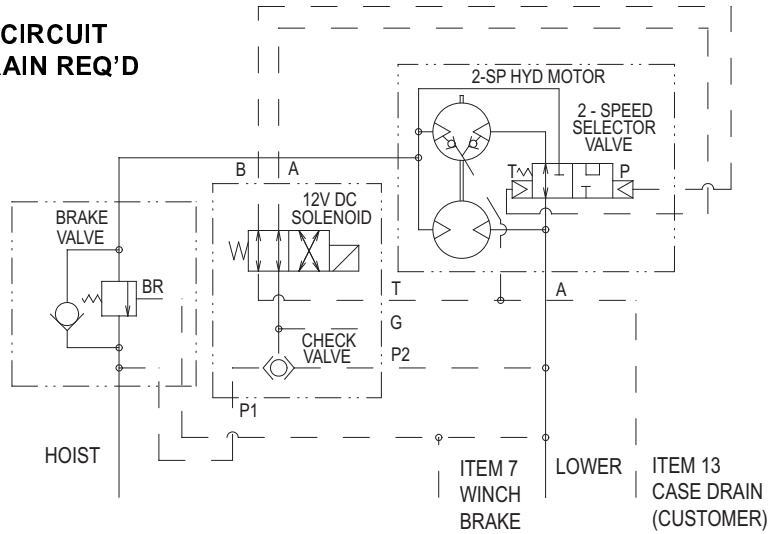

2-Speed Hyd. Motor Sub-Assy Control Circuit  
("A" Port Toward Flange)

## Single Speed

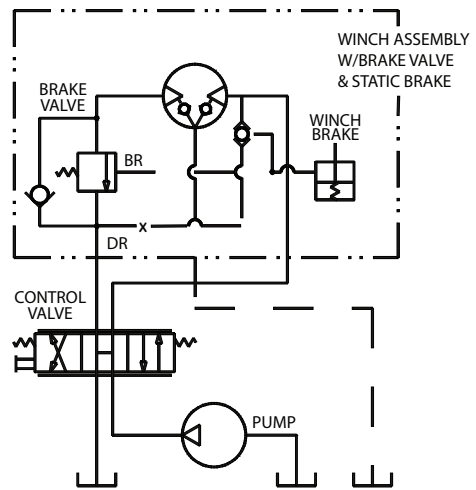

### WINCH CONTROL CIRCUIT EXTERNAL CASE DRAIN REQ'D

### Electric Shift Circuit

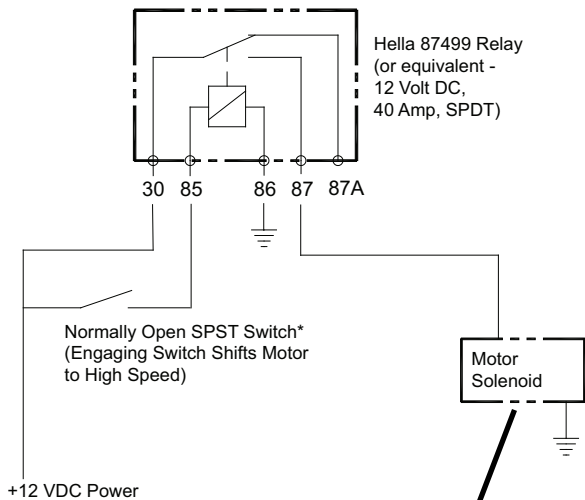

\* DO NOT use a momentary contact switch. This type of switch will return to the open position when released, shifting the motor back to low speed.

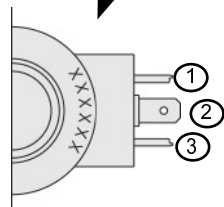

1. Ground
2. Empty
3. Apply 12V DC power to shift motor to High Speed

NOTE:  
Terminals 1 and 3  
may be reversed.

# WIRE ROPE INSTALLATION

Winches are rated at bare drum line pull, meaning the maximum load capability will be reached on the first layer of wire rope. As the cable drum fills, the line pull will decrease (loss of leverage) as the line speed increases (larger circumference). Therefore, it is best to install the minimum length of wire rope possible for your application so the winch will operate on the lowest layers, delivering the maximum load capability.

Use of larger diameter wire rope will not always increase strength as the larger wire rope may be more prone to bending fatigue failure due to the drum diameter. Consult your wire rope supplier for their recommendations regarding the best wire rope and rigging for your application.

## ⚠ WARNING ⚠

Winch wire rope anchors or ferrules are NOT intended to hold rated loads. Winch loads applied directly to the cable anchor may cause the wire rope to pull free and result in sudden loss of load control and cause property damage, injury or death. A minimum of five (5) wraps of wire rope must be left on the drum barrel to achieve rated load.

### INSTALLATION OF U-BOLT TYPE CLAMPS

Prepare the end of the wire rope as recommended by the wire rope manufacturer. Pass the wire rope through the U-bolt until the end extends 1.5 – 2 wire rope diameters beyond the clamp. Evenly tighten the U-bolt nuts until the wire rope deforms slightly under the U-bolt and the wire rope is securely held.

### INSTALLATION OF SPIRAL FERRULES

Re-useable, field installed spiral ferrules are available from PACCAR Winch Division or your wire rope supplier. These ferrules are for use with six (6) strand, IWRC (Independent Wire Rope Core) type wire rope. Refer to cable capacity specifications on page 14.

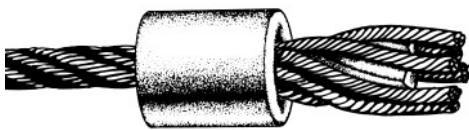

STEP ONE

Insert wire rope through the small diameter end of the ferrule. Spread the strands and insert the spiral wedges between the strands and the core. Lay the strands in the individual grooves in the spiral wedges.

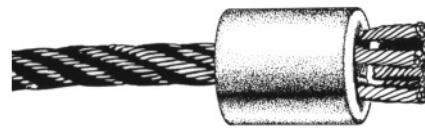

STEP TWO

Tap the wedges and wire rope end into the ferrule, leaving approximately 3/8 in. (10 mm) extending from the top. The first load applied to the winch will seat the wire rope and wedges securely in the ferrule.

# PRE-DELIVERY CHECKLIST

Before releasing the winch to the end user, the following checklist should be reviewed and each item verified.

## INSPECTION

Check gear oil and refill as needed	<input checked="" type="checkbox"/>
Lubricate all grease fittings	<input type="checkbox"/>
Inspect winch mounting fasteners and torque as required	<input type="checkbox"/>
Check for loose or missing bolts, pins, keepers, and cotter pins – replace as needed	<input type="checkbox"/>
Check controls - adjustment and operation	<input type="checkbox"/>
Verify winch operating pressure and flow	<input type="checkbox"/>
Verify proper brake band operation	<input type="checkbox"/>
Inspect for external oil leaks – repair as needed	<input type="checkbox"/>

## WINCH OPERATION

The following warnings and instructions are basic to safe winch operation. Please read them carefully and follow them any time the winch is in use. These instructions are provided in addition to any information provided by the Original Equipment Manufacturer. Equipment operators should be completely familiar with the overall operation of the vehicle to which the winch is installed. If you have any questions concerning the safe operation of this winch or the equipment to which it is mounted, contact the equipment manufacturer that installed the winch, or the PAC-CAR Winch Division Product Support Department, as previously described.

### ⚠ WARNING ⚠

Ground personnel **MUST** stay in view of the operator and clear of the load and cable drum at all times. **DO NOT** allow personnel near the winch line while under tension. **DO NOT** allow personnel near the cable drum during winch operation. **DO NOT** allow personnel to be in line with the load. **DO NOT** allow personnel to stand under a suspended load. A safe distance of 1½ times the working length of the cable should be maintained by ground personnel. A broken wire rope and/or lost load may cause property damage, injury or death.

### ⚠ WARNING ⚠

Failure to properly warm up the winch, particularly under low ambient temperature conditions, may result in temporary brake slippage due to high back pressures attempting to release the brake, which may result in property damage, injury or death.

### ⚠ WARNING ⚠

Failure to use the proper type and viscosity of planetary gear oil may contribute to intermittent brake clutch slippage which could result in property damage, injury or death. Some gear lubricants contain large amounts of EP (extreme pressure) and anti-friction additives which may contribute to brake slippage and damage to brake friction discs or seals. Oil viscosity with regard to ambient temperature is also critical to reliable brake operation. Testing indicates that excessively heavy or thick gear oil may contribute to intermittent brake slippage. Make certain that the gear oil viscosity used in your winch is correct for your prevailing ambient temperature.

The winch directional control valve, described earlier, controls haul-in and pay-out functions of the winch. Moving the control lever in the haul-in direction will cause the winch to pull in the load toward the vehicle. Moving the control lever in the pay-out direction will cause the winch to feed wire rope off the drum.

Two-speed winches are equipped with a two-speed hydraulic motor and solenoid operated shift valve, eliminating the need to add extra valves to allow two-speed operation. A 12V DC toggle switch is required to actuate the solenoid. The motors are spring-biased to low-speed mode. Actuating the toggle switch will energize the solenoid, allowing pilot pressure to act on the shift spool in the motor, shifting the motor to high-speed mode.

## ⚠ WARNING ⚠

When operating the winch in the pay-out direction, **ALWAYS** bring the load to a complete stop **BEFORE** attempting to shift the motor into high speed mode. "Shifting-on-the-fly", or attempting to shift while the load is still moving, will result in pressure intensification between the brake valve and the hydraulic motor, which can damage the motor, brake valve, or other hydraulic components. Failure of these components may cause loss of load control which could lead to personal injury or death.

**NOTE:** *During typical winching operations, it is generally recommended to operate the vehicle engine at high idle RPM and use the winch control valve to control oil flow, and thus winch line speed as needed.*

Position the vehicle such that the centerline of the winch drum is perpendicular to the winch load whenever possible. The wire rope fleet angle must not exceed  $1\frac{1}{2}^\circ$ . If the fleet angle exceeds  $1\frac{1}{2}^\circ$ , the wire rope will not spool correctly eventually resulting in damaged wire rope and prematurely worn winch components.

Either power out the wire rope using the hydraulic system, or disengage the drum clutch and pull the wire rope off the drum by hand (freespool).

## ⚠ WARNING ⚠

The band brake on the clutch end of the cable drum is used to control drum overspin or "birdnesting" **ONLY** when operating in freespool mode with the drum clutch disengaged. **DO NOT** attempt to control any winch load using the band brake. Attempting to control or hold any load with the band brake may result in loss of load, property damage, injury or death.

Securely attach the wire rope to the load in such a manner as to avoid damaging the load or rigging. Fully engage the drum clutch (see Drum Clutch Operation).

Ensure the band brake is released and engage the winch control lever. Operate the winch controls smoothly to avoid "jerking" the load and maintain good load control.

Observe the winch operation carefully to make certain all ground personnel remain clear of the wire rope and load, and that the load does not shift, which may require repositioning the wire rope or the vehicle.

Once the load is positioned properly, move the lever back to neutral to stop the winch. Secure the load as required. Pay out just enough wire rope to remove all tension on the cable drum. Disengage the drum clutch and disconnect the wire rope from the load.

Re-engage the drum clutch. Ensure the drum clutch is fully engaged.

Wind the wire rope onto the cable drum while maintaining the minimum fleet angle and sufficient tension to allow the wire rope to spool properly, being careful to keep hands and clothing away from the cable drum and/or fairlead rollers.

# DRUM CLUTCH OPERATION

Visually ensure that the drum clutch is fully engaged and the clutch control lever is at full travel or locked in its detent **BEFORE** attempting to use the winch under load.

## ⚠ WARNING ⚠

**DO NOT** move the load, the winch, or the winch platform **BEFORE** making certain the drum clutch is set to “ENGAGE” and the clutch is fully engaged. A partially engaged drum clutch may “jump out” of engagement. A load on the winch line may prevent a partially engaged clutch from disengaging, but any change in load condition may allow the clutch to become disengaged unexpectedly. This action may cause a loss of load control which could result in property damage, injury or death.

**NOTE:** Actuation of the drum clutch is typically accomplished using either air cylinder controls or some form of mechanical control (i.e. push-pull cable, mechanical linkages, etc.). Any means used to control the drum clutch must allow full travel of the lever without binding the clutch, or should include locking detents at each position.

### To ENGAGE the drum clutch:

1. Insure the winch motor is stopped and there is no load on the wire rope. The prime mover must be stopped in neutral and the parking brake must be set.
2. Move the clutch control lever fully into the “Engage” position. If the lever will not settle into the fully engaged position, the clutch is not fully engaged. At this point, it may be necessary to MANUALLY rotate the cable drum slightly in either direction to align the clutch lugs, while continuing to hold slight pressure on the control lever. Once the clutch lugs are properly aligned, the clutch should easily engage fully with the clutch plate on the cable drum.

### To DISENGAGE the drum clutch:

1. Insure the winch motor is stopped and there is no load on the wire rope. The prime mover must be stopped in neutral and the parking brake must be set.
2. Move the control lever fully into the “Disengage” position. If the control lever has any resistance to shift, the cable drum may be MANUALLY rotated in the direction to haul-in wire rope to relieve the self-energized load on the clutch lugs and allow the clutch to properly disengage.

## ⚠ WARNING ⚠

**DO NOT** attempt to engage the drum clutch while the cable drum is rotating. **DO NOT** attempt to disengage the drum clutch with a load applied to the wire rope. **DO NOT** use “cheaters” to extend the shift lever length or other means to apply undue force on the lever. Engaging or disengaging the drum clutch while the cable drum is rotating or under load, or the use of undue force, may result in damage to the drum clutch components. Damaged drum clutch components may allow the drum clutch to become disengaged under load, and cause a loss of load control, which could result in property damage, injury or death.

**NOTE:** If your application involves lifting loads and does not require the clutch to be disengaged, it is strongly recommended that the drum clutch be mechanically blocked in the fully engaged position to avoid accidental disengagement of the clutch under load.

## ⚠ WARNING ⚠

Accidental disengagement of the clutch while lifting or lowering may cause a loss of load control, which could lead to property damage, injury or death.

## PROCEDURE FOR DETERMINING THE CONDITION OF CLUTCH LUGS:

There is a “negative draft” angle on the load bearing faces of the clutch and clutch plate to prevent clutch disengagement under load. In addition to visual inspection of the clutch surfaces, the following procedure may be used to ensure that the clutch cannot inadvertently disengage under load:

1. Fully engage the clutch (as previously described).
2. Power approximately 10 ft. (3 m) of wire rope off the drum.
3. Power in very slowly while holding slight pressure on the wire rope to eliminate any slack in the wire rope and the power train. This slight pressure and no-slack condition must be maintained throughout this procedure.

4. Stop the winch with the clutch fully engaged, leaving approximately 3 ft. (1 m) of wire rope extended beyond the drum.
5. Mark one line on or near the tip of the drum flange nearest the gear housing, and a second line on the gear housing adjacent to the first.
6. While maintaining tension on the wire rope, SLOWLY disengage the drum clutch and observe the marked lines. The drum flange should move 1/16 – 5/16 in. (1.5 – 8 mm) in the haul-in direction. If the drum moves LESS than 1/16 in. (1.5 mm), or if the drum rotates in the opposite direction, the winch should be disassembled and the clutch components visually inspected for wear and/or damage and replaced as needed. The drum clutch should be routinely inspected using this procedure.

### WINCH DRUM CLUTCH CONTROL

**⚠ WARNING ⚠**

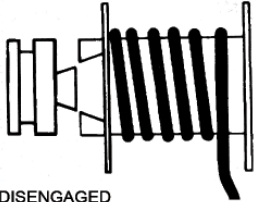

DISENGAGED

- **DO NOT** move the load or the winch platform, or operate the winch before making certain the drum clutch is set to “engage” and the clutch is fully engaged.

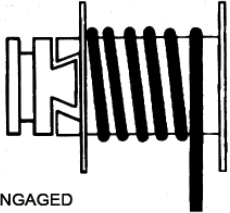

ENGAGED

A load on the winch line may prevent a partially-engaged clutch from disengaging, but any change in the load may allow the clutch to disengage unexpectedly. This could result in loss of load control, property damage, injury, or death.

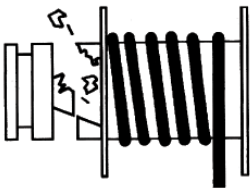

DISENGAGED

- **DO NOT** attempt to engage drum clutch while cable drum is rotating.
- **DO NOT** attempt to disengage drum clutch with a load applied to the winch cable.

Engaging or disengaging the drum clutch while the cable drum is rotating or under load may result in damage to drum clutch components. Damaged drum clutch components may disengage under load, which could result in loss of load control, property damage, injury, or death.

---

Refer to the appropriate BRADEN maintenance publication for more information.

Install this label near winch controls.



PN 100600

The Warning Label shown above is available through all Braden dealers. Have your dealer order part number 100600. It is a self-adhesive weather-resistant vinyl label that we recommend be installed near the winch controls of all Braden winches with a drum clutch.

# AUXILIARY RIGGING

## Snatch Block

An auxiliary sheave, or snatch block, may increase the versatility of the winch, and is highly recommended in the following applications:

- When fleet angles exceed  $1\frac{1}{2}^{\circ}$ .
- When winch loads exceed the safe winch or wire rope capacity.
- When slower line speeds are required for precise load control.

Securely attach the snatch block to the anchor point following the block manufacturer's recommendations.

## Tree Protector

If the wire rope or a snatch block must be anchored to a tree or other structure for recovery purposes, a heavy nylon web sling of proper capacity rating should be used to avoid causing serious damage to the tree.

### ⚠ WARNING ⚠

A poorly attached or undersized snatch block may break loose from the anchor point and cause a sudden loss of load control, which may result in property damage, injury or death.

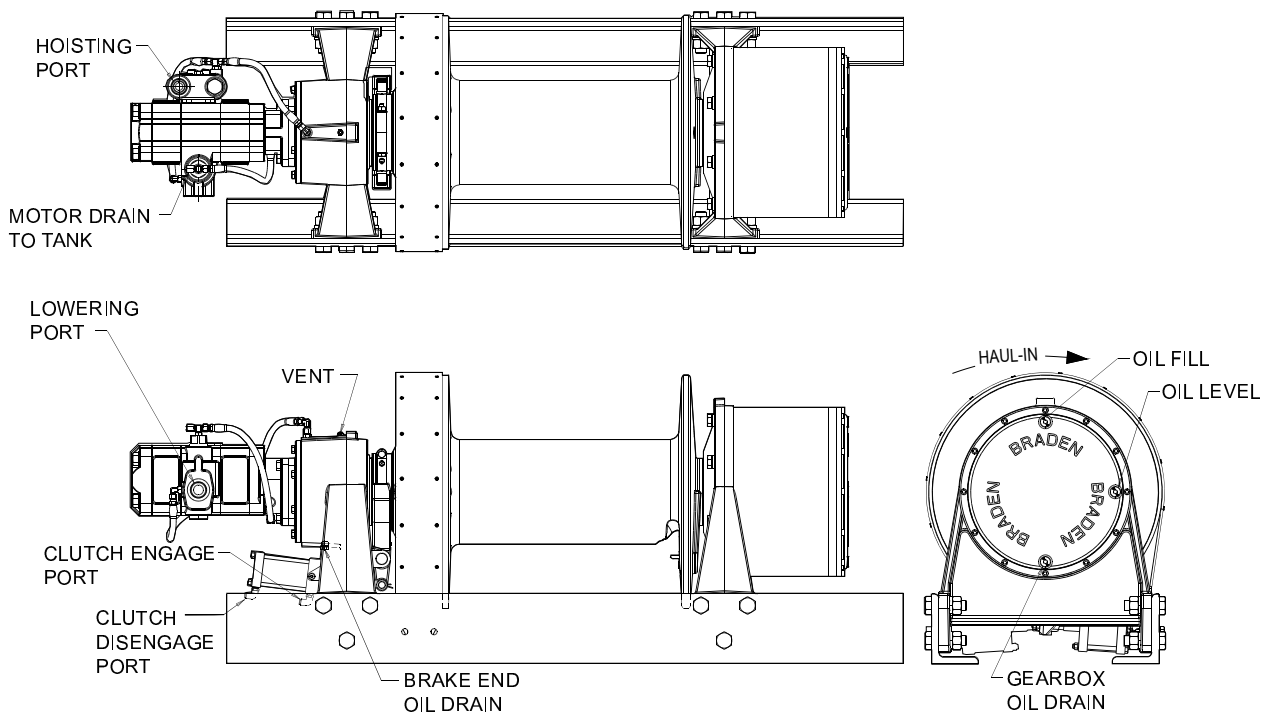

### NOTES:

1. OIL CAPACITY: 12.5 PTS. (7.1 L)  
(ONE PINT TO THE BRAKE END AND 15 PINTS TO THE GEAR END)
2. 1.00 CABLE FERRULE (29427) SUPPLIED WITH WINCH. FERRULES FOR OTHER CABLE SIZES MAY BE PURCHASED SEPARATELY.  
1.13 CABLE FERRULE (29428)
3. MAXIMUM AIR PRESSURE OF 130 PSI (9 BAR) FOR CLUTCH AND BRAKE CYLINDER.



# PREVENTIVE MAINTENANCE

A regular program of preventive maintenance for your winch is required to minimize the need for emergency servicing and will promote safe, reliable winch operation.

The user of PACCAR Winch products is responsible for winch inspection, testing, operator training and the maintenance noted below, with frequency dependent on the severity of the winch duty cycle and the thoroughness of the preventive maintenance program.

Field experience, supported by engineering testing, indicate the two service procedures listed below are the most critical to safe, reliable winch operation and **MUST** be observed.

- Regular Gear Oil Changes
- Use of Proper Gear Oil – recommended type for prevailing ambient temperatures and additives.

## ⚠ WARNING ⚠

**NEVER** attempt to service a winch with the prime mover running as accidental engagement may result in property damage, injury or death. Make certain **ALL** load is removed from the wire rope and winch cable drum **BEFORE** servicing the winch. A loaded wire rope may rapidly and unexpectedly unspool, resulting in property damage, injury or death.

### Recommended Preventive Maintenance Intervals:

#### Daily (when winch is in use)

1. Inspect the wire rope and rigging for broken wires or other damage, as recommended by the wire rope and rigging manufacturer(s).
2. Carefully inspect the drum clutch and adjust the shift mechanism as required to ensure the clutch can be fully engaged and disengaged. (Refer to “Drum Clutch Operation”).
3. Check for external oil leaks – both hydraulic and gear oil – and repair as required. This is extremely important due to the accelerated wear that can be caused by insufficient lubrication within the winch. Gear oil must be maintained at the proper level. Use only recommended lubricants. (See “Recommended Lubricants” in this manual.)
4. Check hydraulic motor plumbing for damage, such as chafed or deteriorating hoses, and repair as needed.
5. Visually inspect for loose or missing bolts, pins, keepers or cotter pins, and tighten or replace as needed.

#### Weekly

1. Perform all daily inspections.
2. Check gear oil level, and refill as needed with the recommended lubricant.
3. Lubricate the grease fittings on the bearing leg, cable

drum ends and clutch. On some winches, you will have to disengage the clutch to gain access to the drum bushing grease fitting on the clutch end of the drum. Use a high-quality, moly-type grease, with a rating of NLGI-2 or better.

4. Inspect the gear housing breather to ensure the fitting is not clogged with dirt or grease. Clean or replace as needed.
5. Inspect all winch mounting fasteners. Retighten or replace as required.
6. Inspect any structural welds, and repair as needed.

#### Monthly

1. Perform all daily and weekly inspections.
2. Inspect the drum clutch and clutch plate to ensure the negative draft angle is clearly evident. Replace worn clutch components as required. (Refer to “Drum Clutch Operation” in this manual.)

## ⚠ WARNING ⚠

**DO NOT** use the winch if the negative draft angle on the clutch is not present or is worn straight, or if the clutch plate edges are rounded or chipped. A defective drum clutch may suddenly become disengaged causing a loss of load control, which may result in property damage, injury or death.

3. Check the hydraulic system relief valve setting to ensure proper performance and protection of hydraulic components. Adjust or repair as required.
4. Inspect hydraulic system filters and strainers. Follow the system manufacturer’s service recommendations for repair or replacement.
5. Inspect the band brake for wear or chipping away of the brake lining material. Adjust or replace as needed.

#### Yearly

1. Perform all daily, weekly and monthly inspections.
2. Replace gear oil.

**NOTE:** If the winch is used in excess of 40 hours per week, the gear oil should be changed every 6 months.

## ⚠ WARNING ⚠

Hot oil can cause severe injury. Make certain the oil has cooled to a safe temperature before servicing.

Inspection Performed	Inspection Interval			
	Daily	Weekly	Monthly	Yearly
Inspect wire rope and rigging	X	X	X	X
Inspect drum clutch and shift mechanism for proper engagement	X	X	X	X
Inspect for external oil leaks	X	X	X	X
Check for damaged hoses / lines	X	X	X	X
Check for loose or missing bolts, pins, keepers, or cotter pins	X	X	X	X
Check gear oil level / refill		X	X	X
Lubricate grease fittings		X	X	X
Inspect breather fitting		X	X	X
Inspect winch mounting fasteners - torque as required		X	X	X
Inspect structural welds		X	X	X
Inspect negative draft angle on drum clutch and clutch plate			X	X
Check hydraulic relief valve setting			X	X
Inspect hydraulic filters / strainers			X	X
Inspect band brake			X	X
Replace gear oil <sup>(1)(2)</sup>				X

**NOTES:**

- (1) Change the gear oil after the first 100 hours or 30 days of use, whichever occurs first.
- (2) For winch operation in excess of 40 hours per week, oil changes should occur every 6 months instead of yearly.

## SPECIFICATIONS

HP80A-123089/045-01

STANDARD		123:1 RATIO					
Motor Code		089 (Low Speed)		045 (High Speed)			
Displacement		8.92 cu in.		4.46 cu in.			
Pressure		2671 psi		2674 psi			
Flow		60 gpm					
Rope Dia. (in.)	Layer	Line Pull (lb)	Line Speed (fpm)	Line Pull (lb)	Line Speed (fpm)	Rope Capacity (ft)	
	1.0	1	80000	27	38270	60	47
		2	66670	32	31890	72	103
		3	57140	38	27330	84	168
		4	50000	43	23920	96	243
		5	44450	49	21260	108	327

METRIC		123:1 RATIO					
Motor Code		089 (Low Speed)		045 (High Speed)			
Displacement		146.2 cc		73.1 cc			
Pressure		184 bar					
Flow		227 lpm					
Rope Dia. (mm)	Layer	Line Pull (kg)	Line Speed (Mpm)	Line Pull (kg)	Line Speed (Mpm)	Rope Capacity (M)	
	25	1	36335	8	17395	18	14
		2	30305	10	14495	22	31
		3	25975	11	12425	26	51
		4	22725	13	10875	29	74
		5	20205	15	9665	33	100

## RECOMMENDED PLANETARY GEAR OIL

Field experience, supported by engineering endurance tests, indicates the use of the proper gear oil and a program of regular preventive maintenance will help provide extended gear train life and reliable winch brake performance. For this reason, BRADEN has published the following specifications to assist in determining which lubricant is best suited to your application.

### ⚠ WARNING ⚠

Failure to use the proper type and viscosity of planetary gear oil may contribute to intermittent brake clutch slippage which could result in property damage, severe personal injury or death. Some gear lubricants contain large amounts of EP (extreme pressure) and anti-friction additives which may contribute to brake clutch slippage or damage to brake friction discs or seals. Oil viscosity with regard to ambient temperature is also critical to reliable brake clutch operation. Our tests indicate that excessively heavy or thick gear oil may contribute to intermittent brake clutch slippage. Make certain that the gear oil viscosity used in your winch is correct for your prevailing ambient temperature.

For simplicity, BRADEN has listed available products in each temperature range that have been tested and found to meet our specifications. This is not to say that other lubricant brands would not perform equally as well.

If the following lubricant brands are not available in your area, make certain your lubricant vendor supplies you with oil that is equivalent to those products listed below.

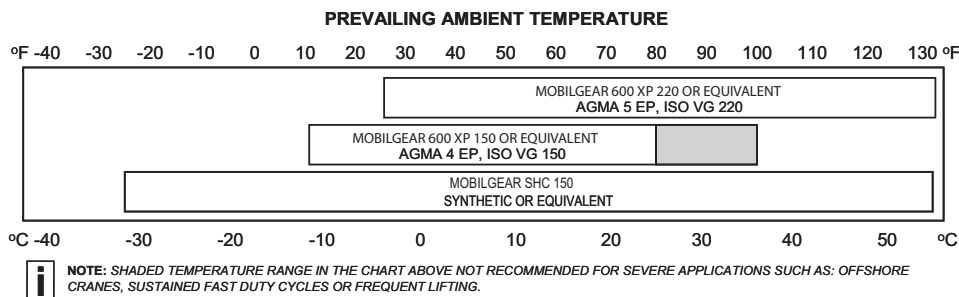

Planetary hoists are factory filled with Mobilgear 600 XP 150, or equivalent. Consult your oil supplier for other equivalent oils if required.

Mobil	Shell	Chevron	Texaco
Mobilgear 600 XP 150	Omala 150	Gear Compounds EP 150	Meropa 150
Mobilgear 600 XP 220	Omala 220	Gear Compounds EP 220	Meropa 220

Unless otherwise specified, it is recommended that the gear oil be changed after the first one hundred (100) hours or thirty (30) days of machine operation, then every one thousand (1,000) hours or twelve (12) months, whichever occurs first. The gear oil should also be changed whenever the ambient temperature changes significantly and an oil from a different temperature range would be more appropriate.

A warm-up procedure is recommended at each start-up and is essential at ambient temperatures below +40°F (4°C).

The prime mover should be run at its lowest recommended RPM with the hydraulic winch control valve in neutral allowing sufficient time to warm up the system. The winch should then be operated at low speeds, forward and reverse, several times to prime all lines with warm hydraulic oil and to circulate gear lubricant through the planetary gear sets.

### ⚠ WARNING ⚠

Failure to properly warm up the winch, particularly under low ambient temperature conditions, may result in temporary brake slippage due to high back pressures attempting to release the brake, which could result in property damage, severe personal injury or death.

If you have any questions regarding this bulletin or your BRADEN planetary winch, please contact the BRADEN Product Support Department at 1-918-251-8511, Monday through Friday from 08:00 to 16:30 hours CST, or by fax at 1-918-259-1575.

# TROUBLESHOOTING

TROUBLE	PROBABLE CAUSE	REMEDY
<p style="text-align: center;"><b>A</b></p> <p>The winch will not reel-out the load or not reel-out the load smoothly.</p>	<ol style="list-style-type: none"> <li>1. The problem could be a plugged or loose pilot orifice. The pilot orifice is a small pipe plug with a hole drilled through it, located behind the pilot port fitting on the brake valve. If it becomes plugged, it will prevent the pilot pressure, from the manifold, from opening the brake valve. If it becomes loose, it will allow an unregulated amount of oil in to operate the brake valve which causes erratic brake valve operation.</li> <li>2. The friction brake may not be releasing as a result of a defective brake cylinder seal.</li> </ol> <p><b>NOTE:</b> <i>If the brake cylinder seal is defective you will usually find oil leaking from the winch vent plug.</i></p> <ol style="list-style-type: none"> <li>3. Friction brake will not release as a result of damaged brake discs.</li> </ol>	<p>Remove the pilot hose and fitting from the brake valve, then use a 5/32 inch Allen wrench to remove the pilot orifice. The diameter of the orifice is approximately .020 inches. Clean and install the pilot orifice tightly in the brake valve.</p> <p>Check brake cylinder seal as follows:</p> <p>A. Disconnect the swivel tee from the brake release port. Connect a hand pump with accurate 0-2000 psi gauge and shut-off valve to the -4 J.I.C. fitting in the brake release port.</p> <p>B. Apply 1000 psi to the brake. Close shut-off valve and let stand for five (5) minutes.</p> <p>C. If there is any loss of pressure in five (5) minutes, the brake cylinder should be disassembled for inspection of the sealing surfaces and replacement of the seals. Refer to "Motor Support-Brake Cylinder Service".</p> <p>Disassemble brake to inspect brake discs. Check stack-up height as described in "Motor Support-Brake Cylinder Service".</p>
<p style="text-align: center;"><b>B</b></p> <p>Oil leaks from vent plug.</p>	<ol style="list-style-type: none"> <li>1. Same as A2.</li> <li>2. Motor seal may be defective as a result of high system back pressure or contaminated oil.</li> </ol>	<p>Same as A2.</p> <p>System back pressure must not exceed 125 psi. Inspect hydraulic system for a restriction in the return line from the control valve to the reservoir. Be sure control valve and plumbing is properly sized to winch motor. Ensure case drain line is connected and adequate size.</p> <p>Oil analysis may indicate contamination has worn motor shaft and seal. Thoroughly flush entire hydraulic system and install new filters and oil. Install new motor seal.</p>

TROUBLE	PROBABLE CAUSE	REMEDY
<p style="text-align: center;"><b>C</b></p> <p>The brake will not hold a load with the control lever in neutral.</p>	<ol style="list-style-type: none"> <li>1. Excessive system back pressure acting on the brake release port.</li> <li>2. Friction brake will not hold due to worn or damaged brake discs.</li> <li>3. Brake clutch is slipping.</li> </ol>	<p>The same as Remedy 2 of Trouble B2.</p> <p>Same as Remedy 3 of Trouble A3.</p> <p>Improper planetary gear oil may cause the brake clutch to slip. Drain old gear oil and flush winch with solvent. Thoroughly drain solvent and refill winch with recommended planetary gear oil listed in "Preventive Maintenance".</p> <p>Brake clutch may be damaged or worn. Disassemble and inspect brake clutch as described in "Brake Clutch Service".</p>
<p style="text-align: center;"><b>D</b></p> <p>The winch will not reel-in the rated load.</p>	<ol style="list-style-type: none"> <li>1. The winch may be mounted on an uneven or flexible surface which causes distortion of the winch base and binding of the gear train. Binding in the gear train will absorb horsepower needed to hoist the rated load and cause heat.</li> <li>2. System relief valve may be set too low. Relief valve needs adjustment or repair</li> <li>3. Be certain hydraulic system temperature is not more than 180 degrees F. Excessive hydraulic oil temperatures increase motor internal leakage and reduce motor performance.</li> <li>4. Winch line pull rating is based on 1st layer of wire rope.</li> <li>5. Rigging and sheaves not operating efficiently.</li> </ol>	<p>Reinforce mounting surface.</p> <p>If necessary, use shim stock to level winch. Refer to "Winch Installation".</p> <p>First loosen, then evenly retighten all winch mounting bolts to recommended torque.</p> <p>Check relief pressure as follows:</p> <p>A. Install an accurate 0-4000 psi (27,580 kPa) gauge into the inlet port of the brake valve.</p> <p>B. Apply a stall pull load on the winch while monitoring pressure.</p> <p>C. Compare gauge reading to winch specifications. Adjust relief valve as required.</p> <p><b>NOTE:</b> <i>If pressure does not increase in proportion to adjustment, relief valve may be contaminated or worn out. In either case, the relief valve may require disassembly or replacement.</i></p> <p>Refer to winch performance charts for additional information.</p> <p>Perform rigging service as recommended by crane manufacturer.</p>

<b>TROUBLE</b>	<b>PROBABLE CAUSE</b>	<b>REMEDY</b>
<p style="text-align: center;"><b>E</b></p> <p>The winch runs hot.</p>	<ol style="list-style-type: none"> <li>1. Same as D1.</li> <li>2. Be certain that the hydraulic system temperature is not more than 180 degrees F. Excessive hydraulic oil temperatures may be caused by:               <ol style="list-style-type: none"> <li>A. Plugged heat exchanger.</li> <li>B. Too low or too high oil level in hydraulic reservoir.</li> <li>C. Same as D2.</li> <li>D. Hydraulic pump not operating efficiently.</li> </ol> </li> <li>3. Excessively worn or damaged internal winch parts.</li> </ol>	<p>Same as remedies for Trouble D1.</p> <p>Thoroughly clean exterior and flush interior.</p> <p>Fill/drain to proper level.</p> <p>Same as remedies for Trouble D2.</p> <p>Prime mover low on horsepower or R.P.M. Tune/adjust prime mover.</p> <p>Check suction line for damage.</p> <p>If pump is belt driven, belts are slipping. Replace/tighten belts.</p> <p>Pump worn. Replace pump.</p> <p>Disassemble winch to inspect/replace worn parts.</p>
<p style="text-align: center;"><b>F</b></p> <p>Winch "chatters" while raising rated load.</p>	<ol style="list-style-type: none"> <li>1. Same as D2.</li> <li>2. Hydraulic oil flow to motor may be too low.</li> <li>3. Controls being operated too quickly.</li> </ol>	<p>Same as remedies for Trouble D2.</p> <p>Same as remedies for Trouble E2.</p> <p>Conduct operator training as required.</p>

# SERVICE PRECAUTIONS

Before any part is removed from the hoist or drive gearbox, all service instructions should be read and understood.

Work in a clean, dust free area as cleanliness is of utmost importance when servicing hydraulic equipment.

Inspect all replacement parts, prior to installation, to detect any damage which might have occurred in shipment.

Use only genuine BRADEN replacement parts for optimum results. Never re-use expendable parts such as o-rings and oil seals.

Inspect all machined surfaces for excessive wear or damage before reassembly operations are begun.

Lubricate all o-rings and oil seals with gear oil prior to installation.

Lubricate all bearings with oil soluble grease prior to assembly.

Use a sealing compound on the outside surface of oil seals and a light coat of thread sealing compound on pipe threads. Avoid getting sealing compound inside parts or passages which conduct oil.

Before starting disassembly of the winch, remove the wire rope, drain the oil and clean the outside surfaces to avoid contaminating gears and bearings.

# RECOMMENDED BOLT TORQUE

The general purpose torque shown in the chart applies to SAE Grade 5 & Grade 8 bolts, studs and standard steel full, thick and high nuts.

Higher or lower torques for special applications will be specified such as the use of spanner nuts, nuts on shaft ends, jam nuts and where distortion of parts or gaskets is critical.

Lubricated torque values based on use of SAE 30 engine oil applied to threads and face of bolt or nut.

Bolt Diam. Inches	Thread per inch	Torque LB-FT (N.m)			
		Grade 5		Grade 8	
		Dry	Lubed	Dry	Lubed
1/4	20	8	6	12	9
	28	(11)	(8)	(16)	(12)
5/16	18	17	13	24	18
	24	(23)	(17)	(33)	(24)
3/8	16	31	23	45	35
	24	(42)	(31)	(61)	(47)
7/16	14	50	35	70	50
	20	(68)	(47)	(95)	(68)
1/2	13	75	55	110	80
	20	(102)	(75)	(149)	(108)
9/16	12	110	80	150	110
	18	(149)	(108)	(203)	(149)
5/8	11	150	115	210	160
	18	(203)	(156)	(285)	(217)

Bolt Diam. Inches	Thread per inch	Torque LB-FT (N.m)			
		Grade 5		Grade 8	
		Dry	Lubed	Dry	Lubed
3/4	10	265	200	380	280
	16	(359)	(271)	(515)	(380)
7/8	9	420	325	600	450
	14	(569)	(441)	(813)	(610)
1	8	640	485	910	680
	14	(868)	(658)	(1234)	(922)
1 1/8	7	790	590	1290	970
	12	(1071)	(800)	(1749)	(1315)
1 1/4	7	1120	835	1820	1360
	12	(1518)	(1132)	(2468)	(1817)
1 3/8	6	1460	1095	2385	1790
	12	(1979)	(1485)	(3234)	(2427)
1 1/2	6	1940	1460	3160	2370
	12	(2360)	(1979)	(4284)	(3214)

To convert LB-FT to Kg-m, multiply LB-FT value by 0.1383

8-2008

# WINCH DISASSEMBLY

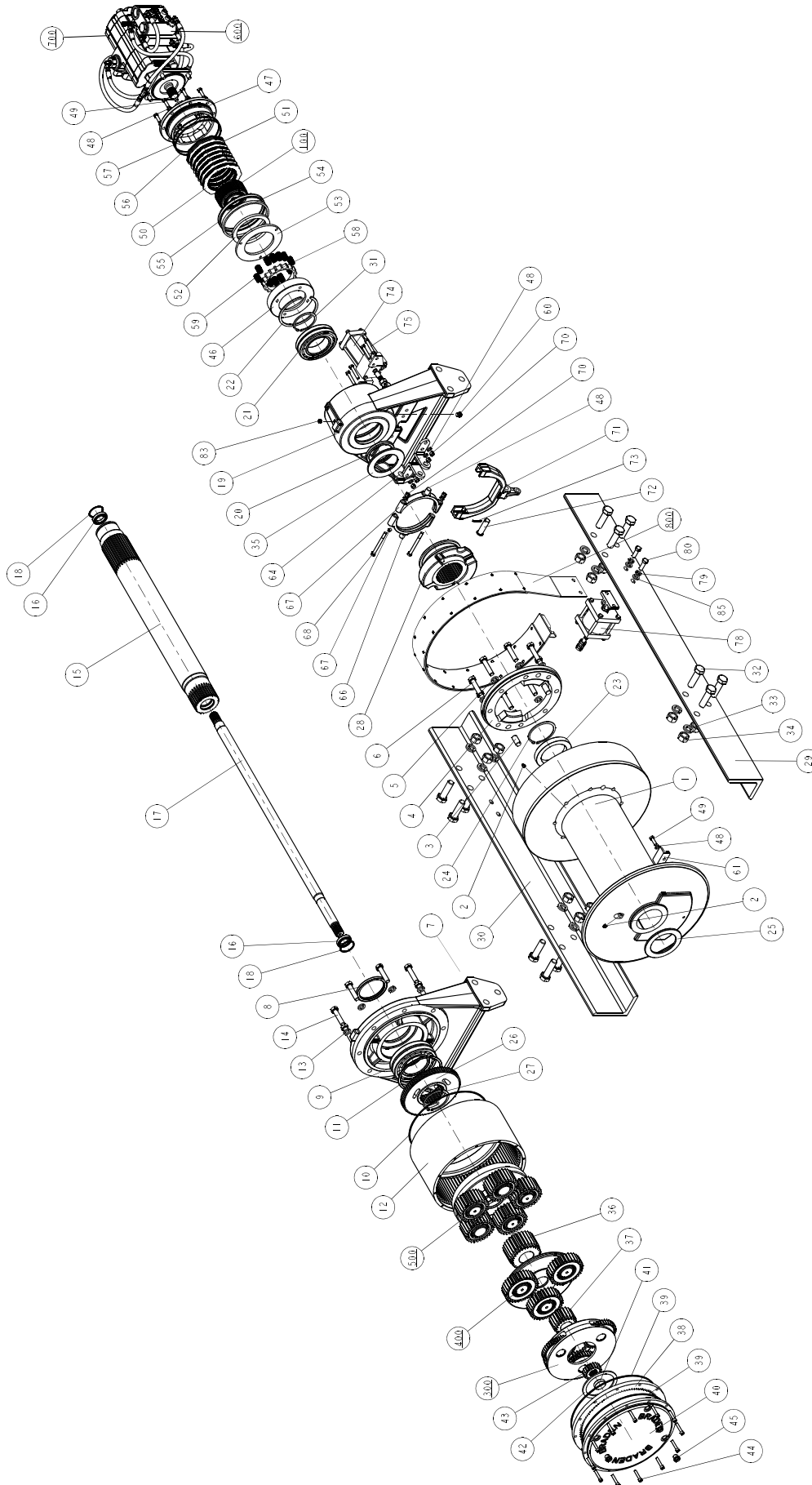



ITEM	DESCRIPTION	QTY	ITEM	DESCRIPTION	QTY	ITEM	DESCRIPTION	QTY
1	DRUM, CABLE	1	33	LOCKWASHER	12	67	GREASE FITTING	1
2	GREASE FITTING	2	34	NUT-HEAVY	12	68	CAPSCREW (3/8 - 16 X 4-1/4 GD8Z)	2
3	CLUTCH PLATE DOWEL PIN	2	35	SPACER, DRUM	1	70	NUT	6
4	CLUTCH PLATE	1	36	GEAR, OUTPUT SUN	1	71	FORK, SHIFTER	1
5	LOCKWASHER (5/8 Z)	8	37	GEAR, SECONDARY SUN	1	72	PIVOT PIN, CLUTCH SHIFT FORK	1
6	CAPSCREW (5/8 - 18 X 2-3/4 GD8Z)	8	38	GEAR, RING	1	73	COTTER PIN	1
7	END BRACKET	1	39	O-RING	2	74	KIT, AIR CLUTCH	1
8	SEAL, LIP	1	40	COVER	1	75	CAPSCREW (3/8 - 16 X 2-1/4 GD8Z)	4
9	BEARING, SPHERICAL ROLLER	1	41	THRUST BUTTON	1	78	KIT, AIR BRAKE	1
10	O-RING	1	42	WASHER, THRUST	1	79	LOCKWASHER (1/2 Z)	2
11	RING, INTERNAL RETAINING	1	43	GEAR, PRIMARY SUN	1	80	CAPSCREW (1/2 - 13 X 1-1/2 GD8Z)	2
12	GEAR, RING	1	44	CAPSCREW - METRIC M8-1.25 X 45 GD12.9 Z	12	81	NAMEPLATE, GH5, PD5 WINCHES	1
13	LOCKWASHER (5/8 z)	8	45	PLUG, METRIC	3	82	DRIVE SCREW	4
14	CAPSCREW (5/8 - 11 X 2-3/4 GD8Z)	8	46	STOP, SPRING	1	83	RELIEF VALVE 7.5-15 PSI	1
15	SHAFT, CABLE DRUM	1	47	ADAPTER, MOTOR	1	84	FERRULE	1
16	BEARING, BALL	2	48	LOCKWASHER (3/8 Z)	15	100	OVERRUNNING CLUTCH ASSY-C SHFT	1
17	SHAFT, PRIMARY SUN/DRIVE	1	49	CAPSCREW (3/8 - 16 X 1-1/4 GD8 Z)	9	300	PRIMARY PLANET CARRIER SUB-ASSY	1
18	RING, INTERNAL RETAINING	2	50	BRAKE DISC	11	400	SECONDARY PLANET CARRIER SUB-ASSY	1
19	BRACKET, MOTOR END	1	51	FRICTION DISC	6	500	FINAL PLANET CARRIER SUB-ASSY	1
20	SEAL, LIP	1	52	BRAKE PLATE SPACER	1	600	BRAKE VALVE ASSEMBLY	1
21	BEARING, SPHERICAL ROLLER	1	53	PRESSURE PLATE	1	700	HYD MOTOR GROUP	1
22	RING, INTERNAL RETAINING	1	54	PISTON BACKUP RING	1	800	BRAKE BAND ASSEMBLY	1
23	SPACER, DRUM CLUTCH	1	55	SEAL, U-CUP	1			
24	RETAINING RING	1	56	O-RING	1			
25	SPACER, DRUM	1	57	BACK-UP WASHER	1			
26	ADAPTER, OUTPUT	1	58	SPRING SPACER	1			
27	RETAINING RING	1	59	BRAKE SPRING	12			
28	CLUTCH, SLIDING	1	60	PLUG, O-RING BOSS-HEX HD	1			
29	BASE ANGLE	1	61	PLATE, ANCHOR RETAINER	1			
30	BASE ANGLE	1	64	BRACKET, SHIFT FORK	2			
31	RING, EXTERNAL RETAINING	1	65	CLUTCH RIDER	1			
32	CAPSCREW (7/8 - 9 X 3 GD8Z)	12	66	CLUTCH RIDER	1			

## DISASSEMBLY

### ⚠ WARNING ⚠

The HP80A winch weighs approximately 1,470 lbs (667 kg). Ensure all lifting equipment including the overhead hoist and rigging have adequate capacity. Use of lifting equipment that does not have adequate lifting capacity may result in personal injury or death.

1. Remove the wire rope from the winch and drain the gear oil from the winch by removing the drain plug on the bottom of the winch gearbox. Remove the fill/vent plug to speed draining.
2. Take precautions to collect hydraulic oil and remove the hydraulic hoses connected to the winch motor and disconnect the brake release hose from the winch brake release port. Ensure there are no external hose connections to the winch motor then remove the motor by removing the four capscrews securing it to the winch.
3. Remove the overrunning clutch assembly (100) from the brake cylinder assembly.

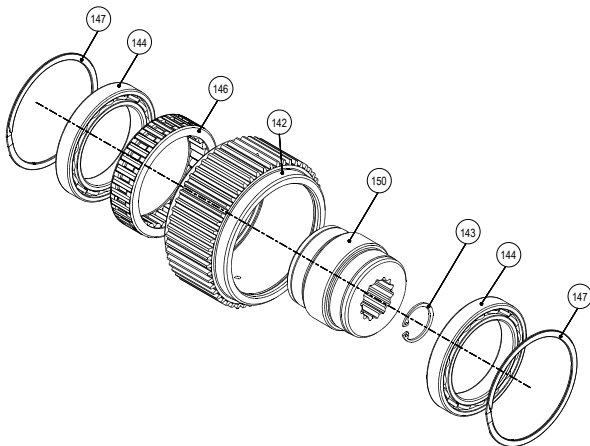

ITEM	DESCRIPTION	QTY
100	OVERRUNNING CLUTCH	1
142	OUTER RACE	1
143	RETAINING RING	1
144	BALL BEARING	2
146	CLUTCH	1
147	RETAINING RING	2
150	INNER RACE	1

\*NSS = Not Serviced Separately

Order entire overrunning clutch assembly

4. Remove motor adapter (47) from the end bracket (19). Remove the steel brake plates, friction discs, and brake plate spacer.
5. On the gearbox end of the winch, remove the cover (40) by removing the capscrews (44). Remove the thrust button (41) and thrust washer (42).

### ⚠ WARNING ⚠

The Primary Planet Carrier Assembly weighs approximately 29 lbs (13 kg). Ensure all lifting equipment including the overhead hoist and rigging have adequate capacity. Use of lifting equipment that does not have adequate lifting capacity or is not properly maintained may result in personal injury or death.

### ⚠ WARNING ⚠

The Secondary Planet Carrier Assembly weighs approximately 35 lbs (16 kg). Ensure all lifting equipment including the overhead hoist and rigging have adequate capacity. Use of lifting equipment that does not have adequate lifting capacity or is not properly maintained may result in personal injury or death.

6. Remove the primary planet carrier assembly (300) and primary sun gear (43).

### ⚠ WARNING ⚠

The Output Planet Carrier Assembly weighs approximately 69 lbs (32 kg). Ensure all lifting equipment including the overhead hoist and rigging have adequate capacity. Use of lifting equipment that does not have adequate lifting capacity or is not properly maintained may result in personal injury or death.

7. Remove the secondary planet carrier assembly (400) and secondary sun gear (37).
8. Remove the output planet carrier assembly (500) and output sun gear (36).

### ⚠ WARNING ⚠

The Drum weighs approximately 417 lbs (189 kg). Ensure all lifting equipment including the overhead hoist and rigging have adequate capacity. Use of lifting equipment that does not have adequate lifting capacity or is not properly maintained may result in personal injury or death.

9. Support the ring gear (12) with an overhead hoist. Remove bolts (14) and remove the ring gear.

**⚠ WARNING ⚠**

The Ring Gear weighs approximately 73 lbs (33 kg). Ensure all lifting equipment including the overhead hoist and rigging have adequate capacity. Use of lifting equipment that does not have adequate lifting capacity or is not properly maintained may result in personal injury or death.

10. Remove snap ring (27) and adapter (26).
11. Block the drum in position or support the drum with an overhead hoist in preparation for removing it.

**⚠ WARNING ⚠**

The End Bracket weighs approximately 103 lbs (47 kg). Ensure all lifting equipment including the overhead hoist and rigging have adequate capacity. Use of lifting equipment that does not have adequate lifting capacity or is not properly maintained may result in personal injury or death.

12. Support the end bracket (7) with an overhead hoist. Remove the bolts (32) securing the end bracket to the base angles (29) and (30.) Slide the end bracket away from the drum shaft and remove the drum spacer (25.)

**⚠ WARNING ⚠**

The Drum weighs approximately 417 lbs (189 kg). Ensure all lifting equipment including the overhead hoist and rigging have adequate capacity. Use of lifting equipment that does not have adequate lifting capacity or is not properly maintained may result in personal injury or death.

13. Slide the drum (1) off the shaft and remove the drum spacer (35).
14. Remove the retaining ring (31) from the drum shaft. Slide the drum shaft out of the end bracket (7).
15. Remove the sliding clutch (28), clutch plate (4), and clutch fork (71) from the drum shaft (15).

# HP80A TOP LEVEL ASSEMBLY

Before beginning this top level assembly, the overrunning clutch assembly and planetary gear set assemblies should be assembled following the instructions in this manual.

## ⚠ WARNING ⚠

The HP80A winch weighs approximately 1470 lbs (667 kg). Ensure all lifting equipment including the overhead hoist and rigging have adequate capacity. Use of lifting equipment that does not have adequate lifting capacity or is not properly maintained may result in personal injury or death.

1. Apply Loctite Aviation Gasket Sealant to the outside diameter of the seal (20) and install into end bracket (19).
2. Lightly lubricate inside of seal (20) with grease.
3. Flip end bracket (19) over. Coat **bearing carrier** with a light coat of grease. Install bearing (21) and retaining ring (22). Install spring stop (46) and spring spacer (58).
4. Install 12 brake springs (59) in 4 groups of 3 springs spaced evenly around the spring spacer (58).
5. Install pressure plate (53).
6. Install brake plate spacer (52).
7. Install piston back up ring (54) and seal (55). Apply a light coat of grease to aid in assembly.  
**NOTE:** *Lubricate the friction discs in hydraulic oil prior to assembly.*
8. Set motor adapter (47) on workbench with motor mounting surface down. Install back-up washer (57) and o-ring (56). Apply a light coat of grease to aid in assembly.
9. Insert first 5 steel brake discs (50) followed by a friction disc (51) and then alternate steel discs (50) and friction discs (51) ending with a steel disc (50) on top.
10. Apply hydraulic oil or petroleum jelly to the entire sealing surface of the motor adapter and piston seal. Install the motor adapter in the end bracket (19) being careful to avoid damaging the piston seal. Ensure the brake plate spacer (52) remains in position.
11. Install lock washers (48) on the hex-head capscrews (49). Install the capscrews and tighten 1 turn each in a crisscross pattern to evenly draw the motor adapter down onto the brake support. Torque the capscrews in a crisscross pattern.
12. Install plug (60) into the lower end bracket motor brake housing.
13. Install air clutch kit (74) on motor end of end bracket (19) using supplied brackets and capscrews (75), lock washers (48), and nuts (70). Install shifter fork (71) using shift fork pivot pin (72) and cotter pin (73).
14. Apply Loctite Aviation Gasket Sealant to the outside diameter of the seal (8) and install into end bracket (7).
15. Lightly lubricate inside of seal (8) with grease.
16. Flip end bracket (7) over. Coat **bearing carrier** with a light coat of grease. Install bearing (9) and retaining ring (11).
17. Apply a light coat of grease to large o-ring (10) and install.

## ⚠ WARNING ⚠

The Ring Gear weighs approximately 73 lbs (33 kg). Ensure all lifting equipment including the overhead hoist and rigging have adequate capacity. Use of lifting equipment that does not have adequate lifting capacity or is not properly maintained may result in personal injury or death.

18. To install ring gear (12), set end bracket (7) slightly over the edge of workbench to start 2 capscrews (14) and lock washers (13) in ring gear.
19. Carefully set end bracket (7) on its side to install the rest of the capscrews and lock washers.
20. Set cable drum outer shaft (15) upright on the floor. Ensure shaft does not fall.
21. Use an overhead hoist to lift the end bracket and ring gear assembly and set it down on top edge of cable drum shaft (15).
22. Install adapter (26) and retaining ring (27) and the outer shaft (15).
23. Install bearing (16) and retaining ring (18) inside the end of cable drum shaft (15).

## ⚠ WARNING ⚠

The Output Planet Carrier Assembly weighs approximately 69 lbs (32 kg). Ensure all lifting equipment including the overhead hoist and rigging have adequate capacity. Use of lifting equipment that does not have adequate lifting capacity or is not properly maintained may result in personal injury or death.

24. Use the tapped holes (3/8 -16 UNC) in the post of the output planetary carrier assembly (500) to lift the output planet carrier assembly and install into the ring gear housing. Ensure the output carrier is fully engaged on adapter (26) and install output sun gear (36).

### ⚠ WARNING ⚠

The Secondary Planet Carrier Assembly weights approximately 35 lbs (16 kg). Ensure all lifting equipment including the overhead hoist and rigging have adequate capacity. Use of lifting equipment that does not have adequate lifting capacity or is not properly maintained may result in personal injury or death.

25. Use the tapped holes in the secondary planet carrier assembly (400) and install the secondary planet carrier into the ring gear. Ensure the secondary carrier is fully seated on the output sun gear (36). Install the secondary sun gear (37).

### ⚠ WARNING ⚠

The Primary Planet Carrier Assembly weights approximately 29 lbs (13 kg). Ensure all lifting equipment including the overhead hoist and rigging have adequate capacity. Use of lifting equipment that does not have adequate lifting capacity or is not properly maintained may result in personal injury or death.

26. Install the primary planet carrier assembly (300) into the ring gear and ensure it is fully engaged with the splines on the secondary sun gear (37). Install primary sun gear (43).

27. Lightly grease large o-ring (39) and install. Install ring gear (38).

28. Lightly grease large o-ring (39) and install on cover (40). Install generous amount of grease to thrust button (41). Carefully install the cover (40) with O-ring (39), thrust washer (42), and thrust button (41). Apply Loctite 242 to 12 cover capscrews (Metric M8 X 1.25 GD12.9 Z) (Item 44) and torque to 25 ft – lbs (34 Nm).

29. Install 3 metric plugs (45).

30. Set base angles (29) and (30) on workbench.

31. Use an overhead hoist to lift the end bracket and ring gear assembly. Install the end bracket in the base angles (29) and (30) and hand tighten capscrews (32) lock washers (33) and nuts (34).

32. **Rotate assembly to where the shaft points to you.**

33. Install inner shaft (17), ensuring it is fully engaged. Install bearing (16) and retaining ring (18).

34. Install drum spacer (25) on cable drum shaft (15).

35. Install grease fittings (2) in the drum.

### ⚠ WARNING ⚠

The Drum weighs approximately 417 lbs (189 kg). Ensure all lifting equipment including the overhead hoist and rigging have adequate capacity. Use of lifting equipment that does not have adequate lifting capacity or is not properly maintained may result in personal injury or death.

36. Use an overhead hoist to install cable drum (1) on shaft.

37. Install anchor retaining plate (61), lockwasher (48), and capscrew (49).

38. Lubricate drum bushings using a grease gun at grease zerk (2).

39. Install drums spacer (23) and retaining ring (24).

40. Install clutch plate (4) on drum (1) using capscrews (6) and lockwashers (5). Torque bolts item (6) to 185 ft/lbs.

41. Install dowel pins (3).

42. Lightly grease to outer shaft (15) and install sliding clutch (28).

43. Secure the 2 halves of the clutch rider (66) to the clutch (28) using bolts (68), lockwashers (48), and nuts (70). Install grease fitting (67).

44. Install drum spacer (35).

45. Install air clutch kit (74) using shift fork bracket (64), capscrews (75) lockwashers (48), and nuts (70).

46. Install brake band assembly (800) over drum and attach to base angle (29) and air brake piston (78) using capscrews (80), lockwashers (79) and washers (85).

47. Attached piston rod to clamping end of brake with supplied nuts.

48. Install piston of air clutch kit (74) to end bracket (19) using capscrews (75) lockwashers (48) and nuts (70). Install shifter fork (71) to piston rod using shift fork pivot pin (72) and cotter pin (73).

49. Use an overhead hoist to lift the motor end bracket assembly. Install the end bracket in the base angles (29) and (30) and hand tighten capscrews (32) lock washers (33) and nuts (34).

50. Install overrunning clutch (100) into the brake cylinder engaging the brake clutch inner race splines. Ensure proper orientation after installation by turning the brake clutch inner race in the CLOCKWISE direction before installing the motor. The drum should turn in the reel in direction.
51. Install the o-ring on the hydraulic motor pilot and lubricate slightly with hydraulic oil. Install the hydraulic motor subassembly on the winch.
52. Torque fasteners connecting the end brackets (7) and (19) to the base angles (29) and (30).
53. Add the recommended gear oil to the winch gearbox and the winch brake. The gear end takes 15 pints of oil and the brake end takes 1 pint.

# PRIMARY PLANET CARRIER SERVICE

## DISASSEMBLY

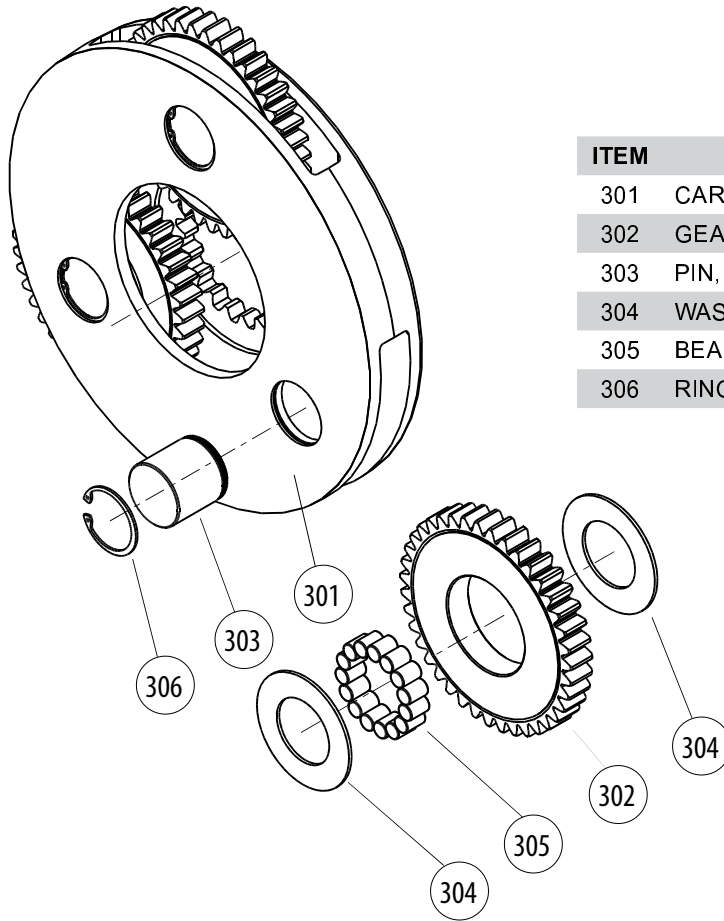

ITEM	DESCRIPTION	QTY
301	CARRIER, PRIMARY PLANET	1
302	GEAR, PRIMARY PLANET	3
303	PIN, PRIMARY PLANET	3
304	WASHER, THRUST	6
305	BEARING, ROLLER	45
306	RING, RETAINING INTERNAL	3

1. Remove the retaining ring (306) from one of the planet carrier gears.

3. Repeat the above steps for the remaining two planet gears.

### **⚠ WARNING ⚠**

Observe safety procedures when operating a hydraulic press. Failure to follow safety procedures can result in personal injury or death.

### **⚠ CAUTION ⚠**

If the planet carrier is not properly supported or excessive force is applied to the planet pin, damage to the planet carrier can occur.

2. Use a press to drive the planet pin (303) knurl past the carrier. Place a tray or bucket under the press to catch any loose bearing rollers (305) that drop. If the planet pin (303) is supported after it clears the knurl surface, the bearing rollers will remain in place. Hold both thrust washers (304) against the gear (302) while sliding the planet pin (303) out of the gear then pull the gear from the carrier keeping the thrust washers against the gear.

4. Thoroughly clean all parts and inspect for damage and wear. The bearing rollers should exhibit no irregularities. If the rollers show any sign of spalling, corrosion, discoloration, material displacement or abnormal wear, the bearing rollers should be replaced. The thrust washer contact areas should be free from any surface irregularities that may cause abrasion or friction. The planet gears (302) and planet pins (303) should be inspected for abnormal wear or pitting.

# PRIMARY PLANET CARRIER SERVICE

## ASSEMBLY

The loose roller bearings can be difficult to keep in place during assembly. This procedure is written to ease the assembly of the planet carriers.

1. Clean and inspect parts as described in step 4 of the disassembly procedure.
2. Place planet gear (302) on clean workbench resting on the gear teeth. Coat bearing rollers (9) with grease and place in lower half of gear. Coat one thrust washer (304) with grease and place in position on planet gear. Slide planet pin (303) into planet gear and center. Grease remaining bearing rollers (305) and slide between planet gear (302) and planet pin (303). After all bearing rollers are in gear, grease remaining thrust washer (304) and slide over planet pin into position on gear to hold roller bearings in place.
3. Place planet carrier (301) on work bench with planet pin retaining ring groove facing up.
4. Hold planet pin in position with the thrust washers (304) against gear and lift gear so the planet pin is vertical. While holding washers in place, slide planet pin out of gear. Slide planet gear with washers into planet carrier (301) and align with the carrier opening. Slide planet pin - **knurled end first** - through planet carrier and gear until knurl seats against opposite side of the planet carrier.

5. Place planet carrier in hydraulic press and provide support around planet pin hole. Slowly press the knurled surface of the planet pin into carrier until retaining ring groove is visible. Install retaining ring (306).

### **WARNING**

Observe safety procedures when operating a hydraulic press. Failure to follow safety procedures can result in personal injury or death.

### **CAUTION**

If the planet carrier is not properly supported or excessive force is applied to the planet pin, damage to the planet carrier can occur.

6. Repeat procedure for remaining two planet gears.



# SECONDARY PLANET CARRIER SERVICE

## DISASSEMBLY

ITEM	DESCRIPTION	QTY
401	SECONDARY PLANET CARRIER	1
402	SECONDARY PLANET GEAR	3
403	SNAP RING	3
404	BEARING	3
405	SPACER	6
406	RETAINING RING	6
407	SPACER	1

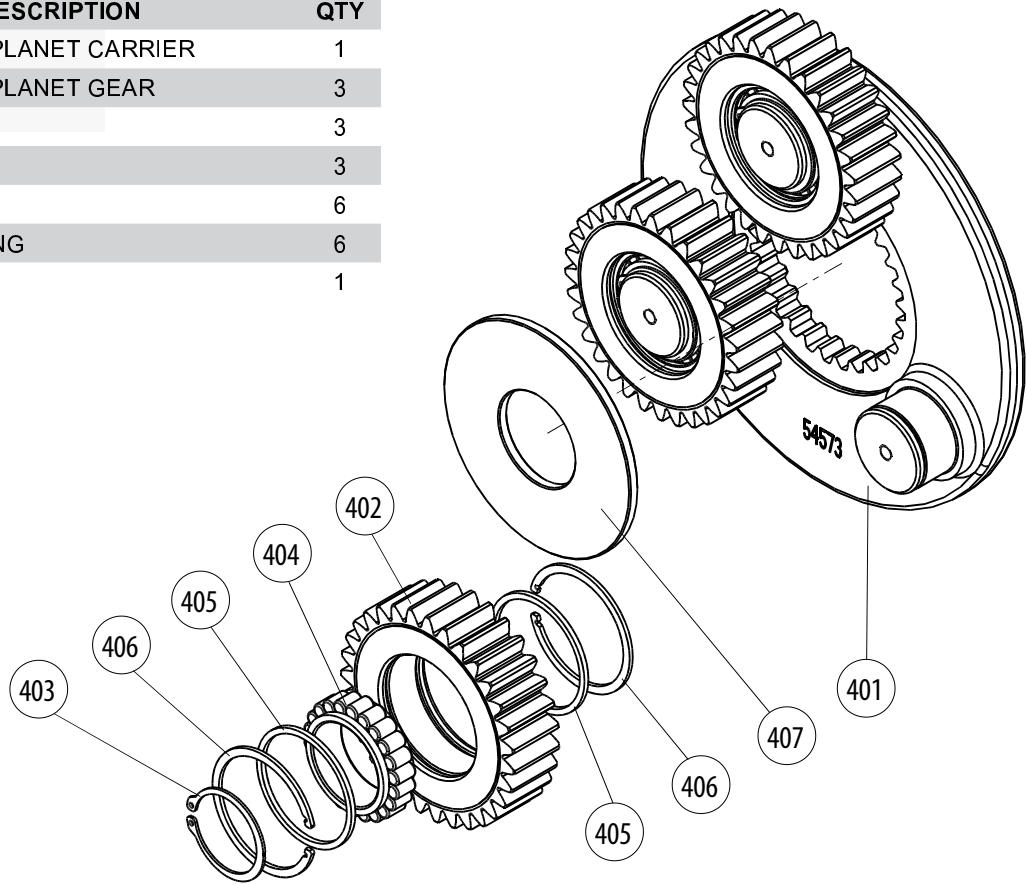

1. Remove the snap ring (403) from one of the planet carrier posts.
2. Use a gear puller to pull the planet gear (402) off of the planet carrier post. If a gear puller is not available, two pry-bars positioned 180° apart can be used to pry the gear off of the planet carrier post, but care must be taken to ensure the pry-bar does not contact and damage the planet carrier post machined surface.
3. The loose rollers will scatter if dropped so take precautions to ensure they are captured during this step of disassembly. Remove the retaining ring (406) and spacer (405) and push the roller bearing out of the gear (402).
4. Repeat the above steps for the remaining two planet gears.
5. Thoroughly clean all parts and inspect for damage and wear. The bearing rollers and bearing race should exhibit no irregularities. If the rollers or race show any signs of spalling, corrosion, discoloration, material displacement or abnormal wear, the bearing rollers should be replaced. The thrust washer contact areas should be free from any surface irregularities that may cause abrasion or friction. The gears and planet pins should be inspected for abnormal wear or pitting.

## ASSEMBLY

The loose roller bearings can be difficult to keep in place during assembly. This procedure attempts to simplify this.

1. Clean and inspect parts as described in step 4 of the disassembly procedure.
2. Place planet gear (402) on clean workbench. Install a spacer (405) and retaining ring (406) in one side of the planet gear. Set the bearing inner race near the planet gear and coat bearing rollers (404) with enough NLGI #2 grease to hold the bearing rollers in place on the inner race. A rubber band can be used to hold the bearing rollers on the inner race if needed; slide it off once the rollers enter the gear. Slide the bearing into the planet gear.
3. Install the remaining spacer (405) and then install remaining retaining ring (406) in gear.
4. Ensure the spacer (70) is in place in the planet carrier before installing gears on the planet carrier posts.
5. Apply a light coat of grease the planet carrier bearing post and then slide the planet gear onto the planet carrier post.
6. Install the snap-ring (403) to secure the planet gear to the planet carrier.
7. Repeat procedure for remaining two planet gears.

# OUTPUT PLANET CARRIER SERVICE

## DISASSEMBLY

## ASSEMBLY

ITEM	DESCRIPTION	QTY
501	OUTPUT PLANET CARRIER	1
502	OUTPUT PLANET GEAR	5
503	SNAP RING	5
504	BEARING, CYLINDRICAL ROLLER	10
505	SPACER, THRUST	10
506	RETAINING RING, INT	5
507	SPACER, THRUST	1

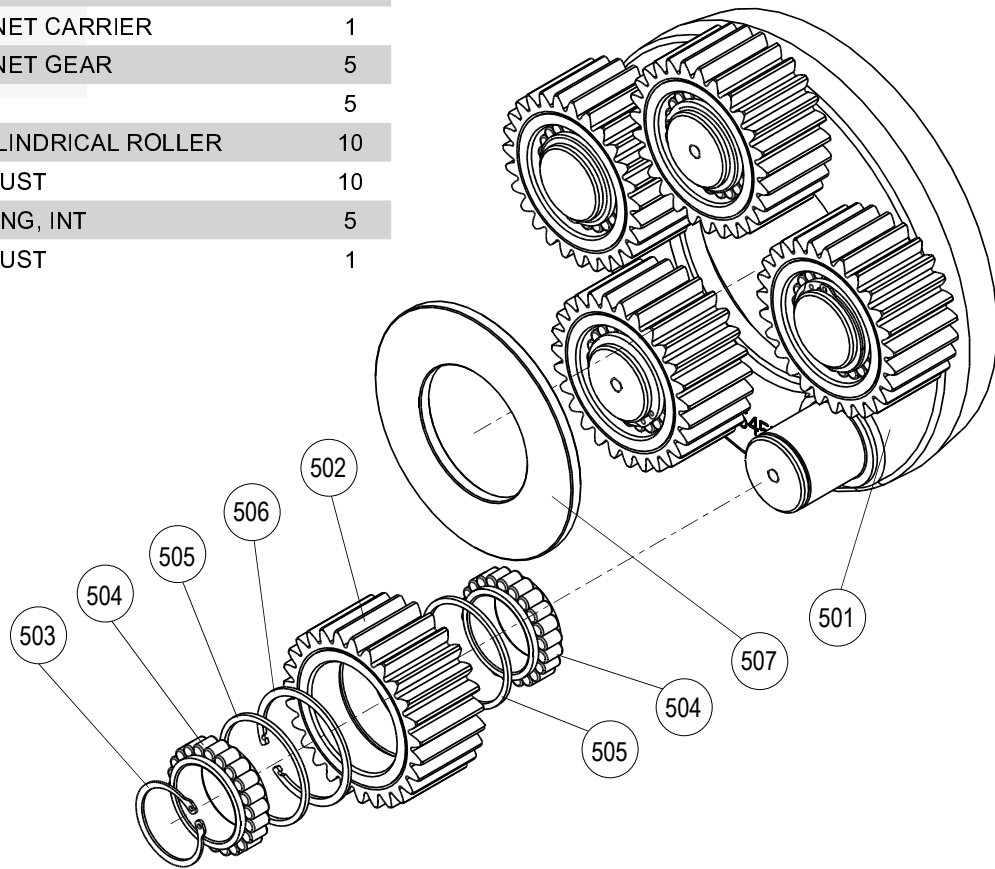

1. Remove the retaining ring (503) from one of the planet carrier posts.
2. The loose rollers will scatter if dropped so take precautions to ensure they are captured during this step of disassembly. Use a gear puller to pull the planet gear (502) off of the planet carrier post. If a gear puller is not available, two pry-bars positioned 180° apart can be used to pry the gear off of the planet carrier post, but care must be taken to ensure the pry-bar does not contact and damage the planet carrier post.
3. Push the roller bearings out of the gear (502) and remove the retaining ring (506) and two thrust washers (505).
4. Repeat the above steps for the remaining planet gears.
5. Thoroughly clean all parts and inspect for damage and wear. The bearing rollers and bearing race should exhibit no irregularities. If the rollers or race show any signs of spalling, corrosion, discoloration, material displacement or abnormal wear, the bearing rollers should be replaced. The thrust washer contact areas should be free from any surface irregularities that may cause abrasion or friction. The gears and planet pins should be inspected for abnormal wear or pitting.

## ASSEMBLY

The loose roller bearings can be difficult to keep in place during assembly. This procedure attempts to simplify this.

1. Clean and inspect parts as described in step 4 of the disassembly procedure.
2. Ensure spacer (506) is installed in the planet carrier (501) before installing the gears on the planet carrier posts.
3. Place planet gear (502) on clean workbench. Install retaining ring (506) in the center groove of planet gear and place one of the thrust washers (505) on the retaining ring.
4. Set the bearing inner race near the planet gear and coat bearing rollers (504) with enough grease to hold the bearing rollers in place on the inner race. A rubber band can be used to hold the bearing rollers on the inner race if needed; slide it off once the rollers enter the gear. Slide the bearing into the planet gear. Hold the rollers in place and turn the planet gear over. Set remaining thrust washer (505) on top of retaining ring (506) and repeat this assembly step for the second bearing set for this planet gear.
5. Apply a light coat of grease the planet carrier bearing post and then slide the planet gear onto the planet carrier post.
6. Install the snap-ring (503) to secure the planet gear to the planet carrier.
7. Repeat procedure for remaining planet gears.

# OVERRUNNING CLUTCH SERVICE

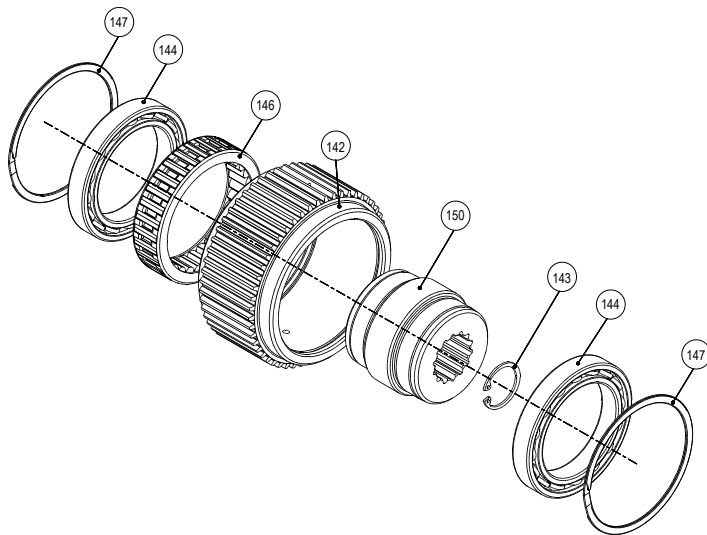

ITEM	DESCRIPTION	QTY
142	OUTER RACE	1
143	RETAINING RING	1
144	BALL BEARING	2
146	OVERRUNNING CLUTCH	1
147	RETAINING RING	2
150	INNER RACE	1

**NOTE:** Outer race (item 142), Inner race (item 150) and Overrunning clutch (item 146) are NOT SOLD individually as replacement parts. If any of these parts require replacement, the entire overrunning clutch assembly must be replaced. Carefully note the relative orientation between the inner and outer races, and the direction of free rotation of the inner race. The clutch **MUST** be re-assembled correctly for proper hoist operation.

## ⚠ WARNING ⚠

The polished surfaces of the inner and outer race and the overrunning cams must be perfectly smooth to insure positive engagement of the clutch. The slightest defect may reduce clutch effectiveness, which may lead to loss of load control and result in property damage, injury or death. It is generally recommended to replace the entire clutch assembly if any component is defective. For these reasons, the overrunning clutch assembly should be disassembled for inspection only if the hoist has exhibited any unusual operation that would point toward a clutch malfunction, or the overrunning clutch assembly shows external signs of mechanical damage.

## DISASSEMBLY

1. Remove one of the retaining rings (item 147) from the outer race (item 142). Push the inner race (item 150), bearings (item 144) and overrunning clutch (item 146) through the outer race.
2. Use a small punch and hammer to tap one of the bearings (item 144) off of the inner race. The overrunning clutch can now be removed from the inner race. Closely inspect the overrunning clutch and the polished surfaces of the inner and outer race for wear, cracks, pitting, corrosion or mechanical damage. Closely inspect the bearings for any signs of damage, wear, corrosion, pitting or heat discoloration.

## ASSEMBLY

### ⚠ WARNING ⚠

Failure to assemble the overrunning clutch assembly with all parts oriented correctly may result in reduced brake effectiveness, which may lead to loss of load control and result in property damage, injury or death.

1. If both bearings (item 144) have been removed from the inner race, install one of them now.
2. Install the overrunning clutch onto the inner race. Rotate the inner race slightly to get the clutch started onto the inner race.
3. Install the other bearing onto the inner race.
4. The outer race should have one retaining ring (item 147) installed in one end. Carefully slide the inner race, with bearings and clutch, into the outer race. Install the other retaining ring into the outer race.

### 14 TOOTH INTERNAL SPLINE

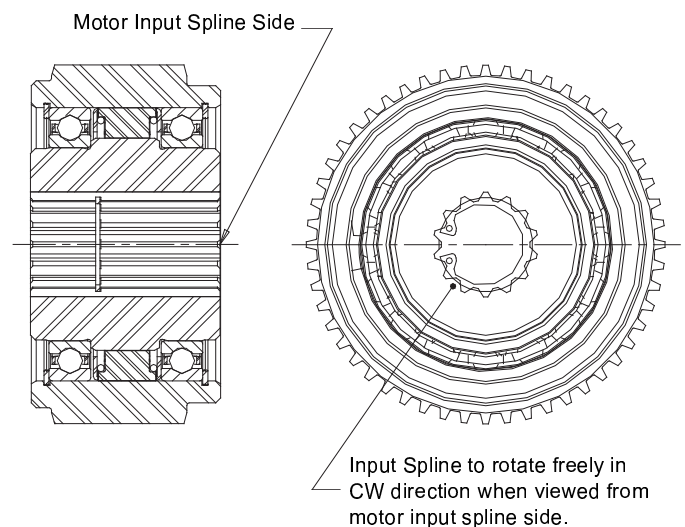

# HP80A ROTATION CHANGE

This winch as shipped from the factory is configured for installation with the motor on the driver side of the truck bed and the cable reeling-in over the drum as shown below.

Configuration on standard winch from the factory.

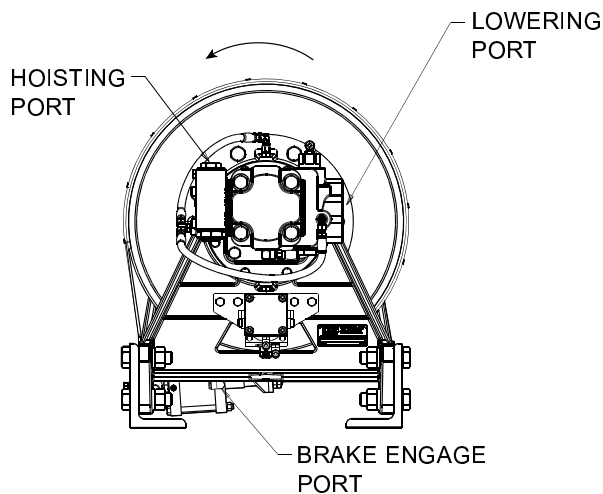

2. For the Rineer two-speed motor and Commercial single speed motor, the brake valve and shift-block must be moved to the opposite side motor split flange port. And the plumbing changed so the lowering signal to the brake and brake valve comes from the opposite side as originally plumbed.
3. The overrunning clutch assembly must be taken apart and the sprag (100) flipped. After reassembly, the inner race should free turn in the clockwise direction viewed from the motor side. See overrunning clutch service section in this manual.

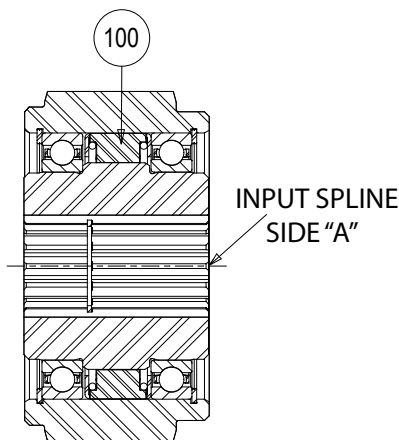

If the winch must be mounted with the motor on the passenger side and the winch reels-in over the drum, then the following changes must be made for proper operation:

1. For the Commercial two-speed motor ONLY: This procedure should be done by a Parker/Commercial dealer so that the hydraulic motor retains its warranty. The motor must be taken apart and the center section (dotted lines) rotated to get the brake valve on the opposite side. Normally, the brake valve would simply be bolted to the opposite flange, but since this two speed motor has a -16 ORB port on the reel-out side the complete center section must be rotated.

Free rotation is changed to clockwise viewed from side "A" (motor side) when motor is mounted on driver's side and rope winds over drum.

4. Band brake must be reversed.

**NOTE:** Motor must be broken-in in the new rotation by gradually pulling increased loads to rated load.

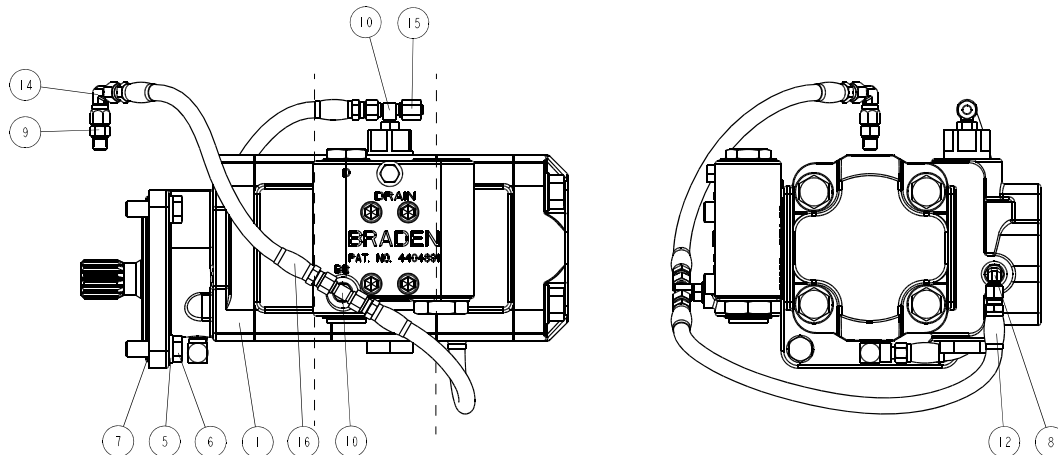

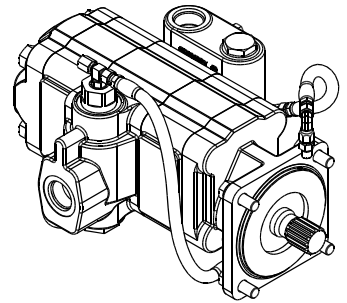
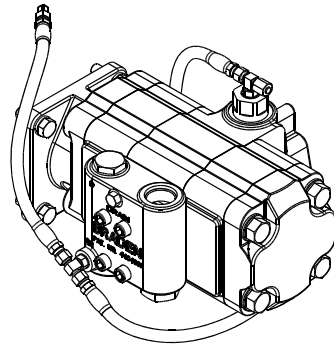
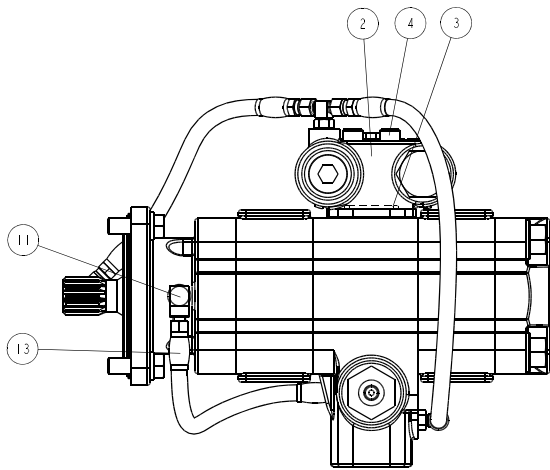

ITEM	DESCRIPTION	QTY
1	MOTOR, 2-SPD HYD	1
2	BRAKE VALVE ASSY	1
3	O-RING	1
4	CAPSCREW	4
5	LOCKWASHER	4
6	CAPSCREW	4
7	O-RING	1
8	ELBOW FITTING	1
9	ADAPTER	1
10	TEE, -4 ORB	2
11	REDUCER ELBOW	1
12	HOSE ASSY 16-IN.	1
13	HOSE ASSY	1
14	SWIVEL NUT 90 DEG. E	3
15	CAP NUT	1