

# BRADEN

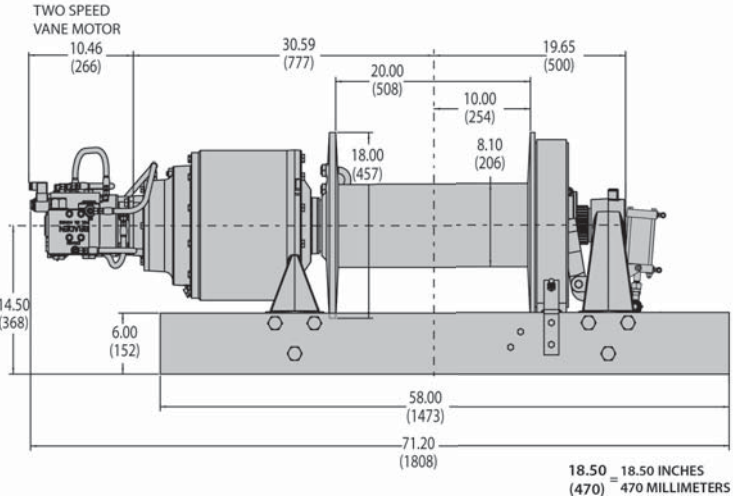

Authorized Distributor:  
Pacific Marine & Industrial  
www.pacificmarine.net  
info@pacificmarine.net

## MODEL HP75B UP TO 75,000-POUND LINEPULL

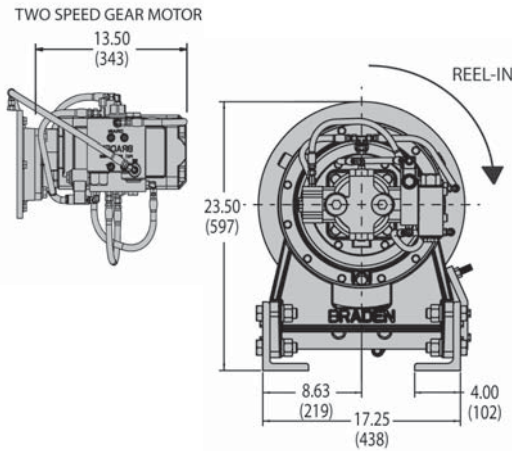

- 75,000 lbs. First Layer
- Planetary Gearing for High Efficiency
- Gear or Vane Motor Available

- Multi-disc Wet Brake for Firm Hold
- Air Actuated Sliding Drum Clutch
- Patented Brake Valve for Smooth/Reliable Load Control

### Specifications

#### HP75A-LP-122089/045-01

8.92/4.46 cu in. 2-Speed Gear Motor (146/73cc)  
2670 PSI (184 bar) @ 60 gpm (227 lpm)  
Wire Rope Diameter: 1"

	LOW SPEED				HIGH SPEED			
	LINE PULL		LINE SPEED		LINE PULL		LINE SPEED	
	LB	KG	FPM	MPM	LB	KG	FPM	MPM
1	75,000	34,020	26	8	37,500	17,010	55	17
2	61,500	27,900	32	10	30,700	13,930	67	20
3	52,100	23,630	37	11	26,000	11,790	80	24
4	45,200	20,500	43	13	22,600	10,250	92	28

\* Rope capacity based on 90% of theoretical

#### HP75A-LP-088130/065-01

13.00/6.50 cu in. 2-Speed Rineer Motor (213/106cc)  
2400 PSI (165 bar) @ 50 gpm (190 lpm)  
Wire Rope Diameter: 1"

	LOW SPEED				HIGH SPEED			
	LINE PULL		LINE SPEED		LINE PULL		LINE SPEED	
	LB	KG	FPM	MPM	LB	KG	FPM	MPM
1	75,000	34,100	23	7	32,700	14,830	44	13
2	61,500	28,000	28	9	26,800	12,160	54	16
3	52,100	23,700	33	10	22,700	10,300	64	20
4	45,200	20,600	38	12	19,700	8,940	74	23

\* Rope capacity based on 90% of theoretical

### Wire Rope Storage Capacities

-01 DRUM CAPACITY [inches] (8.10" B x 18.00" F x 20.00" W)					
	1	2	3	4	5
7/8"	48	103	168	243	327
1"	42	94	155	226	
1 1/8"	38	86	143	209	

-01 DRUM CAPACITY [meters] (206 B x 457 F x 508 W)					
	1	2	3	4	5
7/8"	14	31	51	74	99
1"	13	29	47	69	
1 1/8"	12	26	44	64	