

BRADEN



Authorized Distributor:
Pacific Marine & Industrial
www.pacificmarine.net
info@pacificmarine.net

MODEL HP160A

Up To 160,000-POUND LINEPULL

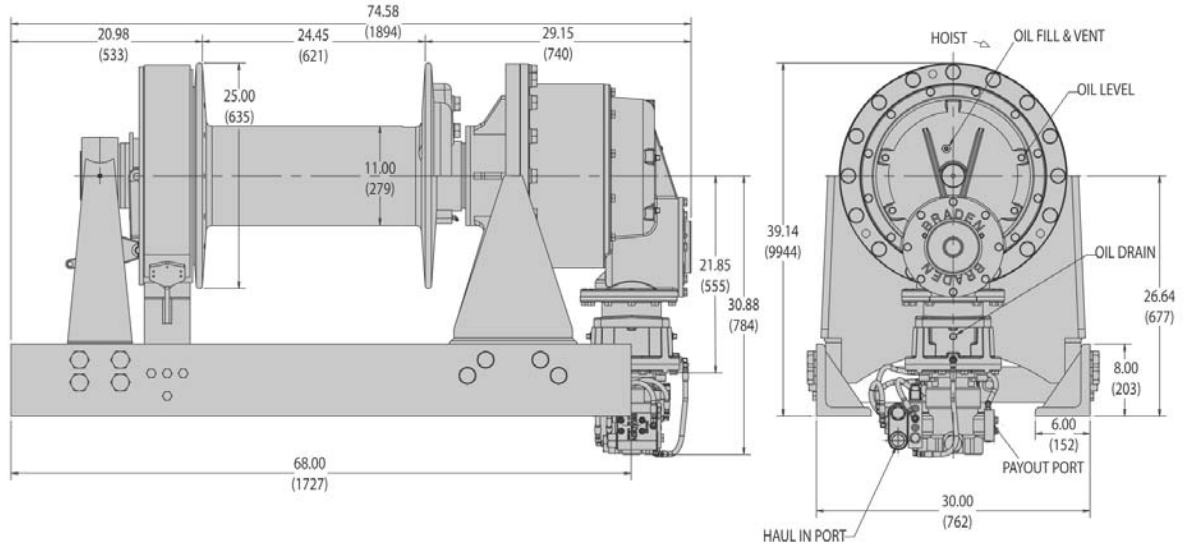

- 160,000 lbs. First Layer
- Planetary Gearing for High Efficiency
- Compact Low Profile Design

- Slide Drum Clutch Avoiding Release Under Load
- Multi-disc Wet Brake for Firm Hold
- Patented Brake Valve for Smooth/Reliable Load Control

Specifications

HP160A-206R15/075-01

15.0/7.5 cu in. 2-Speed Motor (245/123 cc)
 2990 PSI (206 bar) @ 70 gpm (265 lpm)
 Wire Rope Diameter: 1 1/4"

	LOW SPEED				HIGH SPEED				ROPE CAPACITY	
	LINE PULL		LINE SPEED		LINE PULL		LINE SPEED			
	LB	KG	FPM	MPM					FT	M
1	160,020	72,736	16	5	72,520	32,964	32	10	55	17
2	132,900	60,409	19	6	60,220	27,373	39	12	121	37
3	113,640	51,655	22	7	51,500	23,409	45	14	198	60
4	99,250	45,114	26	8	44,980	20,445	52	16	287	87

* Rope capacity based on 90% of theoretical

Wire Rope Storage Capacities

-01 DRUM CAPACITY [inches] (11.00" B x 25.00" F x 24.45" W)					
	1	2	3	4	5
1"	67	145	235	336	448
1 1/4"	55	121	198	287	
1 1/2"	47	105	174	254	

-01 DRUM CAPACITY [meters] (279mm B x 635 mm F x 621mm W)					
	1	2	3	4	5
1"	20	44	72	102	137
1 1/4"	17	37	60	87	
1 1/2"	14	32	53	77	

LIT2383 R1 9-2009

PACCAR
WINCH DIVISION

MAKERS OF THE FINEST WINCH, HOIST, AND DRIVE SYSTEMS