

The BRADEN HP100 is ready to conquer the challenges of the oilfield. This compact and powerful recovery winch delivers best-in-class line-pull and robust performance in the toughest applications. Precise load control and ease of service make the BRADEN HP100 the top choice for operators and fleet owners alike.

Features/Benefits

- Sealed three-stage high-efficiency planetary reduction gearing provides continuous duty performance for long pulls
- Negative-draft jaw clutch ensures full engagement under load
- Patented BRADEN brake valve enables smooth operation and precise load control
- Ferrule anchor system facilitates rope installation and removal
- Easy-to-access lubrication points allow servicing with wire rope in place
- SAE J706 compliance-tested to ensure safe and secure operation

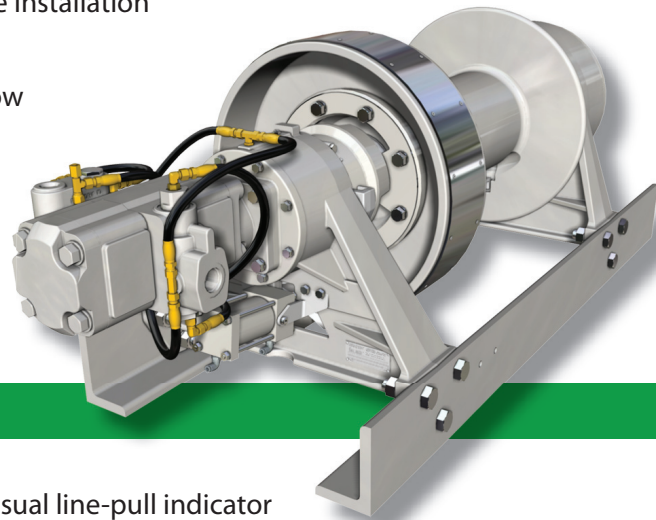
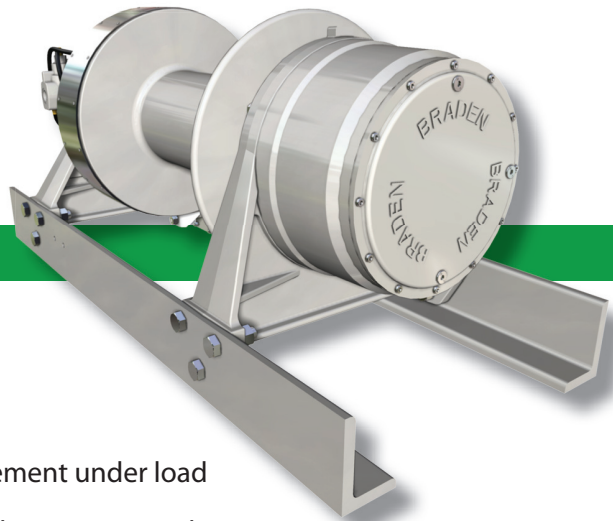

Options

- Electronic load monitor for lighted visual line-pull indicator and audible overload warning
- Clutch engagement indicator provides load status without need for direct line-of-sight to winch
- Piston motor with SAE "D" mounting configuration



Authorized Distributor:
Pacific Marine & Industrial
www.pacificmarine.net
info@pacificmarine.net

HP100B PLANETARY WINCH

100,000 lb (45,340 kg)

BRADEN®

Performance

HP100B-123114/051-01

RATIO		123:1		123:1				
MOTOR	Low: 114 (11.47 cu in.)	Hi: 051 (5.1 cu in.)	Low: 114 (188 cc)	Hi: 045 (83.6 cc)				
PRESSURE	2,630 psi		181 bar					
FLOW	60 gpm		227.1 lpm					
WIRE ROPE DIA	1.125 in.		28 mm					
LAYER	LINE PULL (lb)	LINE SPEED (fpm)	LINE PULL (lb)	LINE SPEED (fpm)	LINE PULL (kg)	LINE SPEED (mpm)	LINE PULL (kg)	LINE SPEED (mpm)
1	100,000	21	42,530	52	45,355	6	19,290	16
2	81,820	26	34,780	64	37,110	8	15,775	20
3	69,230	31	29,430	75	31,400	9	13,350	23
4	60,000	36	25,510	87	27,215	11	11,570	27
WEIGHT	1,650 lb		748.4 kg					

Drum Capacity

-01 DRUM

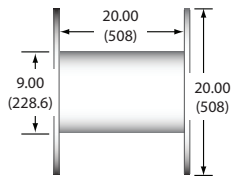

DIMENSIONS IN INCHES (MM)

WIRE ROPE STORAGE, ft

LAYER	1	2	3	4	D/d
-------	---	---	---	---	-----

WIRE ROPE DIA 1.125 in. 42 94 155 226 9:1

WIRE ROPE STORAGE, m

WIRE ROPE DIA 28 mm 13 29 47 69 9:1

Dimensions

DIMENSIONS IN INCHES (MM)



Authorized Distributor:
Pacific Marine & Industrial
www.pacificmarine.net
info@pacificmarine.net

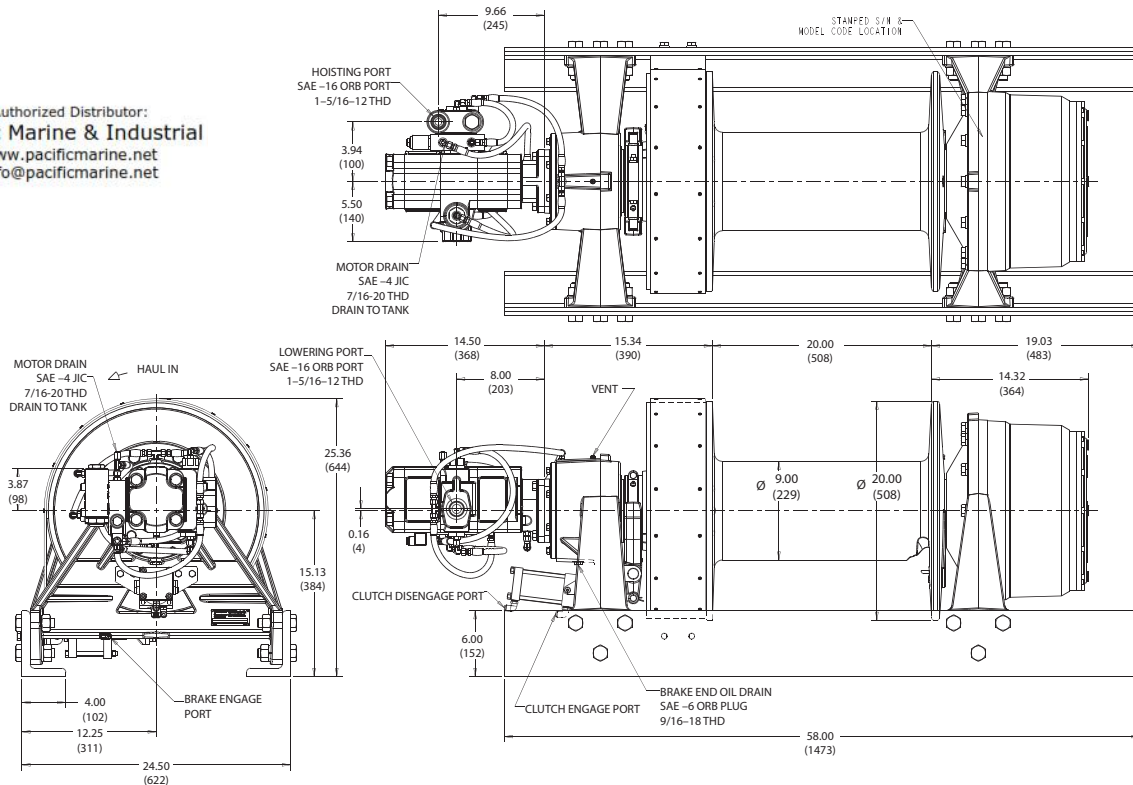

www.paccarwinch.com