

BRADEN

CH400B PLANETARY HOIST

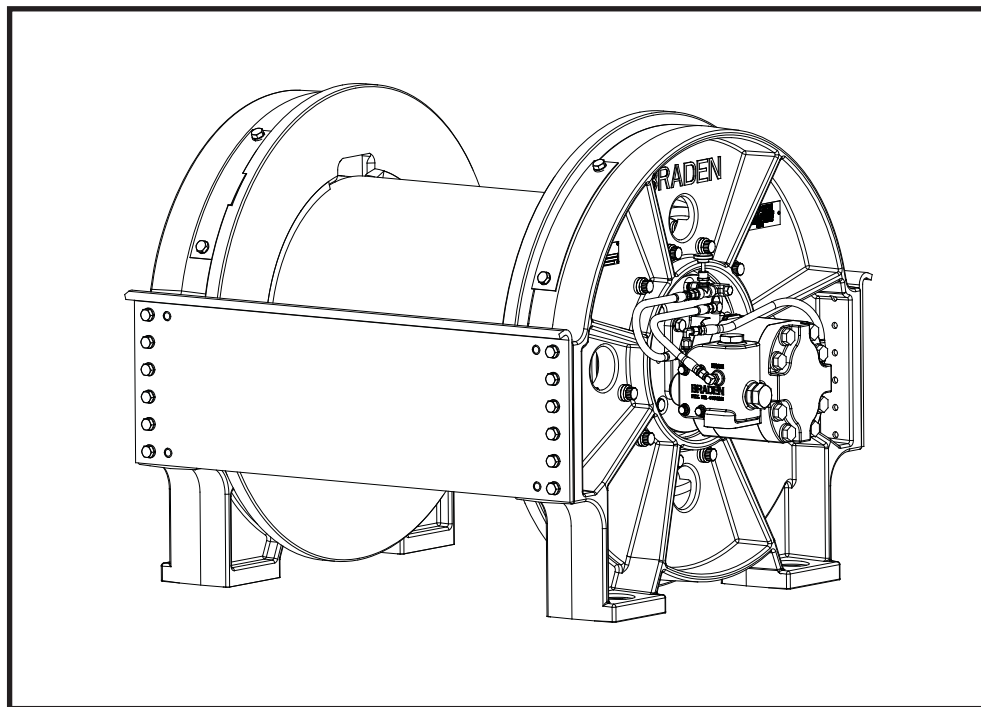

INSTALLATION, MAINTENANCE AND SERVICE MANUAL



Authorized Distributor:
Pacific Marine & Industrial
www.pacificmarine.net
info@pacificmarine.net

LIT2419 R2
7-2010
PRINTED IN U.S.A.

PACCAR WINCH DIVISION
P.O. BOX 547 BROKEN ARROW, OK U.S.A. 74013
PHONE (918) 251-8511 FAX (918) 259-1575
www.paccarwinch.com

Pacific Marine & Industrial - www.pacificmarine.net

TABLE OF CONTENTS

FOREWORD	3
MODEL & SERIAL NUMBER LOCATION	3
EXPLANATION OF MODEL NUMBER	3
GLOSSARY OF TERMS	4
GENERAL SAFETY RECOMMENDATIONS	5
THEORY OF OPERATION.....	6
HOIST INSTALLATION.....	8
HYDRAULIC CIRCUIT	9
PREVENTIVE MAINTENANCE.....	10
WEIGHTS, OIL CAPACITIES & SPECIAL TOOLS	12
RECOMMENDED PLANETARY GEAR OIL.....	12
TROUBLESHOOTING	13
SERVICE PRECAUTIONS.....	16
MAIN COMPONENTS.....	16
HOIST DISASSEMBLY.....	17
HOIST ASSEMBLY.....	19
DRUM SUPPORT END BRACKET SERVICE	20
HOIST DRIVE SERVICE.....	22
BRAKE CYLINDER SERVICE	26
OVER-RUNNING CLUTCH SERVICE	28
PLANETARY CARRIER SERVICE.....	29
INTERMEDIATE PLANET CARRIER SERVICE	30
FINAL PLANET CARRIER SERVICE.....	31
BRAKE VALVE SERVICE.....	32
RECOMMENDED FASTENER TORQUE	35
METRIC CONVERSION CHART	36



Authorized Distributor:
Pacific Marine & Industrial
www.pacificmarine.net
info@pacificmarine.net

FOREWORD

Read this entire publication and retain it for future reference.

The minimum service intervals specified are for operating hours of the prime mover.

The following service instructions have been prepared to provide assembly, disassembly and maintenance information for the BRADEN Model CH400B series hoist. Before doing any work on these units, all assembly and disassembly instructions should be read and understood.

Pictures in this manual may show details or attachments that are different from your hoist. Also, some components have been removed for illustrative purposes. Illustrations and pictures in this manual are of a "typical" unit sold through our distribution channels. Some hoists, particularly those sold directly to original equipment manufacturers, may differ in appearance.

If a question arises regarding your BRADEN hoist, please contact BRADEN Service Department for the latest available information.

Telephone- 1-918-251-8511

08:00-16:30 Central Time Zone, Monday thru Friday

FAX- 1-918-259-1575

www.paccarwinch.com

Serial Numbers and Model Number are stamped into the motor end bracket as shown at right. Always refer to the Serial Number and Model Number when requesting information or service parts.

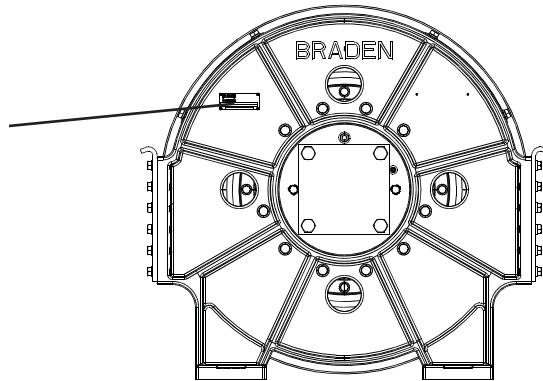

EXPLANATION OF MODEL NUMBER

CH	400	B	87	120	-	01	-	G	-	1
CONSTRUCTION HOIST	MAX RATING	DESIGN RATING	GEAR RATIO	MOTOR SIZE		DRUM SIZE		DRUM OPTION		OPTION

CH DESIGNATES CONSTRUCTION HOIST

400 DESIGNATES 40,000 LB DESIGN FIRST LAYER LINE PULL

B DESIGNATES THE MODEL SERIES RELATING TO DESIGN CHANGES

87 DESIGNATES TOTAL GEAR REDUCTION

120 DESIGNATES HYDRAULIC MOTOR DISPLACEMENT IN CU IN/REV (120 = 12.0 CU IN REV)

01 DESIGNATES THE DRUM OPTION

G DESIGNATES OTHER DRUM OPTIONS (G = GROOVED; M = MACHINED; P = RATCHET AND PAWL
U = UNDERWOUND)

1 PERMITS TESTING AND INSPECTION PER API 2C FOR OFFSHORE CRANES

Safety Informational callouts used in this manual include:

⚠ WARNING ⚠

WARNING – This emblem is used to warn against hazards and unsafe practices which could result in severe personal injury or death if proper procedures are not followed.

⚠ CAUTION ⚠

CAUTION – This emblem is used to warn against potential or unsafe practices which could result in personal injury or product or property damage if proper procedures are not followed.

GLOSSARY OF TERMS

Brake Valve - A hydraulic counterbalance valve is usually bolted to the hoist port of the hydraulic motor. It allows oil to flow freely through the motor in the hoisting direction. When oil pressure tries to rotate the motor in the lowering direction, the brake valve blocks the flow of oil out of the motor until the internal static brake is released. It then controls lowering speed based on the load and flow of oil to the motor. All the heat generated by controlling the speed of the load is dissipated by the hydraulic system, not by the internal static brake.

Grooved Drum - A cable drum with grooves on the barrel to ensure the first layer of cable spools properly onto the drum. The grooves can be cast or machined into the drum, or cast or machined into separate pieces that are mechanically fastened to the drum. **NOTE:** *Only one size cable can be used on a grooved drum.*

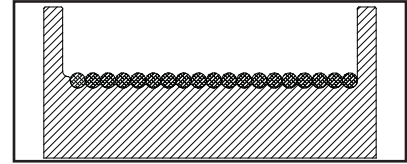

Sprag or Over-Running Clutch - A mechanical one-way clutch on the input shaft of the hoist, between the input shaft and the static mechanical brake. The clutch allows the input shaft to turn freely in the direction required to spool cable onto the drum (i.e. lift a load), then immediately locks the hoist gear train to the mechanical brake when the hoist is stopped, holding the load in place.

Static, Mechanical, or Load-Holding Brake - A multi-disc, spring applied, hydraulically released brake that works together with the sprag clutch to hold a suspended load. This brake is not designed to stop a load being lowered, but holds the load in place when the hoist is not being operated.

First Layer Line Pull Rating - The maximum rated line pull (in pounds or kilograms) on the first layer of cable. The maximum rating for any particular hoist is based on maintaining an acceptable structural design factor and service life. Certain combinations of drum, gear ratio, motor and hydraulic pressure, may reduce this rating.

First Layer Line Speed Rating - The maximum rated line speed (in feet or meters per minute) on the first layer of cable. Certain combinations of drum, gear ratio, motor and hydraulic flow may reduce or increase this rating.

D/d Ratio - The ratio of cable drum barrel diameter (D) to wire rope diameter (d). Current ANSI standards require a minimum of 17:1.

EXAMPLES:

If you know the cable diameter you want to use, multiply it by 17 to get the MINIMUM cable drum barrel diameter. (i.e. ½ inch wire rope X 17 = 8.5 inches - this is the minimum hoist barrel diameter)

If you know the barrel diameter, divide it by 17 to get the MAXIMUM wire rope diameter.

(i.e. 10 inch barrel diameter / 17 = 0.588, or 9/16 inch - this is the maximum wire rope diameter)

Cable Drum Dimensions -

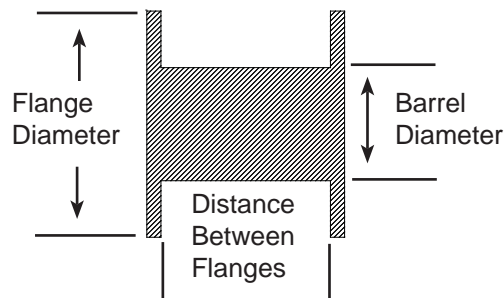

Fleet Angle - The angle between the wire rope's position at the extreme end wrap on a drum, and a line drawn perpendicular to the axis of the drum, through the center of the nearest fixed sheave or load attachment point.

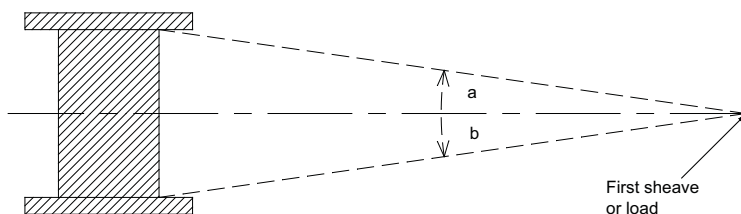

First sheave or load should be centered between the drum flanges, so that angle "a" and angle "b" are equal.

Angles "a" and "b" should be a minimum of ½ degree and a maximum of 1½ degrees.

Wrap - A single coil of wire rope wound on a drum.

Layer - All wraps of wire rope on the same level between drum flanges.

Freeboard - The amount of drum flange that is exposed radially past the last layer of wire rope. Minimum freeboard varies with the regulatory organization. ASME B30.5 requires ½ in. minimum freeboard.



GENERAL SAFETY RECOMMENDATIONS

Safety for operators and ground personnel is of prime concern. Always take the necessary precautions to ensure safety to others as well as yourself. To ensure safety, the prime mover and hoist must be operated with care and concern by the operator for the equipment, and a thorough knowledge of the machine's performance capabilities. The following recommendations are offered as a general safety guide. Local rules and regulations will also apply.

⚠ WARNING ⚠

FAILURE TO OBEY THE FOLLOWING SAFETY RECOMMENDATIONS MAY RESULT IN PROPERTY DAMAGE, PERSONAL INJURY, OR DEATH.

1. Be certain equipment (boom, sheave blocks, pendants, etc.) is either lowered to the ground or blocked securely before servicing, adjusting, or repairing hoist.
2. Be sure personnel are clear of work area BEFORE operating hoist.
3. Read all warning and caution tags provided for safe operation and service of the hoist and become familiar with the operation and function of all controls before operating the hoist.
4. Inspect rigging and hoist at the beginning of each work shift. Defects should be corrected **immediately**. Do not operate a hoist with defects.
5. Keep equipment in good operating condition. Perform scheduled servicing and adjustments listed in the "Preventive Maintenance" section of this manual.
6. An equipment warm-up procedure is recommended for all start-ups and essential at ambient temperatures below +40°F (+4°C). Refer to "Warm-up Procedure" listed in the "Preventive Maintenance" section of this manual.
7. Do not exceed the maximum pressure (PSI, kPa) or flow (GPM, lpm) stated in the hoist specifications found in the specific sales brochure.
8. Operate hoist line speeds to match job conditions.
9. Protective gloves should be used when handling wire rope.
10. **Never** attempt to handle wire rope when the hook end is not free. Keep all parts of body and clothing clear of cable rollers, cable entry area of fairleads, sheaves and hoist drum.
11. When winding wire rope on the hoist drum, **never** attempt to maintain tension by allowing wire rope to slip through hands. Always use "Hand-Over-Hand" technique.
12. Never use wire rope with broken strands. Replace wire rope that is damaged. Refer to wire rope supplier manual.
13. **Do not** weld on any part of the hoist without approval from PACCAR Winch Engineering.
14. Use only recommended hydraulic oil and gear lubricant.
15. Keep hydraulic system clean and free from contamination at all times.
16. Use correct size cable anchor for wire rope and pocket in hoist drum.
17. **Do not** use knots to secure or attach wire rope.
18. The BRADEN designed wire rope anchors are not intended to support the rated load. **ALWAYS** maintain a minimum of five (5) wraps of wire rope on the drum. It is recommended that the last five (5) wraps of wire rope be painted bright red to serve as a visual reminder.
19. **Never** attempt to clean, oil or perform any maintenance on a machine with the engine or prime mover running, unless instructed to do so in this manual.
20. **Never** operate hoist controls unless you are properly positioned at the operators station and you are sure personnel are clear of the work area.
21. Assure that personnel who are responsible for hand signals are clearly visible and that the signals to be used are thoroughly understood by everyone.
22. Ground personnel should stay in view of the operator and clear of the hoist drum. **Do not** allow ground personnel near wire rope under tension. A safe distance of 1½ times the working length of the wire rope should be maintained.
23. Install guarding to prevent personnel from getting any part of body or clothing caught at a point where the cable is wrapped onto the drum or drawn through guide rollers or potential "pinch points".
24. Install switches or valves that will shut off power to the hoist, in locations where they can be reached by anyone entangled in the wire rope before being drawn into the hoist or any "pinch point".
25. "Deadman" controls, which automatically shut off power to the hoist whenever the operator leaves his station or releases the hoist control lever, should be installed whenever practical.
26. Never allow anyone to position any part of body under a suspended load.
27. Avoid sudden "shock" loads or attempting to "jerk" a load free. This type of operation may cause heavy loads, in excess of rated capacity, which may result in failure of wire rope, hoist or crane structure.
28. Whenever possible, install the hoist in a location that is not immediately adjacent to a "normal" operator's station.
29. All hoist controls shall be located within easy reach of the operator. The controls shall be installed in such a location that the operator is removed from the electrical path to ground if the load, rigging, or wire rope come in contact with or within proximity to an electrically energized conductor.
30. Before operating the hoist, be sure ALL safety procedures for the equipment or vehicle the hoist is mounted on are properly followed and/or in place.



Authorized Distributor:
Pacific Marine & Industrial
www.pacificmarine.net
info@pacificmarine.net

THEORY OF OPERATION

DESCRIPTION OF HOIST

The hoist is made up of the following sub-assemblies and parts:

1. Hydraulic motor, brake valve and motor adapter
2. Drum and drum support assembly
3. Motor end support
4. Tie plates
5. Brake clutch assembly
6. Drive assembly with multiple disc parking brake and internal gearing

DUAL BRAKE SYSTEM

DESCRIPTION

The dual brake system consists of a dynamic brake system and a static brake system.

The dynamic brake system has two operating components:

1. Brake valve assembly
2. Hydraulic motor

The brake valve is basically a counterbalance valve. It contains a check valve to allow free flow of oil to the motor in the haul-in direction and a pilot operated, spring loaded spool valve that blocks the flow of oil out of the motor when the control valve is placed in neutral. When the control valve is placed in the pay-out position, the spool valve remains closed until sufficient lowering pressure is applied to the end of the spool to shift it against spring pressure and open a passage. After the spool valve cracks open, the lowering pressure becomes flow dependent and modulates the spool valve opening which controls the lowering speed. See figures 1, 2 and 3.

Figure 1

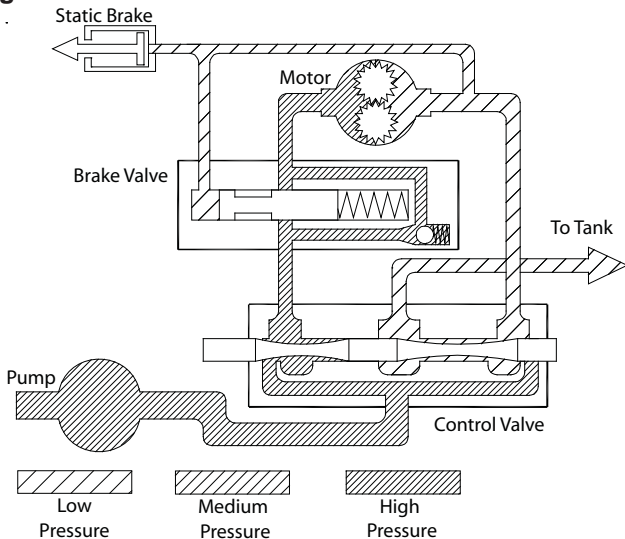

Figure 2

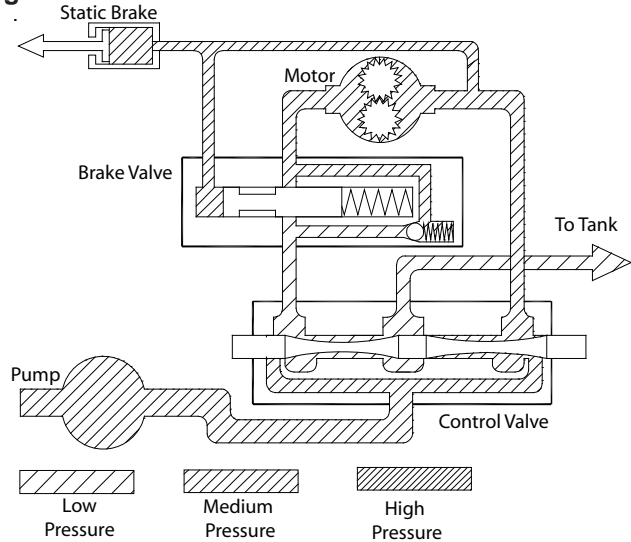
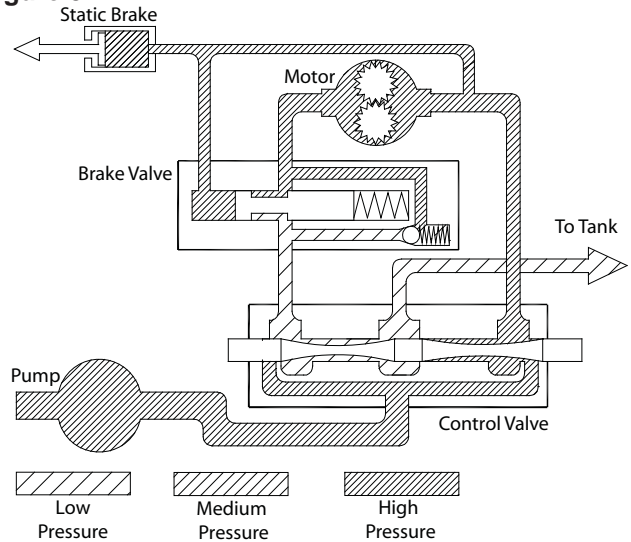

Figure 3



The static brake system has three operating components:

1. Spring applied, hydraulically released multiple friction disc brake pack
2. Brake clutch assembly
3. Hydraulic piston and cylinder

The static brake is released by lowering pressure at a pressure lower than that required to open the brake valve. This sequence assures that dynamic braking takes place in the brake valve and little, if any, heat is absorbed by the friction brake.

The friction brake is a load holding brake only and has nothing to do with dynamic braking or rate of descent of a load. The inner race of the brake clutch is a splined coupling between the motor and the primary sun gear. The outer race is splined to the friction discs in the brake pack, while steel separator plates are splined to the stationary housing. The brake clutch allows this shaft to turn freely in the haul-in direction, and locks up to force the brake discs to turn with the shaft in the pay-out direction. See figures 4 and 5.

Figure 4

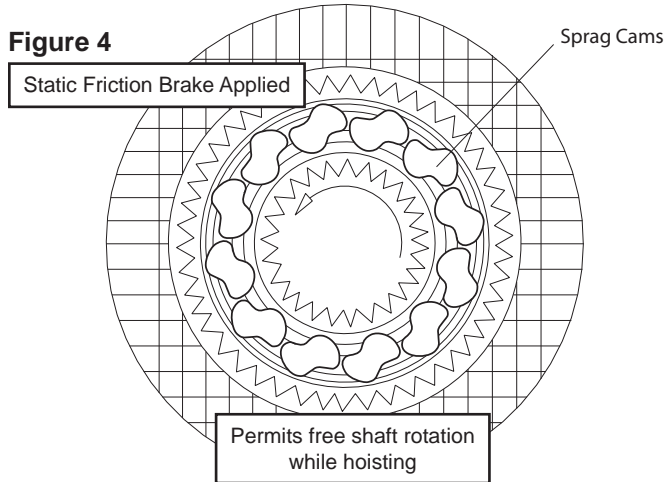
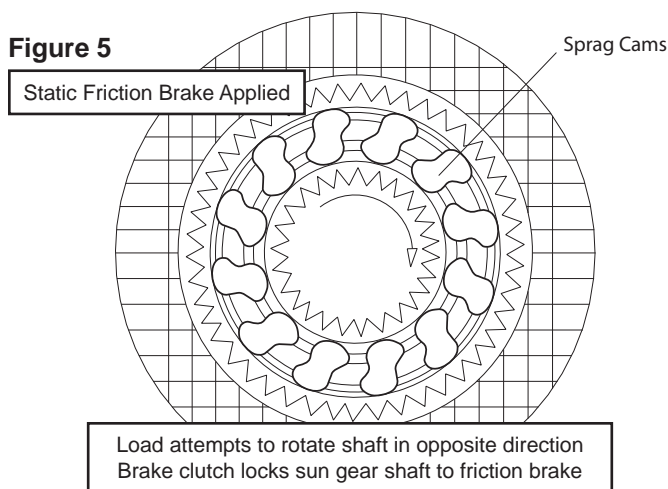

Figure 5



Spring pressure on the steel end friction brake discs prevent the brake discs from turning until the hydraulic cylinder and piston are pressurized, releasing the force on the brake discs and creating clearance between the friction and steel discs..

OPERATION

When hauling-in cable, or hoisting a load, the motor shaft and hoist gear train turn freely as the sprag cams lay over between the inner and outer races of the brake clutch. See figure 4.

The multiple disc friction brake remains fully engaged and the hoist is not affected by any braking action when hoisting. See figure 1.

When hoisting is stopped, the load tries to turn the hoist drum, gear train and primary sun gear in the reverse direction. This reversed input to the inner race of the brake clutch causes the sprag cams to instantly roll upward and lock the shaft to the fully engaged friction brake. See figure 5.

When the hoist is powered in the pay-out or lowering direction, the motor cannot rotate until sufficient lowering pressure is present to release the brake and open the brake valve. See figures 2 and 3. The friction brake will completely release at a pressure lower than that required to open the brake valve. The extent to which the brake valve opens determines the amount of oil that can flow through the motor, which is directly related to the drum speed of the hoist. Increasing the flow of oil to the hoist motor causes the pilot pressure to rise which increases the opening in the brake valve, allowing more oil to flow through the motor and increasing the drum speed. Decreasing this oil flow causes the pilot pressure to drop, reducing the opening in the brake valve which slows the motor and hoist speed.

The friction brake receives very little, if any, wear in the pay-out or lowering operation. All of the heat generated by lowering and stopping a load is absorbed by the hydraulic oil where it can be readily dissipated.

When the control valve is shifted to neutral, pilot pressure drops closing the brake valve spool, stopping the motor and the load. The friction brake then engages and holds the load after the brake valve has closed.

When lowering a load very slowly for precise positioning, no oil flow actually occurs through the pilot operated spool in the brake valve. Pressure builds up to a point where the friction brake will release sufficiently to allow the load to rotate the motor through its own internal leakage. This feature results in a very slow speed and extremely accurate positioning.

HOIST OPERATION

The input section of the drive assembly is bolted to the motor end support and cannot rotate. The drive housing is the output member of the gear set and is bolted to the hoist drum. The motor shaft is directly coupled to the primary sun gear through the inner race of the brake clutch. The motor turns the primary sun gear which drives three successive planetary gear sets, turning the drive housing and the hoist drum.

In the haul-in direction, hydraulic oil flows through a large check valve in the brake valve and turns the motor in the free rotating direction of the brake clutch, driving the gear train and hoist drum. The friction brake remains fully engaged.

In the pay-out direction, oil flow through the motor is initially blocked by a spool in the brake valve. Oil pressure supplied to the motor through the control valve is piloted to the friction brake and the brake valve spool. The friction brake is released at a lower pressure than that required to shift the brake valve spool. When pressure is sufficient to shift the brake valve spool, oil is allowed to flow through the motor, rotating the hoist gear train and drum.

HOIST INSTALLATION

1. The hoist should be mounted with the centerline of the cable drum in a horizontal position. The mounting plane of the hoist may be rotated in any position around this centerline providing the vent in the motor adapter is above the centerline of the cable drum. The vent should be as close to top dead center as possible.
2. When mounting the hoist, use all four (4) mounting holes and grade eight (8) bolts and nuts. Evenly tighten the nuts to the torque in the "Recommended Fastener Torque" chart. Make certain the hoist drum is centered behind the first sheave and the fleet angle does not exceed 1½ degrees. The hoist should also be mounted perpendicular to an imaginary line from the center of the drum to the first sheave to ensure even spooling.

Refer to "Dimensional Drawing" on page 10 and in sales brochure for bolt hole size and pattern.

It is important that the hoist is mounted on a surface that will not flex when the hoist is in use, and cause binding of the gear train. Binding in the gear train will result in accelerated wear and heat. Also, the mounting surface should be flat with +/- 0.020 inches. If necessary, install shims under the hoist mounting pads to achieve even mounting.

3. The hydraulic lines and components that operate the hoist should be of sufficient size to assure minimum back pressure at the hoist. The back pressure at the motor must not exceed 100 psi (690 kPa) to maintain full brake system design factor and optimum motor seal life for gear motors, **30 psi (207 kPa) for piston motors**. On **All** piston motors and on gear motors with backpressures above 50 psi, an external line should be plumbed directly to tank from the motor case drain. On tandem motors (two inlet and two outlet ports on the motor) that have two case drain ports, the larger center case drain should be plumbed to tank.

The hoist directional control valve must be a three position four way valve with a motor spool such that when the valve is in the center position both work ports are open to tank (open center, open port), and must be spring-centered and without detents.

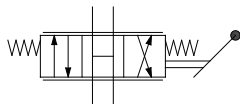

Recommended Control Valve Schematic

⚠ WARNING ⚠

DO NOT use a control valve with any detents or latching mechanism that would hold the control valve in an actuated or running position when the operator releases the control handle. Use of the wrong type of control valve could lead to unintentional operation of the hoist, which could result in property damage, personal injury, or death.

4. High quality hydraulic oil is essential for satisfactory performance and long hydraulic system component life.

Oil have 150 to 330 SUS viscosity at 100°F (38° C) and viscosity index of 100 or greater will give good results under normal temperature conditions. The use of an oil having a high viscosity index will minimize cold start trouble and reduce the length of warm-up periods. A high viscosity index will minimize changes in viscosity with corresponding changes in temperature.

Maximum cold weather start-up viscosity should not exceed 5,000 SUS with a pour point at least 20°F (11° C) lower than the minimum ambient temperature.

Under continuous operating conditions the temperature of the oil at any point in the system must not exceed 180° F (82° C). 120° F (49° C) to 140° F (60° C) is generally considered optimum.

In general terms:

For continuous operation at ambient temperatures between 50°F (10° C) and 110°F (43°C) use SAE 20W; for continuous operation between 10°F (-12°C) and 90°F (32°C) use SAE 10W; for applications colder than 10°F (-12°C), contact the BRADEN Service Department. The use of multi-viscosity oils is generally not recommended.

For hoist gear oil, refer to "Lubricant Specifications" in the "Preventive Maintenance and Specifications" section.

5. The hydraulic oil filter should have a 10 micron nominal rating and be full flow type.
6. The vent plug in the motor adapter (and aux brake end if equipped) must be located as close to top dead center as possible. If the hoist is mounted on a pivoting surface, the vent plug must remain above the centerline of the cable drum to prevent gear oil leakage.
7. Refer to "Dimensional Drawing" for relationship between drum rotation and which port is pressurized.



Authorized Distributor:
Pacific Marine & Industrial
www.pacificmarine.net
info@pacificmarine.net

WIRE ROPE INSTALLATION

Remove both sheet metal covers from the end bracket of the hoist. Pull the end of the cable through the opening in the drum flange and out through the end bracket as shown in figure 1. Form the cable around part 1 of the wedge as shown in figure 2, and pull the assembly into the anchor pocket (part 2 and the nut are not attached to part 1 at this time). Access the threaded rod attached to part 1 through the other opening in the end bracket and install part 2 and the nut. On large diameter cable, it may be necessary to hammer on the cable looped around part 1 in order to force it far enough into the anchor pocket to attach part 2.

It is important for the “dead” end of the cable to extend beyond the end of part 2, as shown in figure 2, but not far enough to come in contact with the end bracket when the hoist is operating. A load should be applied to the “live” end of the cable to properly seat the anchor. After the initial load is applied, check the tightness of the nut holding part 2 in place and tighten it if required. A minimum of five (5) wraps of wire rope should remain on the cable drum at all times. Refer to “General Safety Recommendations” for additional information.

Figure 1

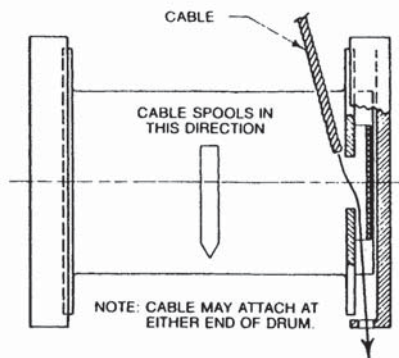
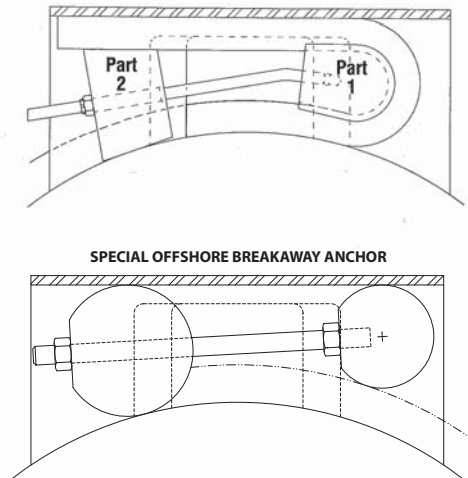
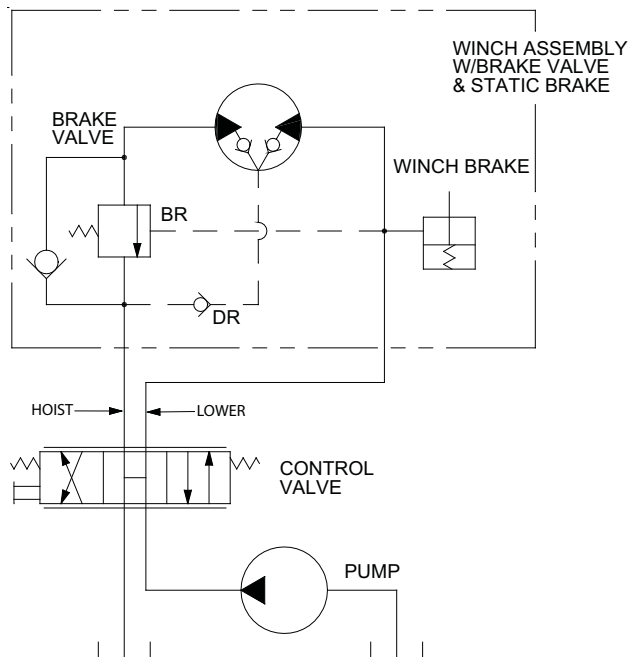

Figure 2



HYDRAULIC CIRCUITS

SINGLE SPEED CIRCUIT



2-SPEED SPEED CIRCUIT

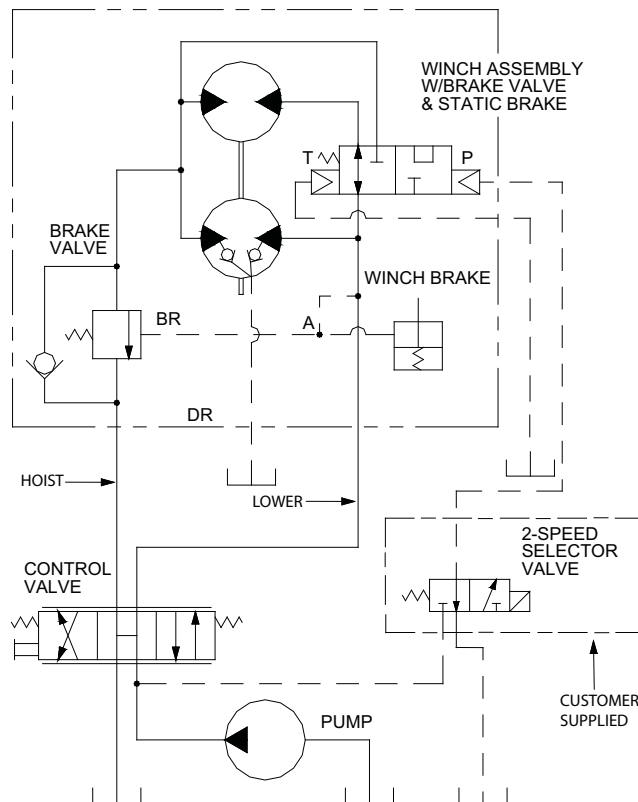

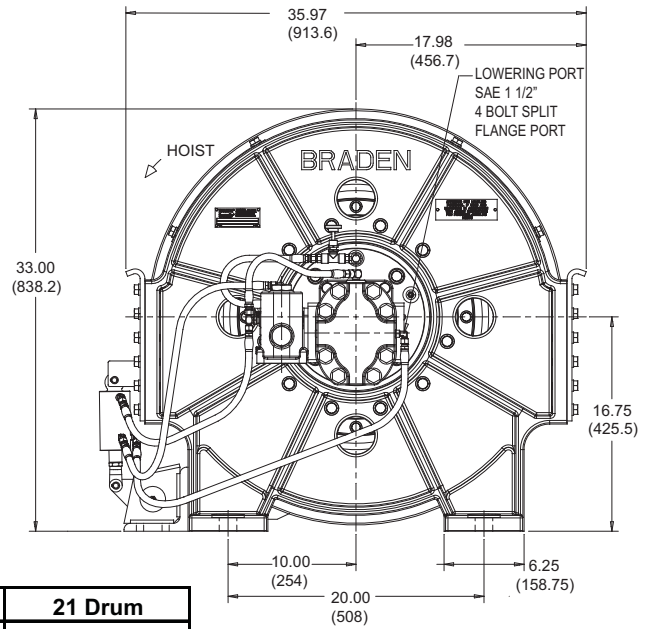
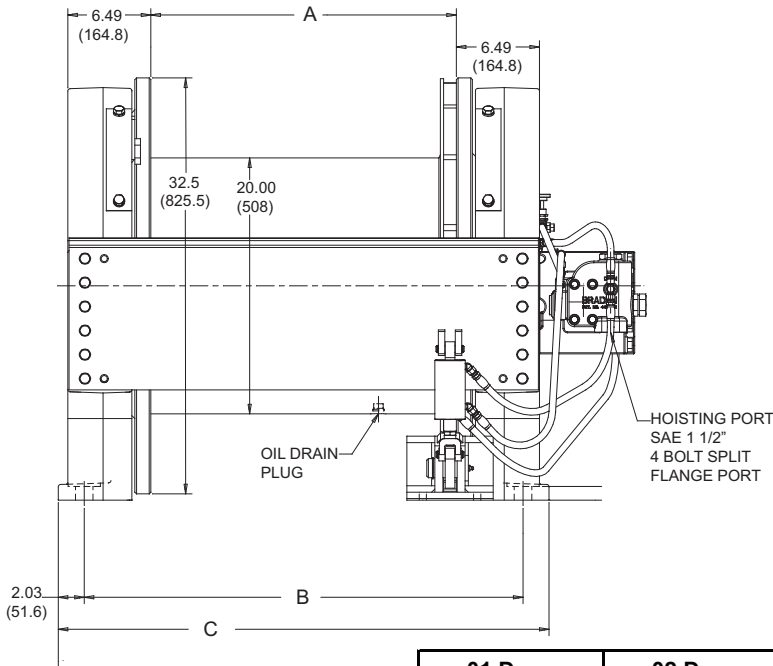

	01 Drum	02 Drum	21 Drum
A	23.88 (606.6)	38.12 (968)	54.62 (1387)
B	34.29 (871)	48.54 (1233)	69.1 (1755)
C	38.35 (974.1)	52.6 (1336)	69.1 (1755)

PREVENTIVE MAINTENANCE

A regular program of preventive maintenance for your planetary hoist is strongly recommended to minimize the need for emergency servicing and promote safe, reliable hoist operation.

Field experience, supported by engineering tests, indicates the three (3) service procedures listed below are the MOST critical to safe, reliable hoist operation and must be observed.

- **Regular Gear Oil Changes** – every 1000 hours or six (6) months
- **Use of Proper Gear Oil** – recommended type for prevailing ambient temperature
- **Annual Disassembly and Inspection of All Wear Items** – in compliance with American National Standards Institute (ANSI) specification B30.5c 1987 and American Petroleum Institute (API) recommended practice RP 2D section 3.

The following minimum service intervals are specified for operating hours of the prime mover.

1. Oil Level

The gear oil level should be checked every 500 operating hours or three (3) months, whichever occurs first. Oil level should be even with the centerline of the hoist drum visible in the sight gauge. If additional oil is needed, refer to "Recommended Planetary Gear Oil".

2. Oil Change

The gear oil should be changed after the first one hundred (100) hours of operation, then every 1,000 operating hours or six (6) months, whichever occurs first. The gear oil must be changed to remove wear particles that impede the reliable and safe operation of the brake clutch and erode bearings, gears and seals. Failure to change gear oil at these suggested minimum intervals may contribute to intermittent brake slippage which could result in property damage, severe personal injury or death.

Rotate the drum until the –8 drain plug is aligned with the lowest opening in the drum end support plate. Install a short piece of 1 inch pipe through the end plate. Reach through the pipe with a 5/16 hex Allen wrench and remove the –8 plug to drain the oil. Install the –8 plug and remove the 1 inch pipe when all the oil has been drained from the drum. Although gear oil circulates between the drive and the drum through holes in the primary ring gear, it is advisable to also remove the plug in the hoist drum.



Authorized Distributor:
Pacific Marine & Industrial
www.pacificmarine.net
info@pacificmarine.net

The gear oil should also be changed whenever the ambient temperature changes significantly and an oil from a different temperature range would be more appropriate. Oil viscosity with regard to ambient temperature is critical to reliable brake clutch operation. Make certain that the gear oil viscosity used in your hoist is correct for your prevailing ambient temperature. Failure to use the proper type and viscosity of planetary gear oil may contribute to brake slippage which could result in property damage, severe personal injury or death. Refer to "Recommended Planetary Gear Oil" for additional information.

3. Vent Plug

The vent plug is located directly above the hoist motor near the brake release port. It is very important to keep this vent clean and unobstructed. Whenever gear oil is changed, remove vent plug, clean in solvent and reinstall.

Do not paint over the vent or replace with a solid plug.

4. Hydraulic System

The original filter element should be replaced after the first fifty (50) hours of operation, then every 500 operating hours or three (3) months, or in accordance with the equipment manufacturer's recommendations.

5. Wire Rope

Inspect entire length of wire rope according to wire rope manufacturer's recommendations.

6. Mounting Bolts

Tighten all hoist base mounting bolts to recommended torque after the first one hundred (100) hours of operation, then every 1000 operating hours or six (6) months, whichever occurs first.

7. Warm-up Procedures

A warm-up procedure is recommended at each start-up and is essential at ambient temperatures below +40°F (4°C).

The prime mover should be run at its lowest recommended RPM with the hydraulic hoist control valve in neutral allowing sufficient time to warm up the system. The hoist should then be operated at low speeds, forward and reverse, several times to prime all lines with warm hydraulic oil, and to circulate gear lubricant through the planetary gear sets.

⚠ WARNING ⚠

Failure to properly warm up the hoist, particularly under low ambient temperature conditions, may result in temporary brake slippage due to high back pressures attempting to release the brake, which could result in property damage, severe personal injury, or death.

8. Recommended Planetary Gear Oil

Field experience, supported by extensive engineering tests, indicates the use of the proper planetary gear oil is essential to reliable and safe operation of the brake and obtaining long gear train life. Refer to "Recommended Planetary Gear Oil" for additional information.

⚠ WARNING ⚠

Failure to use the proper type and viscosity of planetary gear oil may contribute to intermittent brake clutch slippage which could result in property damage, severe personal injury or death. Some gear lubricants contain large amounts of EP (extreme pressure) and anti-friction additives which may contribute to brake slippage and damage to brake friction discs or seals. Oil viscosity with regard to ambient temperature is also critical to reliable brake operation. Our tests indicate that excessively heavy or thick gear oil may contribute to intermittent brake slippage. Make certain that the gear oil viscosity used in your hoist is correct for your prevailing ambient temperature.

9. Grease

Every 1,000 hours or six months grease drum support at grease fitting using an NLGI #2 Lithium complex base EP (extreme pressure) grease that meets or exceeds NLGI GC or GC/LP specifications..

10. Inspection

In compliance with ANSI specification number B30.5c1987 and API Recommended Practice RP 2D section 3, we recommend that the hoist be disassembled for a thorough inspection of all wear items every 2,000 hours of operation or twelve (12) months, whichever occurs first.

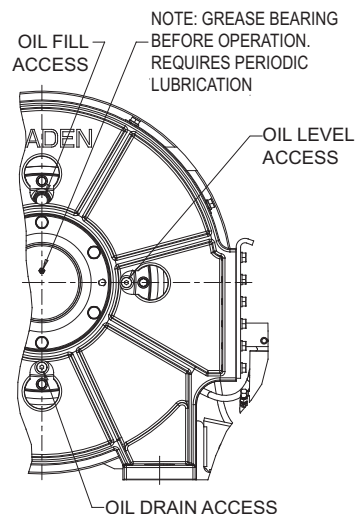

Authorized Distributor:
Pacific Marine & Industrial
www.pacificmarine.net
info@pacificmarine.net

WEIGHTS, OIL CAPACITIES AND SPECIAL TOOLS

DRUM	APPROXIMATE WEIGHT (LBS/KG)	APPROXIMATE OIL CAPACITY (QTS/L)
01	2700/1225	40/38
02	3370/1530	65/61.5
21	3800/1725	90/85

NOTE: All measurements shown are in inches.

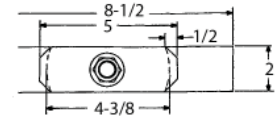

NOTE: If a press is available (with at least 5 inches of travel), only part (A) shown below is required (center hole not required). If a press is not available, all parts shown and listed below are required.

- a.) 1 each 3/4-16NF threaded rod, 9 inches long
- b.) 1 each 3/4-16NF nuts
- c.) 1 each 3/4 inch plain washer

12 pt. capscrew sockets 3/4" drive 12 point
 5/8" Proto P/N – J07510T
 Snap-On P/N – IMD202A

3/4" Proto P/N J07512T
 Snap-On P/N IMD242A

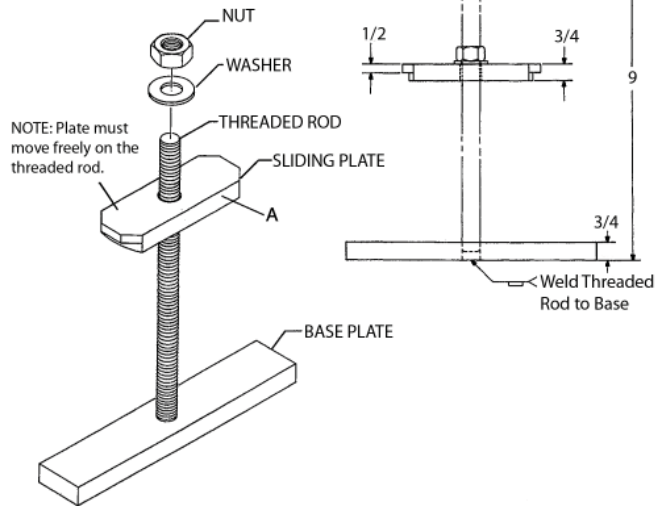

For simplicity, BRADEN has listed one (1) readily available product in each temperature range which has been tested and found to meet our specifications. This is not to say that other lubricant brands would not perform equally as well.

If the following lubricant brands are not available in your area, make certain your lubricant vendor supplies you with oil that is equivalent to those products listed below.

RECOMMENDED PLANETARY GEAR OIL

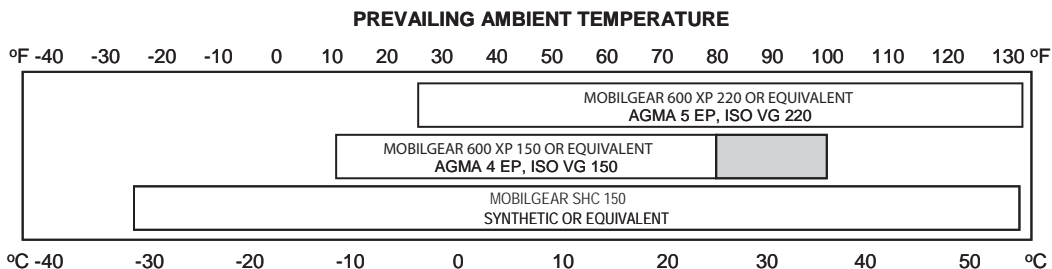

i NOTE: SHADED TEMPERATURE RANGE IN THE CHART ABOVE NOT RECOMMENDED FOR SEVERE APPLICATIONS SUCH AS: OFFSHORE CRANES, SUSTAINED FAST DUTY CYCLES OR FREQUENT LIFTING.

Planetary hoists are factory filled with Mobilgear 600 XP 150, or equivalent. Consult your oil supplier for other equivalent oils if required.

Mobil	Shell	Chevron	Texaco
Mobilgear 600 XP 150	Omala 150	Gear Compounds EP 150	Meropa 150
Mobilgear 600 XP 220	Omala 220	Gear Compounds EP 220	Meropa 220

TROUBLESHOOTING



If a hoist ever exhibits any sign of erratic operation, or load control difficulties (i.e. load creeping or chattering) appropriate troubleshooting tests and repairs should be performed immediately. Continued operation in this manner may result in property damage, serious personal injury or death.

TROUBLE	PROBABLE CAUSE	REMEDY
A The hoist will not lower the load or not lower the load smoothly.	<p>1. The friction brake may not be releasing as a result of a defective brake cylinder seal.</p> <p>NOTE: If the brake cylinder seal is defective you will usually find oil leaking from the hoist vent plug.</p> <p>2. Friction brake will not release as a result of damaged brake discs.</p>	<p>Check brake cylinder seal as follows:</p> <p>A. Disconnect the swivel tee from the brake release port. Connect a hand pump with accurate 0-2000 psi (0-13,000 kPa) gauge and shut-off valve to the -4 J.I.C. fitting in the brake release port.</p> <p>B. Apply 1000 psi (6,900 kPa) to the brake. Close shut-off valve and let stand for five (5) minutes.</p> <p>C. If there is any loss of pressure in five (5) minutes, the brake cylinder should be disassembled for inspection of the sealing surfaces and replacement of the seals. Refer to "Motor Support-Brake Cylinder Service".</p> <p>Disassemble brake to inspect brake discs.</p>
B Oil leaks from vent plug.	<p>1. Same as A1.</p> <p>2. Motor seal may be defective as a result of high system back pressure or contaminated oil.</p>	<p>Same as A1.</p> <p>System back pressure must not exceed 150 psi (1,030 kPa) for gear motor, 30 psi (207 kPa) for piston motor. Inspect hydraulic system for a restriction in the return line from the control valve to the reservoir. Be sure control valve and plumbing is properly sized to hoist motor.</p> <p>Oil analysis may indicate contamination has worn motor shaft and seal. Thoroughly flush entire hydraulic system and install new filters and oil. Install new motor seal.</p>



Authorized Distributor:
Pacific Marine & Industrial
www.pacificmarine.net
info@pacificmarine.net

TROUBLE	PROBABLE CAUSE	REMEDY
<p style="text-align: center;">C</p> <p>The brake will not hold a load with the control lever in neutral.</p>	<ol style="list-style-type: none"> 1. Excessive system back pressure acting on the brake release port. 2. Friction brake will not hold due to worn or damaged brake discs. 3. Brake clutch is slipping. 	<p>Same as remedy for Trouble B2.</p> <p>Same as remedy for Trouble A2.</p> <p>Improper planetary gear oil may cause the brake clutch to slip. Drain old gear oil and flush hoist with solvent. Thoroughly drain solvent and refill hoist with recommended planetary gear oil listed in "Preventive Maintenance".</p> <p>Brake clutch may be damaged or worn. Disassemble and inspect brake clutch as described in "Brake Clutch Service".</p>
<p style="text-align: center;">D</p> <p>The hoist will not hoist the rated load.</p>	<ol style="list-style-type: none"> 1. The hoist may be mounted on an uneven or flexible surface which causes distortion of the hoist base and binding of the gear train. Binding in the gear train will absorb horsepower needed to hoist the rated load and cause heat. 2. System relief valve may be set too low. Relief valve needs adjustment or repair. 3. Be certain hydraulic system temperature is not more than 180°F (82° C). Excessive hydraulic oil temperatures increase motor internal leakage and reduce motor performance. 4. Hoist line pull rating is based on 1st layer of wire rope. 5. Rigging and sheaves not operating efficiently. 	<p>Reinforce mounting surface.</p> <p>If necessary, use shim stock to level hoist. Refer to "Hoist Installation".</p> <p>First loosen, then evenly retighten all hoist mounting bolts to recommended torque.</p> <p>Check relief pressure as follows:</p> <ol style="list-style-type: none"> A. Install an accurate 0-4000 psi (28,000 kPa) gauge into the inlet port of the brake valve. B. Apply a stall pull load on the hoist while monitoring pressure. C. Compare gauge reading to hoist specifications. Adjust relief valve as required. <p>NOTE: If pressure does not increase in proportion to adjustment, relief valve may be contaminated or worn out. In either case, the relief valve may require disassembly or replacement.</p> <p>Same as remedies for Trouble D1 & D2.</p> <p>Same as remedies for Trouble E2.</p> <p>Refer to hoist performance charts for additional information.</p> <p>Perform rigging service as recommended by crane manufacturer.</p>

TROUBLE	PROBABLE CAUSE	REMEDY
<p>E The hoist runs hot.</p>	<ol style="list-style-type: none"> 1. Same as D1. 2. Be certain that the hydraulic system temperature is not more than 180°F (82°C). Excessive hydraulic oil temperatures may be caused by: <ol style="list-style-type: none"> A. Plugged heat exchanger. B. Too low or too high oil level in hydraulic reservoir. C. Same as D2. D. Hydraulic pump not operating efficiently. 3. Excessively worn or damaged internal hoist parts. 	<p>Same as remedies for Trouble D1.</p> <p>Thoroughly clean exterior and flush interior. Fill/drain to proper level.</p> <p>Same as remedies for Trouble D2.</p> <p>Prime mover low on horsepower or R.P.M. Tune/adjust prime mover.</p> <p>Check suction line for damage.</p> <p>If pump is belt driven, belts are slipping. Replace/tighten belts.</p> <p>Pump worn. Replace pump.</p> <p>Disassemble hoist to inspect/replace worn parts.</p>
<p>F Hoist “chatters” while raising rated load.</p>	<ol style="list-style-type: none"> 1. Same as D2. 2. Hydraulic oil flow to motor may be too low. 3. Controls being operated too quickly. 	<p>Same as remedies for Trouble D2.</p> <p>Same as remedies for Trouble E2.</p> <p>Conduct operator training as required.</p>
<p>G The wire rope does not spool smoothly on the drum.</p>	<ol style="list-style-type: none"> 1. The hoist may be mounted too close to the main sheave, causing the fleet angle to be more than 1½ degrees. 2. The hoist may not be mounted perpendicular to an imaginary line between the center of the cable drum and the first sheave. 3. Could possibly be using the wrong lay rope. There is a distinct advantage in applying rope of the proper direction of lay. When the load is slacked off, the several coils on the drum will stay closer together and maintain an even layer. If rope of improper lay is used, the coils will spread apart each time the load is removed. Then, when winding is resumed, the rope has a tendency to criss-cross and overlap on the drum. The result is apt to be a flattened and crushed rope. 4. The hoist may have been overloaded, causing permanent set in the wire rope. 	<p>Check mounting distance and fleet angle. Reposition hoist as required.</p> <p>Refer to “Hoist Installation”.</p> <p>Consult wire rope manufacturer for recommendation of wire rope that best suits your application.</p> <p>Replace wire rope and conduct operator/rigger training as required.</p>

SERVICE PRECAUTIONS

Before any part is removed from the hoist or drive gearbox, all service instructions should be read and understood.

Work in a clean, dust free area as cleanliness is of utmost importance when servicing hydraulic equipment.

Inspect all replacement parts, prior to installation, to detect any damage which might have occurred in shipment.

Use only genuine BRADEN replacement parts for optimum results. Never re-use expendable parts such as O-rings and oil seals.

Inspect all machined surfaces for excessive wear or damage before reassembly operations are begun.

Lubricate all O-rings and oil seals with gear oil prior to installation.

Lubricate all bearings with an oil soluble grease prior to assembly.

Use a sealing compound on the outside surface of oil seals and a light coat of thread sealing compound on pipe threads. Avoid getting sealing compound inside parts or passages which conduct oil.

Before beginning to disassemble the hoist or drive gearbox, remove the wire rope, drain the oil and clean the outside surfaces to avoid contaminating gears and bearings.

Item numbers shown in service procedures are referenced to the exploded view drawing in the center of this manual.

MAIN COMPONENTS

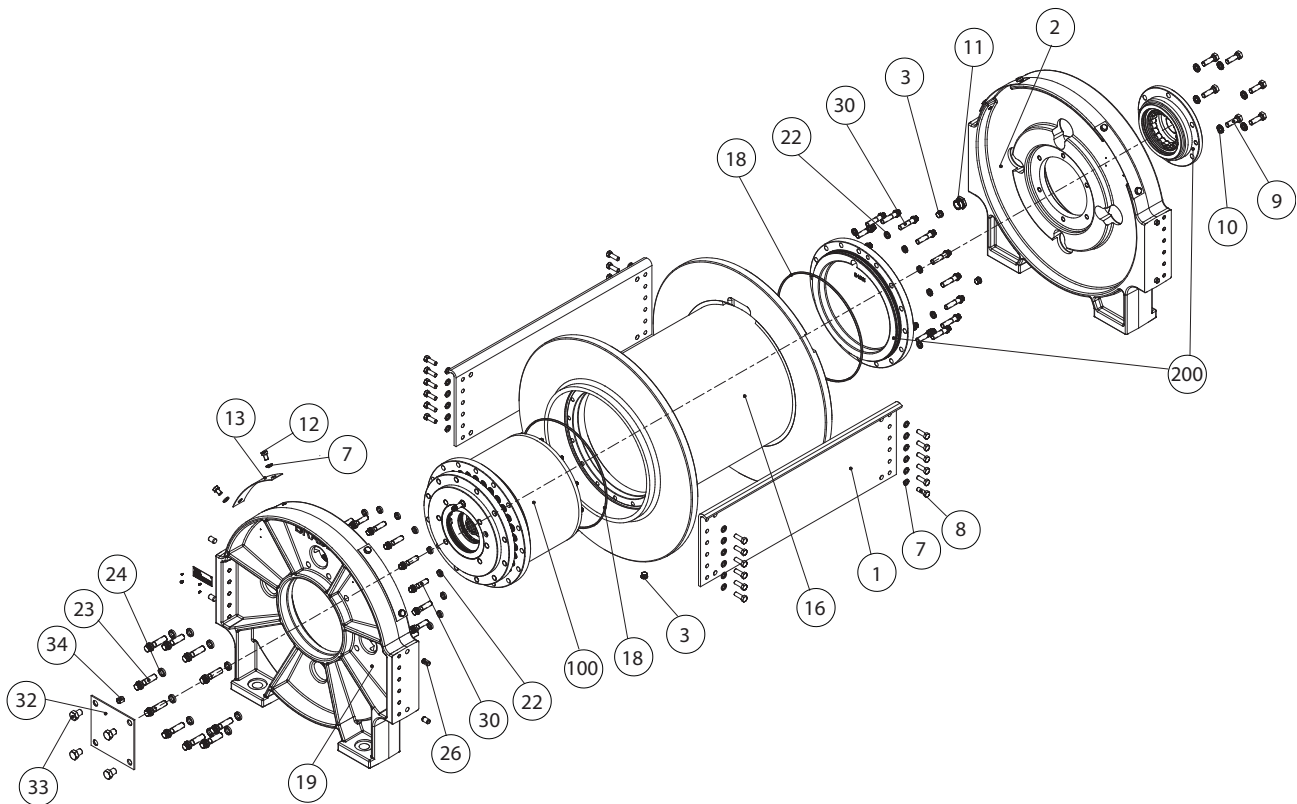

ITEM	DESCRIPTION	QTY
1	TIE PLATE	2
2	SUPPORT END PLATE	1
3	PLUG	3
7	LOCKWASHER	32
8	CAPSCREW	24
9	CAPSCREW	8
10	LOCKWASHER	8
11	SIGHT GAUGE	1
12	CAPSCREW	8
13	GUARD PLATE	4
16	CABLE DRUM	1
18	O-RING	2

ITEM	DESCRIPTION	QTY
19	MOTOR END PLATE	1
22	LOCKWASHER	32
23	CAPSCREW	10
24	LOCKWASHER	10
26	DOWEL PIN	8
30	CAPSCREW	32
33	CAPSCREW	4
34	FITTING	1
100	HOIST DRIVE GEARBOX	1
200	DRUM SUPPORT ASSEMBLY	1
400	CABLE CLAMP GROUP	1

HOIST DISASSEMBLY

⚠ WARNING ⚠

The hoist weighs 2900 lbs (1315 kg) to 3900 lbs (1770 kg) depending on model. Ensure the hoist and rigging are rated for this weight. Using a hoist or rigging with insufficient rating may result in death or personnel injury.

1. Stand the hoist on the end opposite the motor. Remove the hydraulic hose that connects the brake valve and motor to the brake release port. Remove the four (4) capscrews securing the motor to the hoist and lift off the motor/brake valve assembly. Remove and discard the O-ring installed on the outside of the motor pilot.

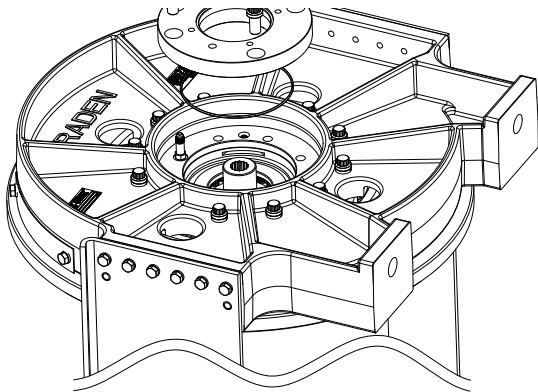

2. Remove the four (4) capscrews from the motor adapter and remove the motor adapter on SAE "C" motor only (item 40) from the drive gearbox. Remove and discard the O-ring (item 38) from the motor adapter.

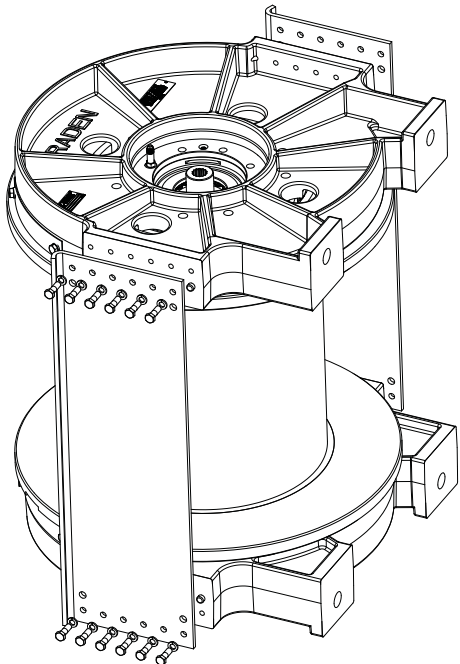

3. Remove the twenty four (24) capscrews and lockwashers securing the tie plates (item 1) to both end brackets and remove the tie plates. The tie plates have two dowel pins in each end and may have to be lightly

tapped or pried from the end brackets. Install four large c-clamps around the drum support end bracket (item 2) and the drum flange. This will prevent the end bracket and drum from separating when the motor end bracket and hoist drive are removed.

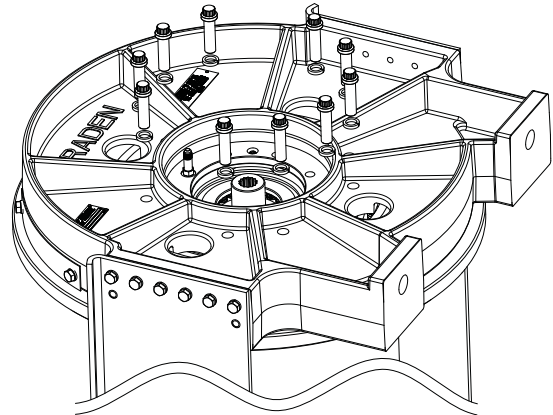

4. Remove the ten (10) 12 pt. capscrews (item 23) and lockwashers (item 24) securing the end bracket (item 19) to the gearbox. Use overhead hoist/chain to support end bracket/drum during tie plate removal.

⚠ WARNING ⚠

The hoist end-plate weighs 315 lbs (143 kg). Ensure the hoist and rigging are rated for this weight. Using a hoist or rigging with insufficient rating may result in death or personnel injury.

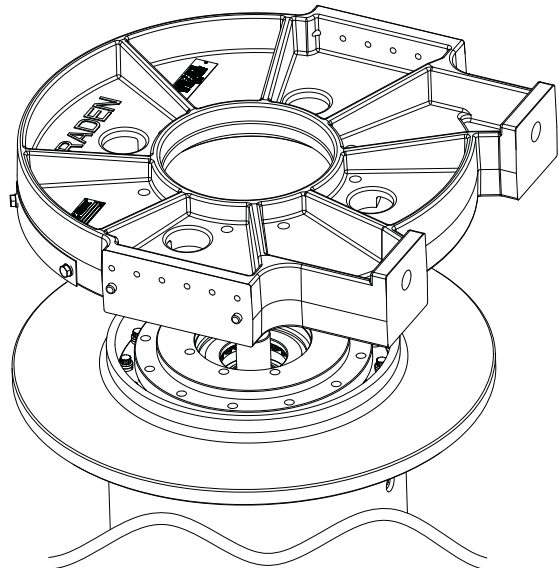

5. Lift the motor end bracket (item 25) from the drum/drive assembly.



Authorized Distributor:
Pacific Marine & Industrial
www.pacificmarine.net
info@pacificmarine.net

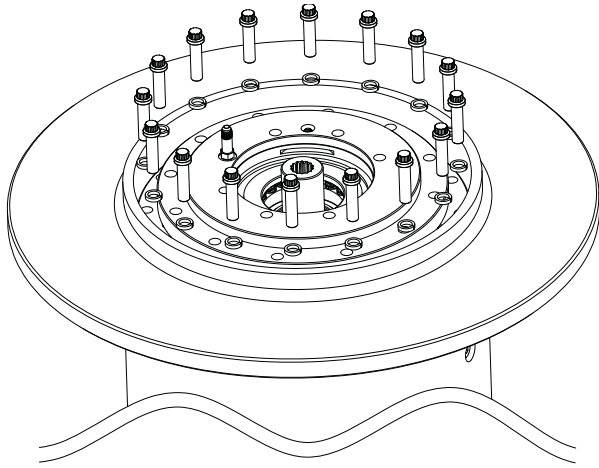

6. Remove the 12 point capscrews and lockwashers (items 30 & 22) that secure the gearbox to the hoist drum.

⚠ WARNING ⚠

The hoist drive weighs 565 lbs (256 kg). Ensure the hoist and rigging are rated for this weight. Using a hoist or rigging with insufficient rating may result in death or personnel injury.

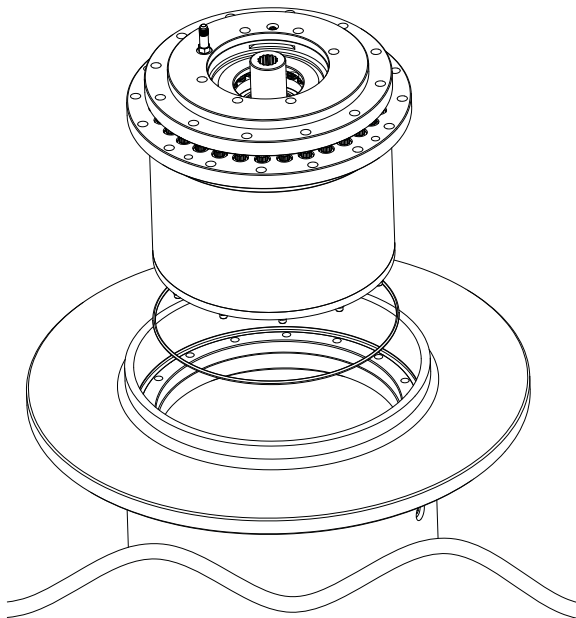

7. Lift the hoist drive gearbox out of the drum using two (2) 3/4 NC eye bolts spaced 180° apart as lifting lugs. Refer to Hoist Drive/Gearbox Service section for further disassembly of hoist drive



Authorized Distributor:
Pacific Marine & Industrial
www.pacificmarine.net
info@pacificmarine.net

HOIST ASSEMBLY

NOTE: Apply Loctite Marine Grade Anti-seize compound to all external fasteners before installation. These fasteners are items 8, 9, 12, 23, and 30 shown in the drawing on page 16, and the motor flange capscrew.

NOTE: A 5/8 inch and 3/4 inch 12 point 3/4 inch drive socket for the 12 point capscrews is needed to service the hoist.

5/8 socket part numbers – Snap-On IMD202A, Proto J07510T

3/4 socket part numbers – Snap-On IMD242A, Proto J07512T

The hoist drive subassembly must be assembled before following this procedure.

1. If drum support (5) was removed, install the o-ring (18) on the drum support and install the drum support in the hoist drum using lockwashers and capscrews. Torque the capscrews using a crisscross pattern to $250 \pm 15 \text{ lb}\cdot\text{ft}$ ($339 \pm 20 \text{ N}\cdot\text{m}$). Note: A 5/8 inch 12 point 3/4 inch drive socket for the 12 point capscrews is needed. Snap-On and Proto part numbers for this socket are given above.
2. Install the inner race of bearing (3) onto drum support (5) and secure in place with retaining ring (6).
3. Pack the bearing (3) rollers and outer hub (1) with NLGI #2 EP grease with a Lithium complex base that meets or exceeds NLGI GC or GC-LB specifications. Install the bearing outer race and rollers (3) in the outer hub (1).
4. Install a new o-ring (9) against the outer race of the bearing.
5. Install the seal (7) in seal container (8) as shown below. Install the seal container and seal into outer hub and secure in place with retaining ring (2).

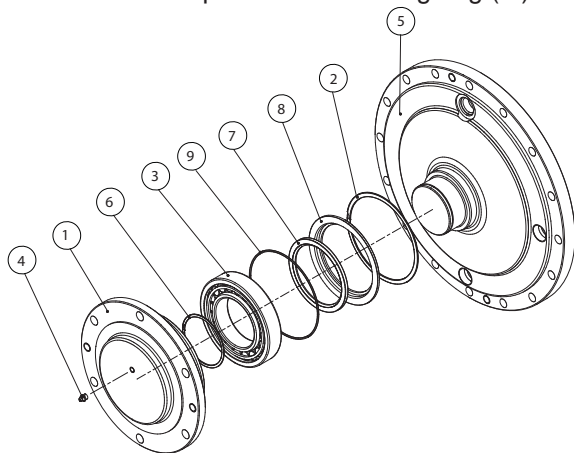

6. Secure outer hub with bearing and seal container in place on the hoist side plate using lockwashers (10) and capscrews (9). The outer hub should be positioned so that the grease fitting is at the 12 o'clock position with the hoist mounting feet setting on the ground. Torque capscrew (9) to the torque chart value given in this manual for 5/8" bolts.

7. Set the side-plate with outer hub installed and the drum side facing up on a surface capable of supporting assembled hoist weight (up to 4000 lbs or 1815 Kg depending on hoist drum).

⚠ WARNING ⚠

The hoist drum weighs 1000 to 1500 lbs (455 to 680 kg). Ensure the hoist and rigging are rated for this weight. Using a hoist or rigging with insufficient rating may result in death or personnel injury.

8. Grease bearing and seal surfaces on the drum support and carefully lower the drum onto the outer hub bearing rollers and ensure it is properly seated.

⚠ WARNING ⚠

The hoist drive weighs 565 lbs (256 kg). Ensure the hoist and rigging are rated for this weight. Using a hoist or rigging with insufficient rating may result in death or personnel injury.

9. Install 2 eye-bolts in the hoist drive assembly 180 degrees apart. Lift the hoist drive and while it is suspended, install a new O-ring (18) under the lower flange of the drive and grease lightly. Carefully set the hoist drive into the drum aligning the holes in the drum with those in the bottom flange of the drive.
10. Install capscrews (30) and lockwashers (22) that secure the hoist drive to the drum and torque to $250 \pm 15 \text{ lb}\cdot\text{ft}$ ($339 \pm 20 \text{ N}\cdot\text{m}$).

⚠ WARNING ⚠

The hoist end-plate weighs 315 lbs (143 kg). Ensure the hoist and rigging are rated for this weight. Using a hoist or rigging with insufficient rating may result in death or personnel injury.

11. Install the motor end plate (19) onto the hoist drive. Orient the end plate so that the brake release port is at the 12 o'clock position if the hoist is a standard unit.
12. Install the ten capscrews (23) and lockwashers (24) which secure the end plate to the hoist drive.
13. Install the two tie plates (1) between the two end plates using the dowels in the end plates to align and position the tie plates. Install the twenty-four capscrews (8) and lockwashers (7) securing the tie plates to the end plates.
14. Torque the capscrews (23) securing the end plate (19) to the hoist drive to $400 \pm 15 \text{ lb}\cdot\text{ft}$ ($540 \pm 50 \text{ N}\cdot\text{m}$).
15. Torque the capscrews (8) securing the tie plates the end plates to the value listed on the torque chart for 1/2 inch Grade 8 capscrews.

16. Install a new O-ring on the hydraulic motor pilot for an SAE "C" flange motor, or in the motor adapter for the SAE "D" flange motor. Install the hydraulic motor onto the motor adapter engaging the motor splines with the overrunning clutch inner race. Install the four capscrews and lockwashers which secure the motor to the motor adapter. Connect the brake release hose to the brake release port on the hoist drive.

17. Fill bearing cavity through the grease fitting at the drum support end with a NLGI #2 EP grease with a Lithium complex base that meets or exceeds NLGI GC or GC-LB specifications.

DRUM SUPPORT END BRACKET SERVICE

If the hoist disassembly procedure has been followed to this point, remove the c-clamps installed in step 4. If only this end of the hoist is being serviced, support the hoist on the motor end bracket and remove the twelve (12) capscrews and lockwashers securing the end of both tie plates (item 1), to the drum support end bracket (item 2). Loosen the twelve (12) capscrews on the other end of both tie plates just enough to allow the tie plates to be pried free of the dowel pins in the drum support end bracket.

⚠ WARNING ⚠

The hoist end-plate weighs 315 lbs (143 kg). Ensure the hoist and rigging are rated for this weight. Using a hoist or rigging with insufficient rating may result in death or personnel injury.

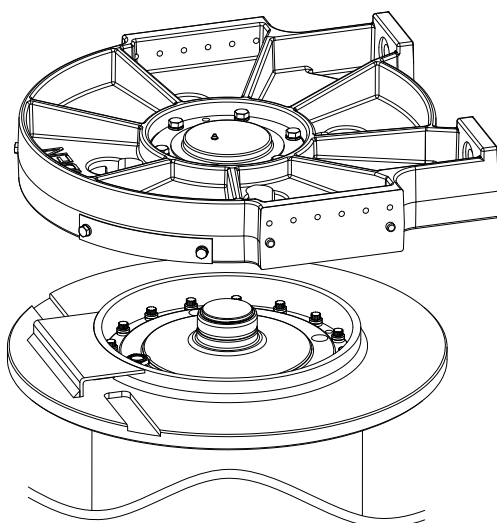

1. Lift the support end bracket from the drum. NOTE: If the hoist disassembly procedure was followed and the drum is on top of the end bracket, lift the drum from the support end bracket.

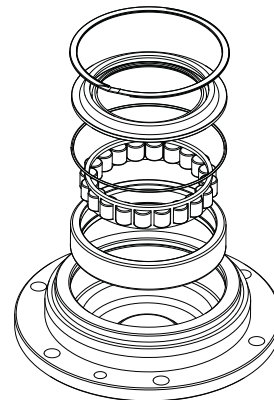

2. The outer hub (item 1) is in the end bracket, and the drum support (item 3) is in the drum. Remove the retaining ring (item 2) and the seal carrier and seal (items 6 & 7). Remove and discard O-ring (item 9). Remove the seal from the seal carrier and discard.

Thoroughly clean all parts and inspect for damage and wear. The bearing rollers should not exhibit any irregularities. If the rollers show any sign of spalling, corrosion, discoloration, material displacement or abnormal wear, the bearing should be replaced.

Apply a non-hardening sealant to the outside diameter of a new seal. Install the seal into the seal carrier as shown above. Install a new O-ring against the outer race of the bearing and install the seal carrier into the bearing carrier/end cap. Install a new retaining ring into the groove in the end cap. Liberally pack the bearing and end cap with grease. The end bracket can now be placed on the drum, or the drum placed on the end bracket, depending on your method of assembly.

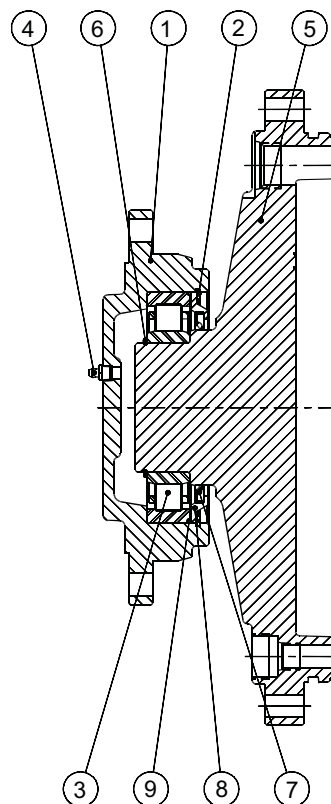

THIS PAGE INTENTIONALLY LEFT BLANK

HOIST SERVICE

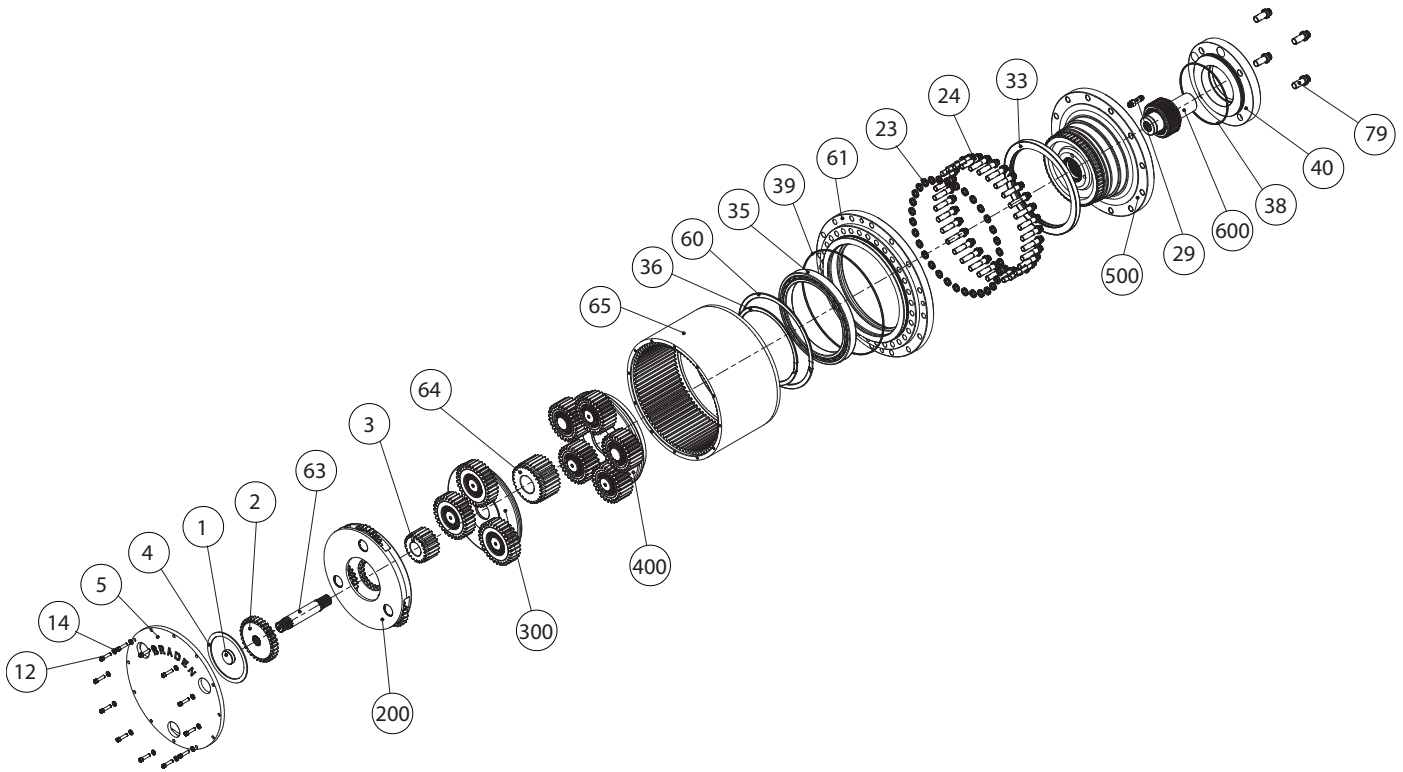

Item No	Description	Qty
1	THRUST BUTTON	1
2	PRIMARY SUN GEAR	1
3	INTERMEDIATE SUN GEAR	1
4	WASHER, THRUST	1
5	COVER	1
12	CAPSCREW	12
14	LOCKWASHER	12
23	LOCKWASHER	32
24	CAPSCREW	32
29	ADAPTER, LONG	1
33	LIP SEAL	1
35	BEARING	1
36	RETAINING RING	1
38	O-RING	1

Item No	Description	Qty
39	O-RING	1
40	MOTOR ADAPTER	1
60	RETAINING RING	1
61	BEARING CARRIER	1
63	SHAFT	1
64	FINAL SUN GEAR	1
65	RING GEAR	1
79	CAPSCREW	4
200	PRIMARY CARRIER ASSY	1
300	INTERMEDIATE CARRIER ASSY	1
400	FINAL CARRIER ASSY	1
500	BRAKE CYLINDER ASSY	1
600	OVER RUNNING CLUTCH ASSY	1



Authorized Distributor:
Pacific Marine & Industrial
www.pacificmarine.net
info@pacificmarine.net

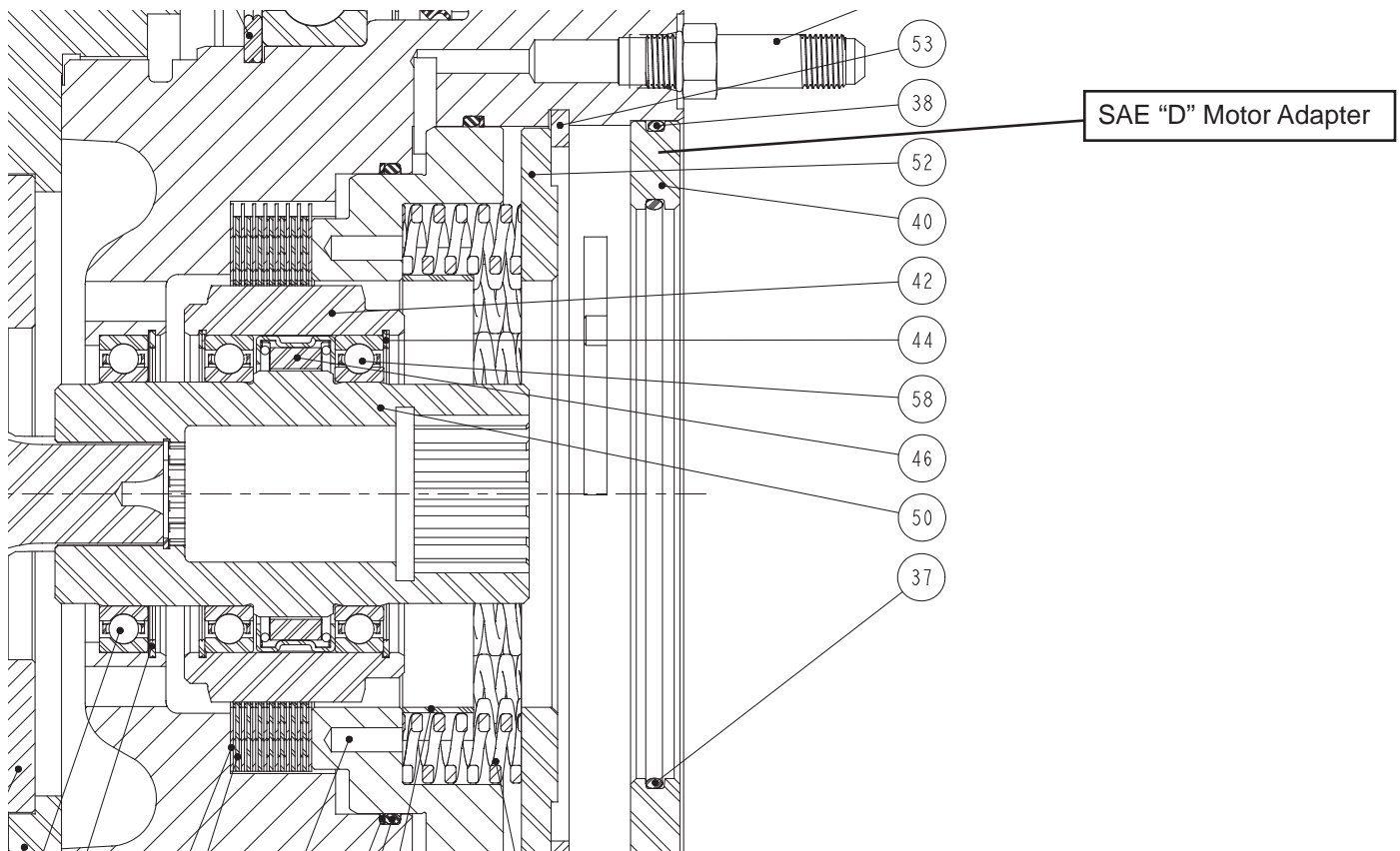

DISASSEMBLY

⚠ WARNING ⚠

The hoist drive weighs 565 lbs (256 kg). Ensure the hoist and rigging are rated for this weight. Using a hoist or rigging with insufficient rating may result in death or personnel injury.

1. Set the hoist drive assembly on a work bench rated for the weight of the drive. Position the hoist drive so the motor side is down. For SAE "C" motor flange units, place spacer blocks under the brake cylinder so the sprag clutch inner race does not hit the work bench.
2. Remove the capscrews (12) and lockwashers (14) which secure the cover (5) to the ring gear (65) and remove the cover.
3. Remove the thrust button (1) and the thrust washer (4). Remove the primary planet carrier assembly and primary sun gear (2) and the gear shaft (63).
4. Remove the intermediate sun gear (3) and the intermediate planet carrier assembly (300).
5. Remove the final sun gear (64) and the final planet carrier assembly (400).
6. Remove the retaining ring (36) which retains the brake cylinder to the bearing carrier (61).
7. Place 5/16 NC eye-bolts 180 degrees apart in the ring gear tapped holes and carefully lift the ring gear off of the brake cylinder. Lift straight up using an overhead hoist and rigging connected to the eye-bolts in the ring gear.
8. If the bearing carrier (61) is to be removed from the ring gear (65), remove the capscrews (24) and lockwashers (23) which secure the bearing carrier (61) to the ring gear (65). Remove O-ring (39).
9. Support the brake cylinder assembly and lightly tap the overrunning clutch inner race with a soft mallet to unseat from the bearing (58) and remove overrunning clutch from the brake cylinder. For overrunning clutch service, refer to Overrunning Clutch Service section of this manual.
10. Remove retaining ring (60) from the bearing carrier and remove the bearing carrier seal (33). Remove the bearing (35) from the bearing carrier (61) and inspect the bearing for signs of irregular wear and ensure the bearing rollers rotating smoothly. Inspect the bearing carrier surfaces as described below.
11. Refer to planet carrier, overrunning clutch, and brake cylinder disassembly procedures for further disassembly of components.

Thoroughly clean all parts and inspect for damage. Inspect all machined surfaces for irregular wear. Inspect the ring gear and planet gear teeth for nicks, pitting, and any signs of wear. Inspect the gear cover (5) for signs of abnormal wear. Inspect the thrust washers (1 and 4) for wear or damage and replace as required.

ASSEMBLY

Before beginning assembly of the hoist drive, assemble the brake cylinder assembly, overrunning clutch assembly, primary planet carrier assembly, intermediate planet carrier assembly, and final planet carrier assembly following procedures in this manual.

1. Clean all metal parts in solvent and allow to dry.
2. Place bearing carrier (61) on clean work bench. Apply Loctite Aviation Gasket Sealant or equivalent non-hardening sealant to outside diameter of seal and install seal (33) in bearing carrier (61).
3. Install bearing (35) in bearing carrier (34). Install retaining ring (60) above bearing (35).
4. If the bearing carrier (61) was removed from the ring gear (65), install O-ring (39) in the bearing carrier groove and lubricate lightly with grease then set the bearing carrier onto the ring gear. Using marine grade anti-seize compound, install lockwashers (23) and capscrews (24) that fasten the bearing carrier (34) to the ring gear (65). Torque capscrews to $200 \pm 15 \text{ lb}\cdot\text{ft}$ ($271 \pm 20 \text{ N}\cdot\text{m}$) alternating capscrews across the ring gear.
5. Install the overrunning clutch assembly into the brake cylinder assembly. Ensure the brake discs are aligned before trying to seat the overrunning clutch inner race onto the bearing in the brake cylinder. The brake cylinder may need to be pressurized with a hand pump to align the brake discs.
6. Install O-ring (38) on motor adapter (40) and lightly grease. Install motor adapter onto the brake cylinder. For the SAE "C" motor flange, install and torque the four capscrews (79) which secure the motor adapter to the brake cylinder.
7. Set the brake cylinder assembly on the workbench with the motor end down. Place spacer blocks under the brake cylinder so the overrunning clutch inner race does not contact the work bench (needed for SAE "C" flange motor if the motor adapter is not installed). Apply a light coat of grease to the bearing and seal surfaces on the brake cylinder and the inner race of the bearing and seal in the bearing carrier.
8. Use 5/16 eye-bolts 180 degrees apart in the ring gear cover holes to lower the bearing carrier and ring gear assembly onto brake cylinder taking care not to damage the bearing carrier seal (33). Install retaining ring (36) in brake cylinder.
9. Lower final planet carrier assembly (400) into ring gear ensuring teeth on planet carrier engage with teeth on ring gear. Install final sun gear (64) in between final planet gears.
10. Install intermediate planet carrier assembly (300) in ring gear engaging intermediate planet carrier teeth with final sun gear teeth (64). Install intermediate sun gear (3) between intermediate planet gears.
11. Install primary planet carrier assembly (200) in ring gear and ensure primary carrier gear teeth engage with intermediate sun gear (3) teeth.
12. Install gear shaft (63) through the sun gears and into the overrunning clutch inner race splines. Install primary sun gear (2) between primary gear teeth and gear shaft (63) splines.
13. Apply multipurpose grease to the thrust button (1) and the thrust washer (4) to hold in place in the cover (5). Ensure grease will hold thrust button and thrust washer in place and lower the cover (5) onto the ring gear.
14. Align cover (5) holes with ring gear threaded holes. Apply Loctite 242 to capscrews (12) and install with lockwashers (14) to secure the cover (5) to the ring gear (65). Torque to $25 \pm 5 \text{ lb}\cdot\text{ft}$ ($34 \pm 7 \text{ N}\cdot\text{m}$).



Authorized Distributor:
Pacific Marine & Industrial
www.pacificmarine.net
info@pacificmarine.net

THIS PAGE INTENTIONALLY LEFT BLANK

BRAKE CYLINDER SERVICE

DISASSEMBLY

⚠ WARNING ⚠

The force of the brake springs can cause personal injury or death if safety procedures are not followed. Review safety requirements for using a hydraulic press before disassembly of the brake cylinder.

1. Use a special compressor tool to compress the springs. If a hydraulic press is available, only part "A" of the spring compressor tool is required. Tighten the nut above part "A" or if using a press apply hydraulic pressure to slightly compress the springs and relieve the force on the retaining ring (53). Carefully remove the retaining ring (53) with retaining ring pliers. Slowly unscrew the nut above part "A" until spring force is no longer acting on the spring stop (52); if using a hydraulic press, release the force on the brake springs. Remove the compressor tool.
2. Remove the spring stop (52), springs (55), and spring spacer (62) from the brake cylinder.
3. Remove the brake piston (59). Remove and discard both sets of o-rings and back-up rings (27, 28, 30, and 31).
4. Remove the friction plates (25) and brake plates (26).
5. Remove the retaining ring (44) and bearing (58).
6. Remove relief valve (54) and clean in solvent. The relief valve must be free of contamination and paint for proper operation.

Clean and Inspect Parts

Thoroughly clean and inspect all parts, paying attention to the sealing surfaces of the brake piston. Place each friction disk on a flat surface and check for distortion with a straight edge. Friction material should appear even across the entire surface and the groove pattern should be visible. Replace friction disks if splines are worn to a point, disk is distorted, friction material is worn unevenly or groove pattern is no longer visible. Place each steel brake plate on a flat surface and check for distortion with a straight edge. Check surface for signs of material transfer or heat. Replace steel disks if splines are worn to a point, disk is distorted or heat discolored.

Check the brake release passage to be sure it is clean and completely open. Inspect bearing for signs of damage or excessive wear.

The minimum spring free length is 1.50 inches (38.1 mm). If any spring free length is below the minimum, all of the springs must be replaced.

ASSEMBLY

1. Clean and inspect parts as described in the Disassembly procedure.
2. Install bearing (58) in brake cylinder and install retaining ring (44) in brake cylinder groove above bearing.
3. There are 7 friction discs (25) and 8 steel brake discs (26) in the standard CH400B brake, but units with SPL (special) in the model number may have a different number. Coat the surface of the friction discs (25) with hoist gear oil. Starting with a steel disc (26) alternately install steel and friction discs in the brake cylinder until all 8 steel discs and 7 friction discs are installed.
4. Install back-up ring (27) and o-ring (28) in small diameter brake cylinder groove. Install back-up ring (31) and o-ring (30) in large diameter brake cylinder groove. The o-rings are always closest to the high pressure side. Apply a light coat of grease to both o-rings and back-up rings and let them set a few minutes to take shape in the groove before proceeding to the next step.
5. Lightly grease the o-ring sealing surfaces on the brake piston (59). Ensure the o-rings and back-up rings are seated in the brake cylinder grooves and then gently push the brake piston into the brake cylinder. If the piston cannot be pushed in by hand, remove and check the condition of the o-rings before proceeding.
6. Install the spring spacer (62) into the piston and install the springs (55) in the spring spacer. There are 18 springs in the standard brake but units with SPL (special), in the model number may have a different number.
7. Set the spring stop (52) on top of springs. The machined step in the spring stop should be toward the motor side of the brake cylinder – the retaining ring will seat against the machined step in the spring stop.

⚠ WARNING ⚠

The force of the brake springs can cause personal injury or death if safety procedures are not followed. Review safety requirements for using a hydraulic press before disassembly of the brake cylinder.

8. Use a hydraulic press or compression tool to compress the springs and use retaining ring pliers to install the retaining ring (53) into the brake cylinder groove. Carefully release the force on the springs while ensuring the retaining ring remains properly seated in the groove.
9. Apply a light coat of Teflon sealant to the threads of relief valve (54) and install in brake cylinder.

Brake Cylinder Pressure Test

Connect a hydraulic hand pump with an accurate gauge and shut-off valve to the brake release port. Apply 500 psi (3,450 kPa) to the brake. Close the shut-off valve and let stand for five (5) minutes. If there is any loss of pressure, the brake cylinder should be disassembled for inspection of the sealing surfaces and O-rings.

WHILE PRESSURE IS APPLIED AND THE BRAKE IS RELEASED, install the sprag clutch assembly. Rotate the sprag clutch back and forth to align the splines in all brake discs before pushing into the brake cylinder bearing. Leave the sprag clutch installed if proceeding with assembly of the hoist drive.

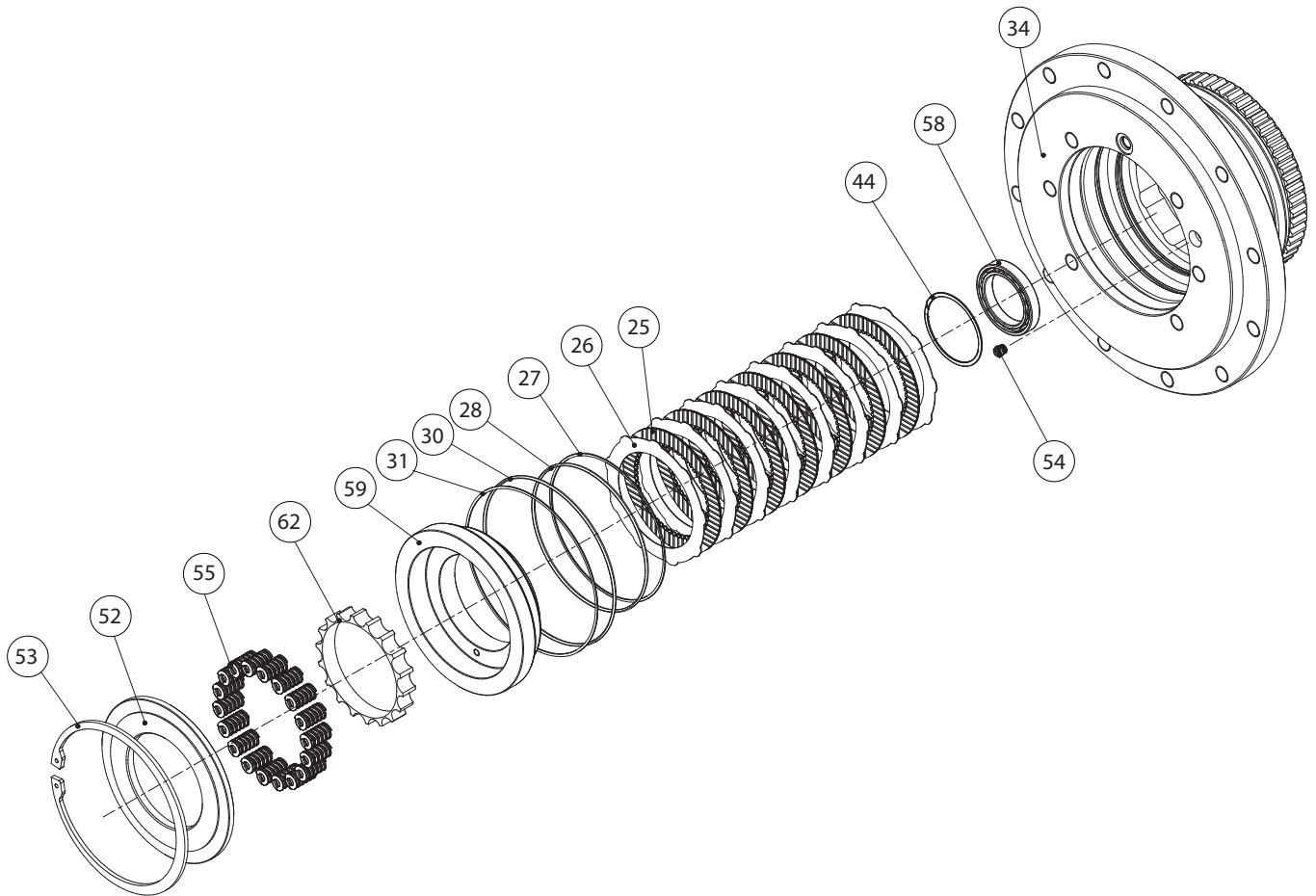

Item No	Description	Qty
25	FRICITION DISC	7
26	BRAKE DISC	8
27	BACK-UP RING	1
28	O-RING	1
30	O-RING	1
31	BACK-UP RING	1
34	MOTOR SUPPORT	1
52	SPRING STOP	1

Item No	Description	Qty
53	RETAINING RING	1
55	SPRING	18
59	BRAKE PISTON	1
62	SPRING SPACER	1
44	RETAINING RING	1
58	BALL BEARING	1
54	RELIEF VALVE	1



Authorized Distributor:
Pacific Marine & Industrial
www.pacificmarine.net
info@pacificmarine.net

OVER-RUNNING CLUTCH SERVICE

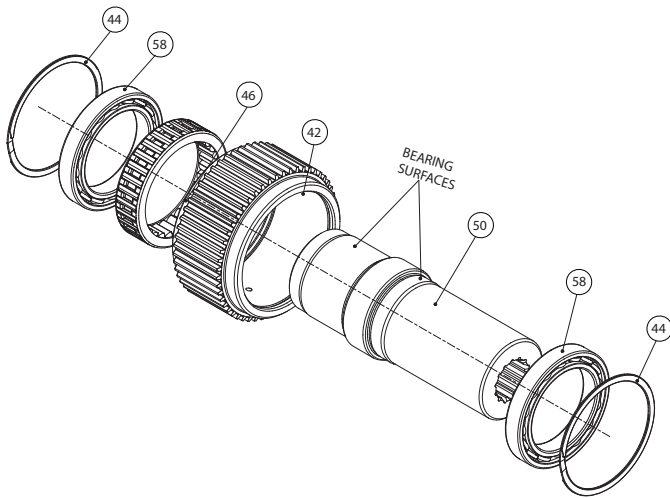

NOTE: Outer race (item 42), Inner race (item 50) and Over-running clutch (item 46) are NOT SOLD individually as replacement parts. If any of these parts require replacement, the entire over-running clutch assembly must be replaced. Carefully note the relative orientation between the inner and outer races, and the direction of free rotation of the inner race. The clutch MUST be re-assembled correctly for proper hoist operation.

⚠ WARNING ⚠

The polished surfaces of the inner and outer race and the over-running cams must be perfectly smooth to insure positive engagement of the clutch. The slightest defect may reduce clutch effectiveness, which may lead to loss of load control and result in property damage, injury or death. It is generally recommended to replace the entire clutch assembly if any component is defective. For these reasons, the over-running clutch assembly should be disassembled for inspection only if the hoist has exhibited any unusual operation that would point toward a clutch malfunction, or the over-running clutch assembly shows external signs of mechanical damage.

DISASSEMBLY

1. Remove one of the retaining rings (item 44) from the outer race (item 42). Push the inner race (item 50), bearings (item 58) and over-running clutch (item 46) through the outer race.
2. Use a small punch and hammer to tap one of the bearings (item 58) off of the inner race. The over-running clutch can now be removed from the inner race. Closely inspect the over-running clutch and the polished surfaces of the inner and outer race for wear, cracks, pitting, corrosion or mechanical damage. Closely inspect the bearings for any signs of damage, wear, corrosion, pitting or heat discoloration.

NOTE: Remove bearing from long end of inner race first.

ASSEMBLY

⚠ WARNING ⚠

Failure to assemble the over-running clutch assembly with all parts oriented correctly may result in reduced brake effectiveness, which may lead to loss of load control and result in property damage, injury or death.

1. If both bearings (item 58) have been removed from the inner race, install one of them now.
2. Install the over-running clutch onto the inner race. Rotate the inner race slightly to get the clutch started onto the inner race.
3. Install the other bearing onto the inner race.
4. The outer race should have one retaining ring (item 44) installed in one end. Carefully slide the inner race, with bearings and clutch, into the outer race. Install the other retaining ring into the outer race.

Shown below are the two types of clutch assemblies used in CH400B hoists. The drawings show each type properly assembled for standard rotation.

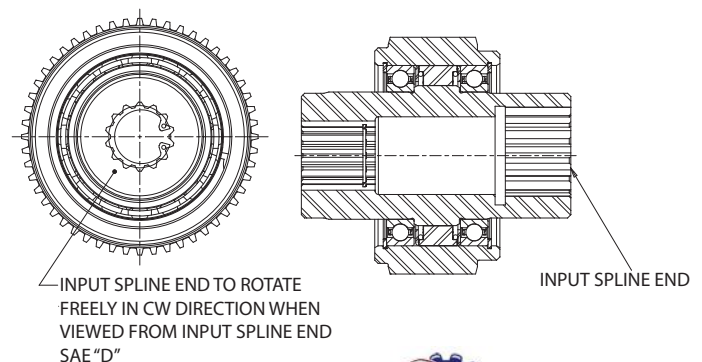
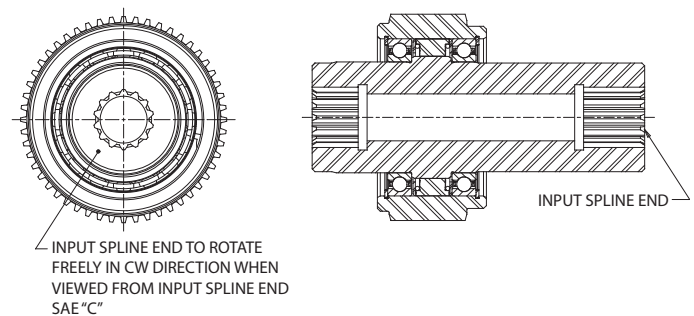

Authorized Distributor:
Pacific Marine & Industrial
www.pacificmarine.net
info@pacificmarine.net

PRIMARY PLANET CARRIER SERVICE

DISASSEMBLY

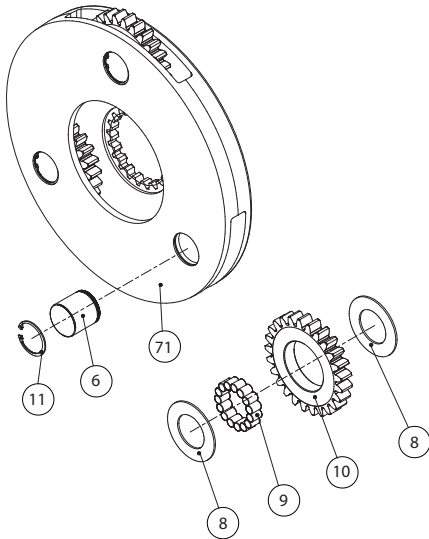

ITEM NO.	DESCRIPTION	QTY
6	PLANET PIN	3
8	THRUST WASHER	6
9	BEARING ROLLER	45
10	PLANET GEAR	3
11	RETAINING RING	3
71	PLANET CARRIER	1

1. Remove the retaining ring (11) from one of the planet carrier gears.

⚠ WARNING ⚠

Observe safety procedures when operating a hydraulic press. Failure to follow safety procedures can result in death or personal injury.

⚠ CAUTION ⚠

If the planet carrier is not properly supported or excessive force is applied to the planet pin, damage to the planet carrier can occur.

2. Use a press to drive the planet pin (6) knurl past the carrier. Place a tray or bucket under the press to catch any loose bearing rollers (10) that drop. If the planet pin (6) is supported after it clears the knurl surface, the bearing rollers will remain in place. Hold both thrust washers (8) against the gear (10) while sliding the planet pin (6) out of the gear then pull the gear from the carrier keeping the thrust washers against the gear.
3. Repeat the above steps for the remaining two planet gears.
4. Thoroughly clean all parts and inspect for damage and wear. The bearing rollers should exhibit no irregularities. If the rollers show any sign of spalling, corrosion, discoloration, material displacement or abnormal wear,

the bearing rollers should be replaced. The thrust washer contact areas should be free from any surface irregularities that may cause abrasion or friction. The planet gears (10) and planet pins (6) should be inspected for abnormal wear or pitting.

ASSEMBLY

The loose roller bearings can be difficult to keep in place during assembly. This procedure attempts to simplify this.

1. Clean and inspect parts as described in step 4 of the disassembly procedure.
2. Place planet gear (10) on clean workbench resting on the gear teeth. Coat bearing rollers (9) with grease and place in lower half of gear. Coat one thrust washer (8) with grease and place in position on planet gear. Slide planet pin (6) into planet gear and center. Grease remaining bearing rollers (9) and slide between planet gear (10) and planet pin (6). After all bearing rollers are in gear, grease remaining thrust washer (8) and slide over planet pin into position on gear to hold roller bearings in place.
3. Place planet carrier (71) on work bench with planet pin retaining ring groove facing up.
4. Hold planet pin in position with the thrust washers (8) against gear and lift gear so the planet pin is vertical. While holding washers in place, slide planet pin out of gear. Slide planet gear with washers into planet carrier (71) and align with the carrier opening. Slide planet pin - **knurled end first** - through planet carrier and gear until knurl seats against opposite side of the planet carrier.
5. Place planet carrier in hydraulic press and provide support around planet pin hole. Slowly press the knurled surface of the planet pin into carrier until retaining ring groove is visible. Install retaining ring (11).

⚠ WARNING ⚠

Observe safety procedures when operating a hydraulic press. Failure to follow safety procedures can result in death or personal injury.

⚠ CAUTION ⚠

If the planet carrier is not properly supported or excessive force is applied to the planet pin, damage to the planet carrier can occur.

6. Repeat procedure for remaining two planet gears.

INTERMEDIATE PLANET CARRIER SERVICE

DISASSEMBLY

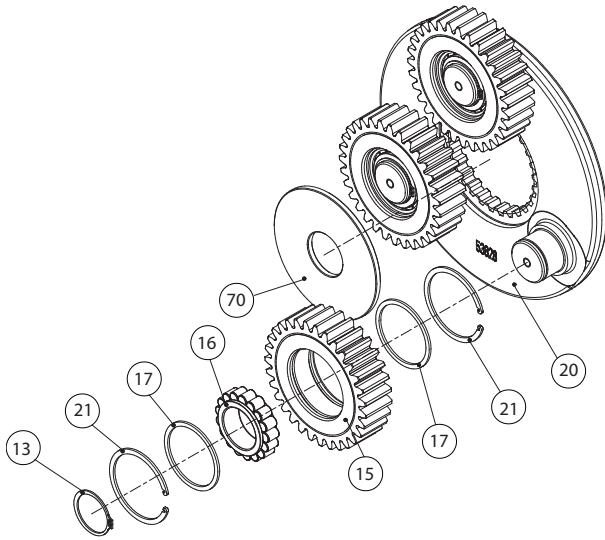

ITEM NO	DESCRIPTION	QTY
13	SNAP RING	3
15	PLANET GEAR	3
16	BEARING ROLLER	3
17	THRUST SPACER	6
20	PLANET CARRIER	1
21	RETAINING RING	6
70	THRUST SPACER	1

1. Remove the retaining ring (13) from one of the planet carrier posts.
2. Use a gear puller to pull the planet gear (15) off of the planet carrier post. If a gear puller is not available, two pry-bars positioned 180° apart can be used to pry the gear off of the planet carrier post, but care must be taken to ensure the pry-bar does not contact and damage the planet carrier post machined surface.
3. The loose rollers will scatter if dropped so take precautions to ensure they are captured during this step of disassembly. Remove the retaining ring (21) and thrust washer (17) and push the roller bearing out of the gear (15).
4. Repeat the above steps for the remaining two planet gears.
5. Thoroughly clean all parts and inspect for damage and wear. The bearing rollers and bearing race should exhibit no irregularities. If the rollers or race show any signs of spalling, corrosion, discoloration, material displacement or abnormal wear, the bearing rollers should be replaced. The thrust washer contact areas should be free from any surface irregularities that may cause abrasion or friction. The gears and planet pins should be inspected for abnormal wear or pitting.

ASSEMBLY

The loose roller bearings can be difficult to keep in place during assembly. This procedure attempts to simplify this.

1. Clean and inspect parts as described in step 4 of the disassembly procedure.
2. Place planet gear (15) on clean workbench. Install a thrust washer (17) and retaining ring (21) in one side of the planet gear. Set the bearing inner race near the planet gear and coat bearing rollers (9) with enough NLGI #2 grease to hold the bearing rollers in place on the inner race. A rubber band can be used to hold the bearing rollers on the inner race if needed; slide it off once the rollers enter the gear. Slide the bearing into the planet gear.
3. Install the remaining thrust washer (17) and then install remaining retaining ring (21) in gear.
4. Ensure the thrust spacer (70) is in place in the planet carrier before installing gears on the planet carrier posts.
5. Apply a light coat of grease the planet carrier bearing post and then slide the planet gear onto the planet carrier post.
6. Install the snap-ring (13) to secure the planet gear to the planet carrier.
7. Repeat procedure for remaining two planet gears.



Authorized Distributor:
Pacific Marine & Industrial
www.pacificmarine.net
info@pacificmarine.net

FINAL PLANET CARRIER SERVICE

DISASSEMBLY

ASSEMBLY

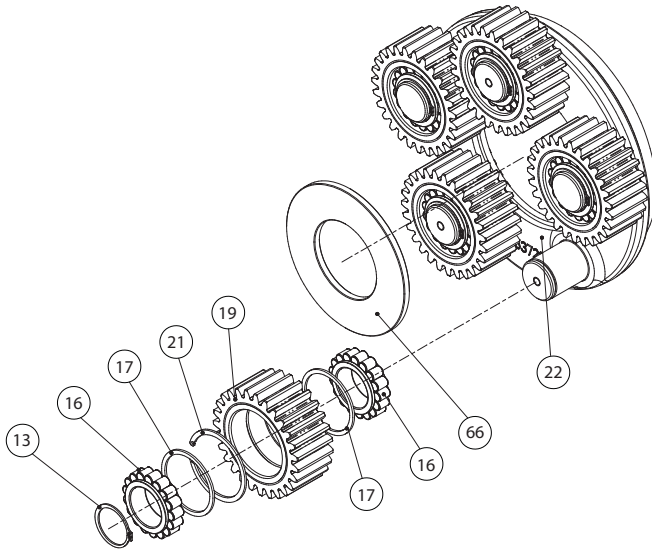

ITEM NO	DESCRIPTION	QTY
13	RETAINING RING	5
16	BEARING ROLLER	10
17	THRUST SPACER	10
19	PLANET GEAR	5
21	RETAINING RING	5
22	PLANET CARRIER	1
66	THRUST SPACER	1

1. Remove the retaining ring (13) from one of the planet carrier posts.
2. The loose rollers will scatter if dropped so take precautions to ensure they are captured during this step of disassembly. Use a gear puller to pull the planet gear (19) off of the planet carrier post. If a gear puller is not available, two pry-bars positioned 180° apart can be used to pry the gear off of the planet carrier post, but care must be taken to ensure the pry-bar does not contact and damage the planet carrier post.
3. Push the roller bearings out of the gear (19) and remove the retaining ring (21) and two thrust washers (17). Remove the thrust spacer (66).
4. Repeat the above steps for the remaining two planet gears.
5. Thoroughly clean all parts and inspect for damage and wear. The bearing rollers and bearing race should exhibit no irregularities. If the rollers or race show any signs of spalling, corrosion, discoloration, material displacement or abnormal wear, the bearing rollers should be replaced. The thrust washer contact areas should be free from any surface irregularities that may cause abrasion or friction. The gears and planet pins should be inspected for abnormal wear or pitting.

The loose roller bearings can be difficult to keep in place during assembly. This procedure attempts to simplify this.

1. Clean and inspect parts as described in step 4 of the disassembly procedure.
2. Ensure thrust spacer (66) is installed in the planet carrier (22) before installing the gears on the planet carrier posts.
3. Place planet gear (15) on clean workbench. Install retaining ring (21) in the center groove of planet gear and place one of the thrust washers (17) on the retaining ring.
4. Set the bearing inner race near the planet gear and coat bearing rollers (9) with enough grease to hold the bearing rollers in place on the inner race. A rubber band can be used to hold the bearing rollers on the inner race if needed; slide it off once the rollers enter the gear. Slide the bearing into the planet gear. Hold the rollers in place and turn the planet gear over. Set remaining thrust washer (17) on top of retaining ring (21) and repeat this assembly step for the second bearing set for this planet gear.
5. Apply a light coat of grease the planet carrier bearing post and then slide the planet gear onto the planet carrier post.
6. Install the snap-ring (13) to secure the planet gear to the planet carrier.
7. Repeat procedure for remaining planet gears.



Authorized Distributor:
Pacific Marine & Industrial
www.pacificmarine.net
info@pacificmarine.net

BRAKE VALVE SERVICE

Braden CH400B hoist is supplied with one of two Braden brake valves, depending on the hydraulic motor used. Both are reliable hydraulic valves with internal components manufactured to close tolerances. Due to these close tolerances, several individual parts are not available as replacement parts and are noted in the following parts list as NSS (not serviced separately).

Before disassembling the brake valve, be sure you have conducted all applicable troubleshooting operations and are certain the brake valve is causing the malfunction.

Thoroughly clean the outside surfaces of the valve and work in a clean dust free area, as cleanliness is of utmost importance when servicing hydraulic components.

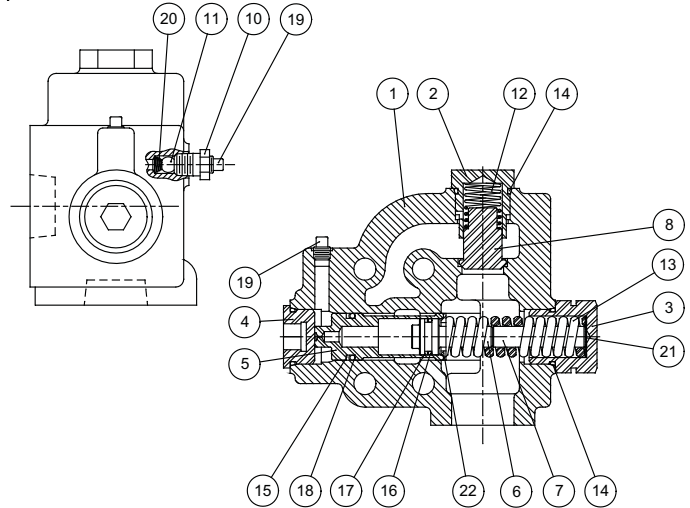

1 1/4 INCH BRAKE VALVE

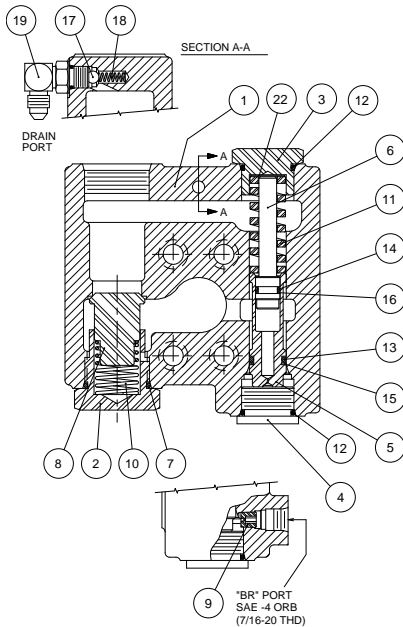

ITEM	DESCRIPTION	QTY.
1	Valve Housing	NSS
2	Check Valve Retainer	1
3	Spring Retainer	1
4	Plug	1
5	Main Piston	NSS
6	Damper Piston	NSS
7	Damper Piston Extension	1
8	Check Valve Poppett	NSS
10	Reducer	1
11	Check Ball	1
12	Check Valve Spring	1
13	Main Piston Spring	1
14	O-ring	1
15	Back-up Ring	1
16	O-ring	1
17	Back-up Ring	1
18	O-ring	1
19	Pipe Plug	1
20	Check Spring	1
21	Shim	1
22	Spring Seat	1

NSS- NOT SERVICED SEPARATELY - REPLACE COMPLETE VALVE ASSEMBLY

ITEM	DESCRIPTION	QTY.
1	Valve Housing	NSS
2	Check Valve Retainer	1
3	Spring Retainer	1
4	Plug	1
5	Spool	NSS
6	Damper Piston	NSS
7	O-ring	1
8	Check Valve Poppett	NSS
9	Pilot Orifice	1
10	Check Valve Spring	1
11	Spool Spring	1
12	O-ring	2
13	O-ring	1
14	O-ring	1
15	Back-up Ring	1
16	Back-up Ring	1
17	Check Ball (1/4 in.)	1
18	Check Ball Spring	1
19	Elbow Fitting	1
22	Shim	A.R.

NSS- NOT SERVICED SEPARATELY - REPLACE COMPLETE VALVE ASSEMBLY

1 1/2 INCH BRAKE VALVE

1 1/2 inch brake valves built after mid-March 1997 contain a spring seat (item 22 above) between the spool spring and the spool. This provides a slightly larger, more uniform area for the spring to seat against the spool. The result is increased spring service life and improved repeatability of the pressure/flow modulation over the full compression range of the spring.

The spring retainer has been modified to allow for the additional thickness of the spring seat and a groove ma-

chined into the hex end cap serves as a visual indicator that the valve contains the new spring seat. The spring seat improvement may be added to early brake valves by installing kit (Part No. 62805). Items 3, 7, 13, 14 & 22 shown above are included in the kit. We recommend that this kit be installed whenever the brake valve is removed for inspection or service.

It is always a good practice to check the initial opening or "cracking" pressure of the brake valve whenever the hoist is serviced or inspected. Refer to Braden Service Bulletin number 527 for complete brake valve test and adjustment procedures.

DISASSEMBLY

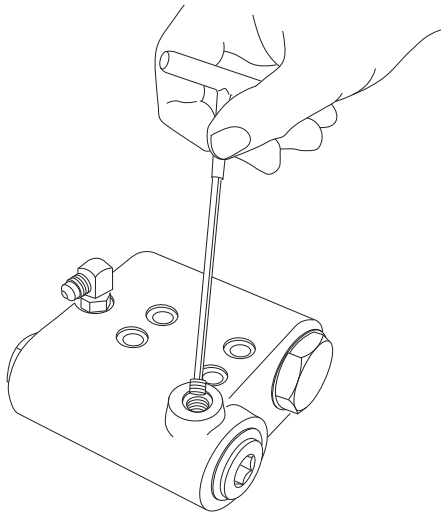

1. On the 1 1/4 in. valve only, remove the pilot orifice from the brake release (BR) port using a 5/32 in. Allen wrench.

1 1/4 in. valve

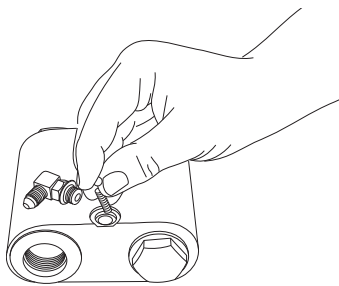

1 1/2 in. valve

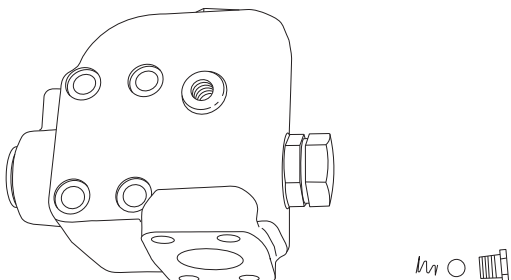

2. Remove the fitting, motor drain check ball and spring.

1 1/4 in. valve

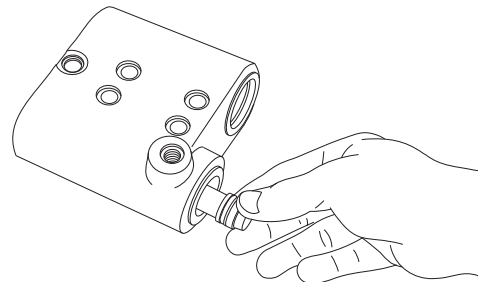

1 1/2 in. valve

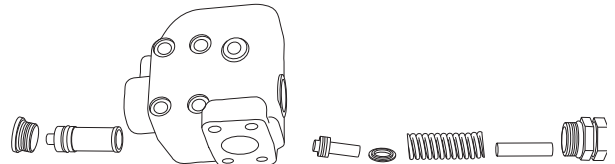

3. Remove the spool spring retainer and spool spring. Remove the spool plug and carefully remove the spool assembly. Remove the damper piston from the spool. The piston will come out of the spool slowly, because of a partial vacuum formed between the two. Use extreme care to avoid damaging the polished surfaces of either piece.

1 1/4 in. valve

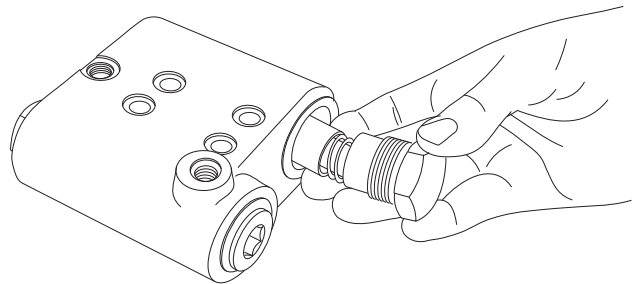

1 1/2 in. valve

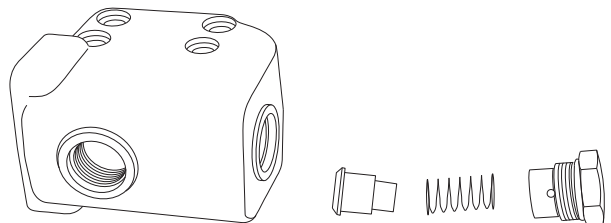

4. Remove the check valve spring retainer, spring and check valve poppet.

CLEAN AND INSPECT

1. Discard all O-rings and back-up rings. Clean all parts in solvent and blow dry. Inspect polished surfaces of spool and damper piston for damage that may cause

binding or leakage. Inspect spool bore in valve housing for damage or scoring. Inspect check valve seat in valve housing and check valve poppet. If the spools, bores or valves are damaged, the entire valve must be replaced as these parts are not serviced separately. Check the free length of the main piston spring. For the 1¼ inch valve, replace if less than 1 15/16 inches (49.2 mm) long. For the 1½ inch valve, replace if less than 3 7/16 inches (87.3 mm) long. Check the free length of the check valve spring. Replace if less than 1½ inches (38.1 mm) long.

1¼ in. valve

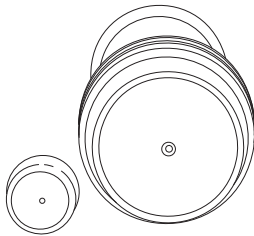

1½ in. valve

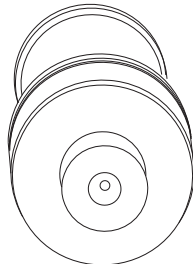

2. Inspect the 0.020 inch (0.5 mm) orifice in the end of the spool to be certain it is open. On the 1¼ in. valve, also inspect the pilot orifice to be certain it is open.

2. Install new O-rings and back-up rings on the spool and damper pistons as shown. It is important that each back-up ring is on the correct side of its O-ring. Take care not to cut the O-rings during assembly. Let the spool and piston set for ten minutes before installing them in their respective bores. This will allow the O-rings to return to their original size after being stretched.

1¼ in. valve

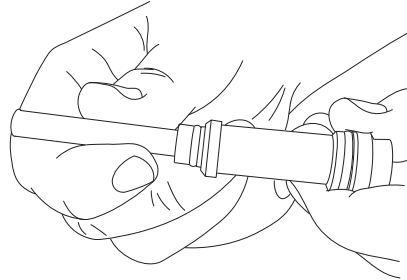

1½ in. valve

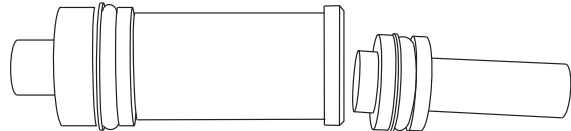

3. Lubricate the spool and damper piston O-rings with hydraulic oil. Carefully install the damper piston into the spool. Carefully install the spool into the valve housing. On either valve, always install the spool into the valve body so the O-ring enters the bore first, or the plug end of the valve body. Install the plug. On the 1¼ in. valve, install the spool spring and spring retainer. On the 1½ in. valve, install the spring seat, spool spring, damper piston extension and spring retainer.

ASSEMBLY

1. Install new O-rings on the plug and spool retainers.

1¼ in. valve

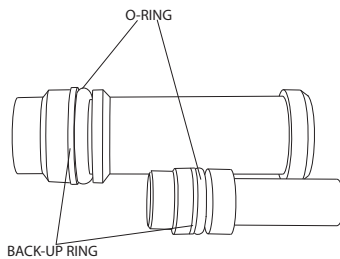

1½ in. valve

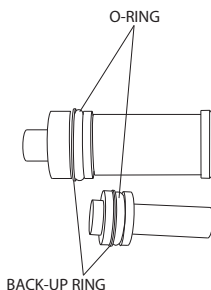

4. Install the check valve poppet, spring and check valve spring retainer.
 5. Install the motor drain check ball, spring and fitting.
 6. On the 1¼ in. valve only, install the pilot orifice into the BR port on the valve housing.
 7. The brake valve is now complete and ready to be installed on the hoist motor.



Authorized Distributor:
Pacific Marine & Industrial
 www.pacificmarine.net
 info@pacificmarine.net

RECOMMENDED FASTENER TORQUE

The general purpose torque shown in the chart applies to SAE Grade 5 bolts, studs and standard steel full, thick and high nuts.

Higher or lower torques for special applications will be specified such as the use of spanner nuts, nuts on shaft ends, jam nuts and where distortion of parts or gaskets is critical.

Lubricated torque values based on use of SAE 30wt engine oil applied to threads and face of bolt or nut.

Avoid using thread lubricants as the applied torque may vary by 10-40% depending upon product used.

Bolt Dia. Inches	Thds Per Inch	Torque (LB-FT)			
		Grade 5		Grade 8	
		Dry	Lubed	Dry	Lubed
1/4	20	8	6	12	9
	28				
5/16	18	17	13	24	18
	24				
3/8	16	31	23	45	35
	24				
7/16	14	50	35	70	50
	20				
1/2	13	75	55	110	80
	20				
9/16	12	110	80	150	110
	18				
5/8	11	150	115	210	160
	18				

Bolt Dia. Inches	Thds Per Inch	Torque (LB-FT)			
		Grade 5		Grade 8	
		Dry	Lubed	Dry	Lubed
3/4	10	265	200	380	280
	16				
7/8	9	420	325	600	450
	14				
1	8	640	485	910	680
	14				
1 1/8	7	790	590	1290	970
	12				
1 1/4	7	1120	835	1820	1360
	12				
1 3/8	6	1460	1095	2385	1790
	12				
1 1/2	6	1940	1460	3160	2370
	12				

To convert lb. ft. to kg-m, multiply lb. ft. value by 0.1383.



Authorized Distributor:
Pacific Marine & Industrial
www.pacificmarine.net
info@pacificmarine.net

METRIC CONVERSION TABLE

English to Metric

Metric to English

LINEAR					
inches (in.)	X 25.4	= millimeters (mm)	millimeters (mm)	X 0.3937	= inches (in.)
feet (ft.)	X 0.3048	= meters (m)	meters (m)	X 3.281	= feet (ft.)
miles (mi.)	X 1.6093	= kilometers (km)	kilometers (km)	X 0.6214	= miles (mi.)
AREA					
inches ² (sq.in.)	X 645.15	= millimeters ² (mm ²)	millimeters ² (mm ²)	X 0.000155	= inches ² (sq.in.)
feet ² (sq.ft.)	X 0.0929	= meters ² (m ²)	meters ² (m ²)	X 10.764	= feet ² (sq.ft.)
VOLUME					
inches ³ (cu.in.)	X 0.01639	= liters (l)	liters (l)	X 61.024	= inches ³ (cu.in.)
quarts (qts.)	X 0.94635	= liters (l)	liters (l)	X 1.0567	= quarts (qts.)
gallons (gal.)	X 3.7854	= liters (l)	liters (l)	X 0.2642	= gallon (gal.)
inches ³ (cu.in.)	X 16.39	= centimeters ³ (cc)	centimeters ³ (cc)	X 0.06102	= inches ³ (cu.in.)
feet ³ (cu.ft.)	X 28.317	= liters (l)	liters (l)	X 0.03531	= feet ³ (cu.ft.)
feet ³ (cu.ft.)	X 0.02832	= meters ³ (m ³)	meters ³ (m ³)	X 35.315	= feet ³ (cu.ft.)
fluid ounce (fl.oz.)	X 29.57	= milliliters (ml)	milliliters (ml)	X 0.03381	= fluid ounce (fl.oz.)
MASS					
ounces (oz.)	X 28.35	= grams (g)	grams (g)	X 0.03527	= ounces (oz.)
pounds (lbs.)	X 0.4536	= kilograms (kg)	kilograms (kg)	X 2.2046	= pounds (lbs.)
tons (2000 lbs.)	X 907.18	= kilograms (kg)	kilograms (kg)	X 0.001102	= tons (2000 lbs.)
tons (2000 lbs.)	X 0.90718	= metric tons (t)	metric tons (t)	X 1.1023	= tons (2000 lbs.)
tons (long) (2240 lbs.)	X 1013.05	= kilograms (kg)	kilograms (kg)	X 0.000984	= tons (long) (2240 lbs.)
PRESSURE					
inches Hg (60°F)	X 3600	= kilopascals (kPa)	kilopascals (kPa)	X 0.2961	= inches Hg (60°F)
pounds/sq.in. (PSI)	X 6.895	= kilopascals (kPa)	kilopascals (kPa)	X 0.145	= pounds/sq.in. (PSI)
pounds/sq.in. (PSI)	X 0.0703	= kilograms/sq.cm. (kg/cm ²)	kilograms/sq.cm. (kg/cm ²)	X 14.22	= pounds/sq.in. (PSI)
pounds/sq.in. (PSI)	X 0.069	= bars	bars	X 14.5	= pounds/sq.in. (PSI)
inches H ₂ O (60°F)	X 0.2488	= kilopascals (kPa)	kilopascals (kPa)	X 4.0193	= inches H ₂ O (60°F)
bars	X 100	= kilopascals (kPa)	kilopascals (kPa)	X 0.01	= bars
POWER					
horsepower (hp)	X 0.746	= kilowatts (kW)	kilowatts (kW)	X 1.34	= horsepower (hp)
ft.-lbs./min.	X 0.0226	= watts (W)	watts (W)	X 44.25	= ft.-lbs./min.
TORQUE					
pound-inches (in.-lbs.)	X 0.11298	= newton-meters (N-m)	newton-meters (N-m)	X 8.851	= pound-inches (in.-lbs.)
pound-feet (ft.-lbs.)	X 1.3558	= newton-meters (N-m)	newton-meters (N-m)	X 0.7376	= pound-feet (ft.-lbs.)
pound-feet (ft.-lbs.)	X .1383	= kilograms/meter (kg-m)	kilogram/meter (kg-m)	X 7.233	= pound-feet (ft.-lbs.)
VELOCITY					
miles/hour (m/h)	X 0.11298	= kilometers/hour (km/hr)	kilometers/hour (km/hr)	X 0.6214	= miles/hour (m/h)
feet/second (ft./sec.)	X 0.3048	= meter/second (m/s)	meters/second (m/s)	X 3.281	= feet/second (ft./sec.)
feet/minute (ft./min.)	X 0.3048	= meter/minute (m/min)	meters/minute (m/min)	X 3.281	= feet/minute (ft./min.)
TEMPERATURE					
°Celsius = 0.556 (°F - 32)			°Fahrenheit = (1.8 X °C) + 32		
COMMON METRIC PREFIXES					
mega	(M)	= 1,000,000 or 10 ⁶	deci	(d)	= 0.1 or 10 ⁻¹
kilo	(k)	= 1,000 or 10 ³	centi	(c)	= 0.01 or 10 ⁻²
hecto	(h)	= 100 or 10 ²	milli	(m)	= 0.001 or 10 ⁻³
deka	(da)	= 10 or 10 ¹	micro	(µ)	= 0.000.001 or 10 ⁻⁶