

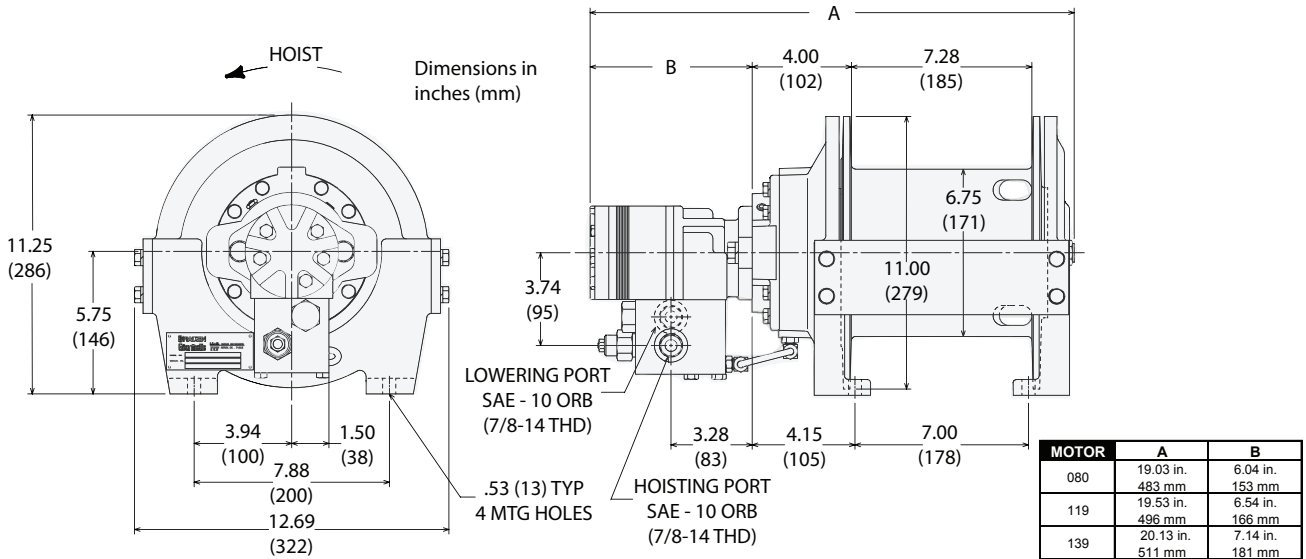

Authorized Distributor:
Pacific Marine & Industrial
www.pacificmarine.net
info@pacificmarine.net

BRADEN

MODEL BG4B UP TO 5,000-POUND LINEPULL



• 5,000 lbs. First Layer

• Multi-disc Spring

• High Efficiency Motor

Specifi

BG4B-05080-01

8.0 cu in. Motor (131cc)
2524PSI (171 bar) @ 15 gpm (57 lpm)
Wire Rope Diameter: 3/8"

	LINE PULL		LINE SPEED		ROPE CAPACITY	
	LB	KG	FPM	MPM	FT	M
1	3,000	1,364	145	44	36	11
2	2,710	1,232	160	49	76	23
3	2,480	1,127	176	54	119	36
4	2,280	1,036	191	58	166	51
5*	2,110	959	206	63	217	66

* Layer does not meet ANSI B30.7

BG4B-05119-01

11.9 cu in. Motor (195cc)
2263PSI (156 bar) @ 20 gpm (76 lpm)
Wire Rope Diameter: 3/8"

	LINE PULL		LINE SPEED		ROPE CAPACITY	
	LB	KG	FPM	MPM	FT	M
1	4,000	1,818	133	41	36	11
2	3,620	1,645	148	45	76	23
3	3,300	1,500	162	49	119	36
4	3,040	1,382	176	54	166	51
5*	2,810	1,277	190	58	217	66

* Layer does not meet ANSI B30.7

BG4B-05139-01H

13.9 cu in. Motor (228cc)
2422PSI (167 bar) @ 20 gpm (76 lpm)
Wire Rope Diameter: 3/8"

	LINE PULL		LINE SPEED		ROPE CAPACITY	
	LB	KG	FPM	MPM	FT	M
1	5,000	2,273	114	35	36	11
2	4,520	2,055	126	38	76	23
3	4,130	1,877	138	42	119	36
4	3,800	1,727	150	46	166	51
5*	3,520	1,600	162	49	217	66

* Layer does not meet ANSI B30.7

Wire Rope Storage Capacities

BG4B & BG4B-01H DRUM CAPACITY (6.75" B x 11.00" F x 7.28" W)								
	D/d	1	2	3	4	5	6	7
1/4 in.	28.1	53	110	170	234	302	374	450*
6 mm		16	34	52	71	92	114	137*
3/8 in.	19:1	36	76	119	166	217*		
10 mm		11	23	36	51	66*		
7/16 in.	16:1	31	66	104	146*			
11 mm		9.4	20	32	45*			

* Layer does not meet ANSI B30.7

LIT2307 R3 9-2009

PACCAR
WINCH DIVISION

MAKERS OF THE FINEST WINCH, HOIST, AND DRIVE SYSTEMS