

BRADEN®

PD7C

MATERIAL LIST

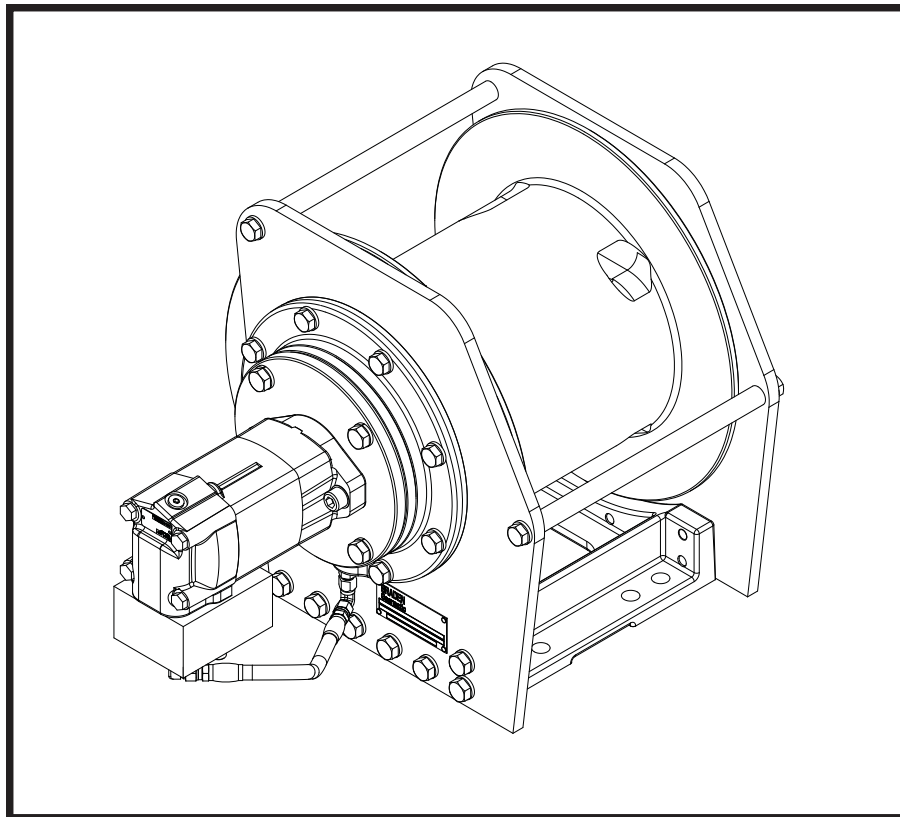

Authorized Distributor:
Pacific Marine & Industrial
www.pacificmarine.net
info@pacificmarine.net

LIT-2422 R2
12/2008
Printed in U.S.A.

Pacific Marine & Industrial - www.pacificmarine.net

PACCAR WINCH DIVISION
P.O. Box 547 Broken Arrow, Oklahoma 74013
PHONE: (918) 851-8511 FAX: (918) 259-1575
www.paccarwinch.com

Copyright 2008 PACCAR Winch Division
All Rights Reserved.



FORWARD

Read and understand the entire publication before operating or servicing your BRADEN Drive. Retain this manual for future reference.

The following service illustrations have been prepared to provide assembly, disassembly and maintenance information for the drive units covered in this publication. It is suggested that before doing any work on these units, all assembly and disassembly instructions should be read and understood.

Some illustrations in this manual may show details or attachments which may be differed from your drive. Also, some components may be removed for illustrative purposes.

Continuing product improvement may cause changes in your unit which may not be included in this manual. When a question arises regarding your unit or this manual, contact your nearest BRADEN/GEARMATIC dealer or the factory Service Department at 918-251-8511, Monday - Friday, inquiries.

EXPLANATION OF MODEL NUMBER



- PD** DESIGNATES PLANETARY DRIVE
- 7** DESIGNATES 7,000 LB FIRST LAYER LINE PULL
- C** DESIGNATES THE MODEL SERIES RELATING TO DESIGN CHANGES
- 07** DESIGNATES TOTAL GEAR RATIO (7:1)
- 120** DESIGNATES MOTOR DISPLACEMENT
- 01** DESIGNATES THE DRUM OPTION

OIL CAPACITIES

Consult factory for current oil capacities.

RECOMMENDED PLANETARY GEAR OIL

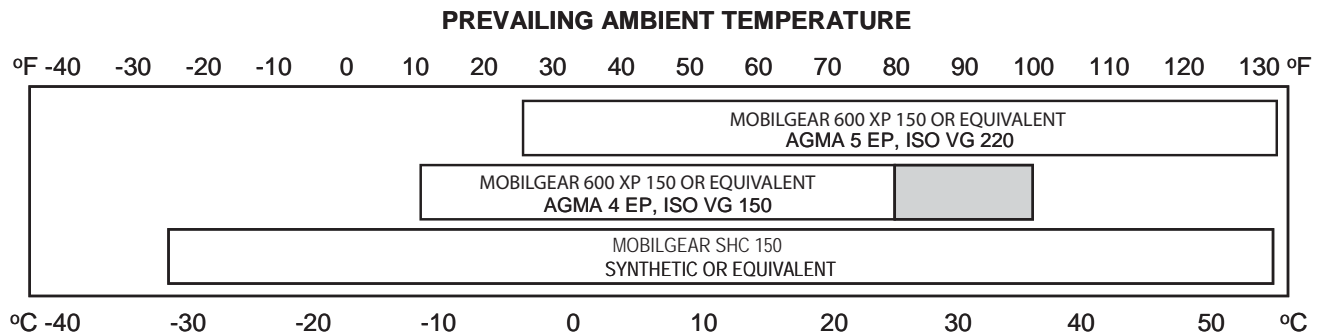

NOTE: SHADED TEMPERATURE RANGE IN THE CHART ABOVE NOT RECOMMENDED FOR SEVERE APPLICATIONS SUCH AS: OFFSHORE CRANES, SUSTAINED FAST DUTY CYCLES OR FREQUENT LIFTING.

Planetary hoists are factory filled with Mobilgear 600 XP 150, or equivalent. Consult your oil supplier for other equivalent oils if required.

Mobil	Shell	Chevron	Texaco
Mobilgear 600 XP 150	Omala 150	Gear Compounds EP 150	Meropa 150
Mobilgear 600 XP 220	Omala 220	Gear Compounds EP 220	Meropa 220



MISCELLANEOUS PARTS GROUP

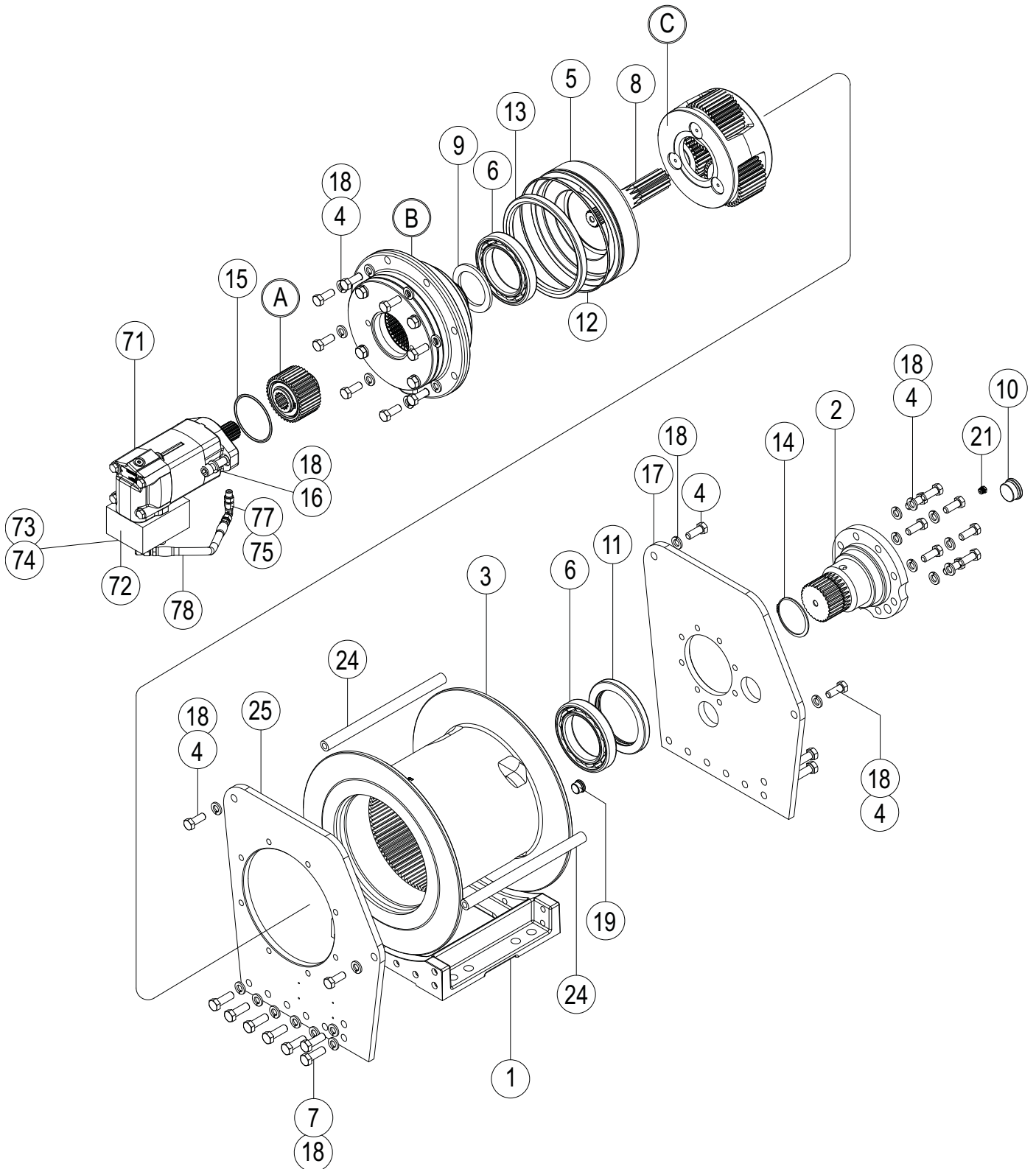



MISCELLANEOUS PARTS GROUP

ITEM	DESCRIPTION	PART NO. 12.0 Motor 01 Drum	PART NO. 24.0 Motor 01 Drum	PART NO. 15.0 Motor 02 Drum	PART NO. 19.0 Motor 02 Drum	QTY
1	Base	104521	104521	107114	107114	1
2	Bearing Support	104585	104585	104585	104585	1
3	Cable Drum	107134	104517	107102	107102	1
4	Capscrew (1/2 - 13 X 1 1/4 GD8)	104174	104174	104174	104174	20
5	Cable Drum Closure	26763	26763	26763	26763	1
6	Ball Bearing	24110	24110	24110	24110	2
7	Capscrew (1/2 - 13 X 1 1/2 GD8)	103314	103314	103314	103314	14
8	Sun Gear	104592	104592	104592	104592	1
9	Thrust Washer	40128	40128	40128	40128	1
10	Plug	24420	24420	24420	24420	1
11	Oil Seal	106190	24109	24109	24109	1
12	O-Ring	21033	21033	21033	21033	1
13	Oil Seal	22818	22818	22818	22818	1
14	Retaining Ring, External	70575	70575	70575	70575	1
15	O-Ring	22586	22586	22586	22586	1
16	Capscrew (1/2 - 13 X 1 1/2 GD8) (NS)	21908	21908	21908	21908	2
17	Side Plate, Support	107104	104594	107112	107112	1
18	Lockwasher (1/2)	11026	11026	11026	11026	36
19	Plug, O-Ring Flush	32411	32411	32411	32411	1
20	Cable Wedge (NS)	74780	74780	74780	74780	1
21	Relief Valve	18062	18062	18062	18062	1
22	Nameplate (NS)	76381	76381	76381	76381	1
23	Drive Screw (NS)	11842	11842	11842	11842	4
24	Spacer	104596	104596	104596	104596	2
25	Side Plate, Motor	107105	104595	107113	107113	1
26	Sensor Wheel (NS)	106191	---	---	---	1
71	Motor	107115	107136	B688P	104591	1
72	Brake Valve	107130	107348	107348	107348	1
73	Capscrew (NS)	25622	13587	13587	13587	3
74	Hex Head Plug (NS)	25663	25663	25663	25663	1
75	Elbow Fitting (NS)	25302	25302	25302	25302	1
76	Adapter (NS)	25864	25864	25864	25864	1
77	Swivel Nut	26140	26140	26140	26140	1
78	Hose Assy	25936	25936	25936	25936	1
79	Shipping Plug (NS)	29965	29965	29965	29965	2



SPRAG CLUTCH ASSEMBLY

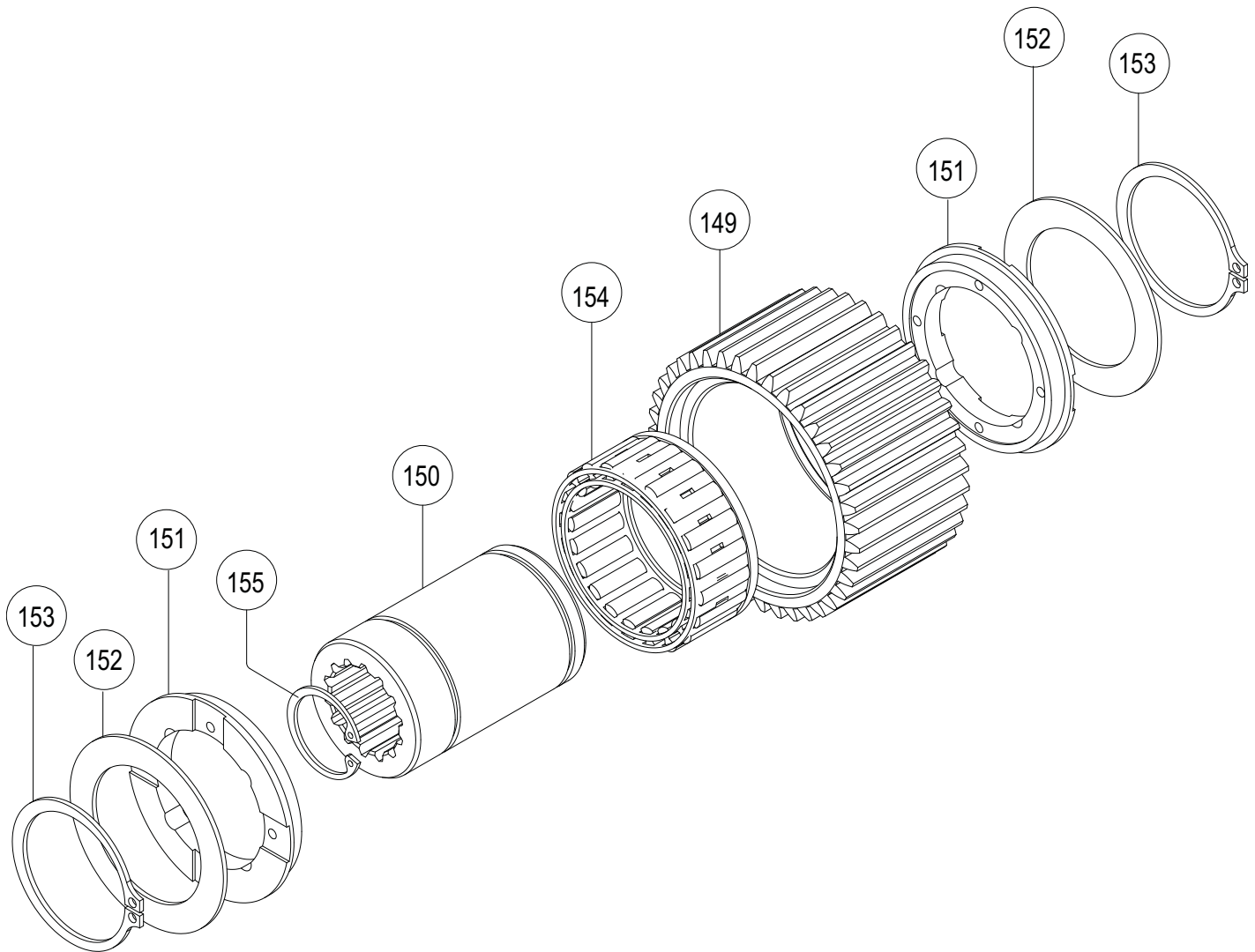

ITEM	DESCRIPTION	PART	QTY
149	Outer Brake Race	NSS	1
150	Inner Brake Race	NSS	1
151	Sprag Bearing	27684	2
152	Thrust Bearing	24581	2
153	Snap Ring	12034	2
154	Sprag Clutch	NSS	1
155	Retaining Ring	24506	1

NSS- Not Serviced Separately



BRAKE CYLINDER ASSEMBLY

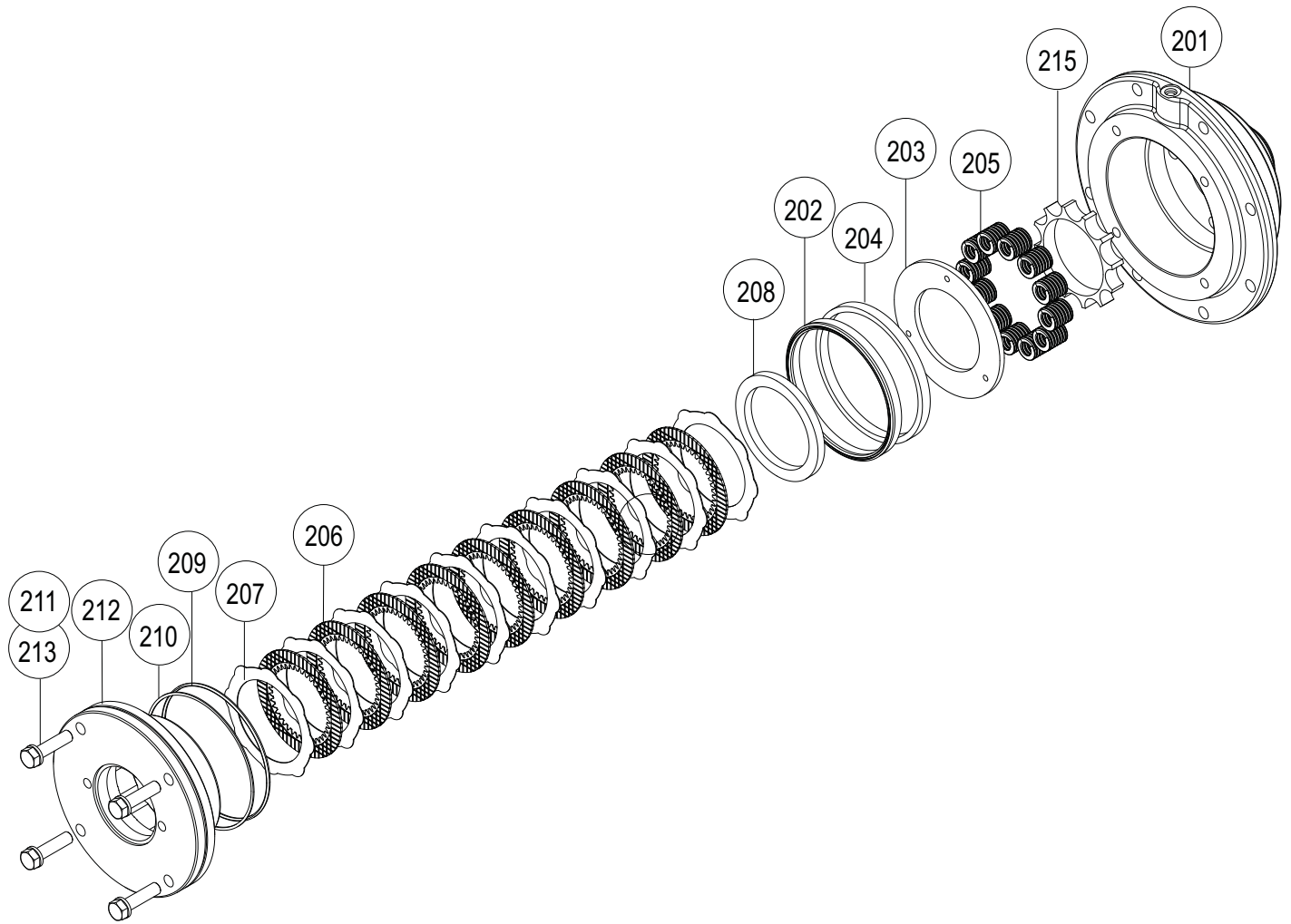

ITEM	DESCRIPTION	PART	QTY
201	Brake Cylinder	100035	1
202	Seal	25642	1
203	Pressure Plate Stamping	25635	1
205	Die Spring	25644	12
206	Disc Friction	21036	9
207	Brake Disk	100027	10
204	Piston Backup Ring	25636	1
208	Spacer	25637	1
209	O-Ring	24981	1
210	Back-up Ring	25643	1
211	Capscrew (1/2 - 13 X 2 GD8)	29855	4
212	Motor Support	104593	1
213	Lockwasher (1/2)	11026	4
214	Shipping Plug Hyd (NS)	25403	1
215	Spring Spacer	100200	1



OUTPUT PLANET CARRIER ASSEMBLY

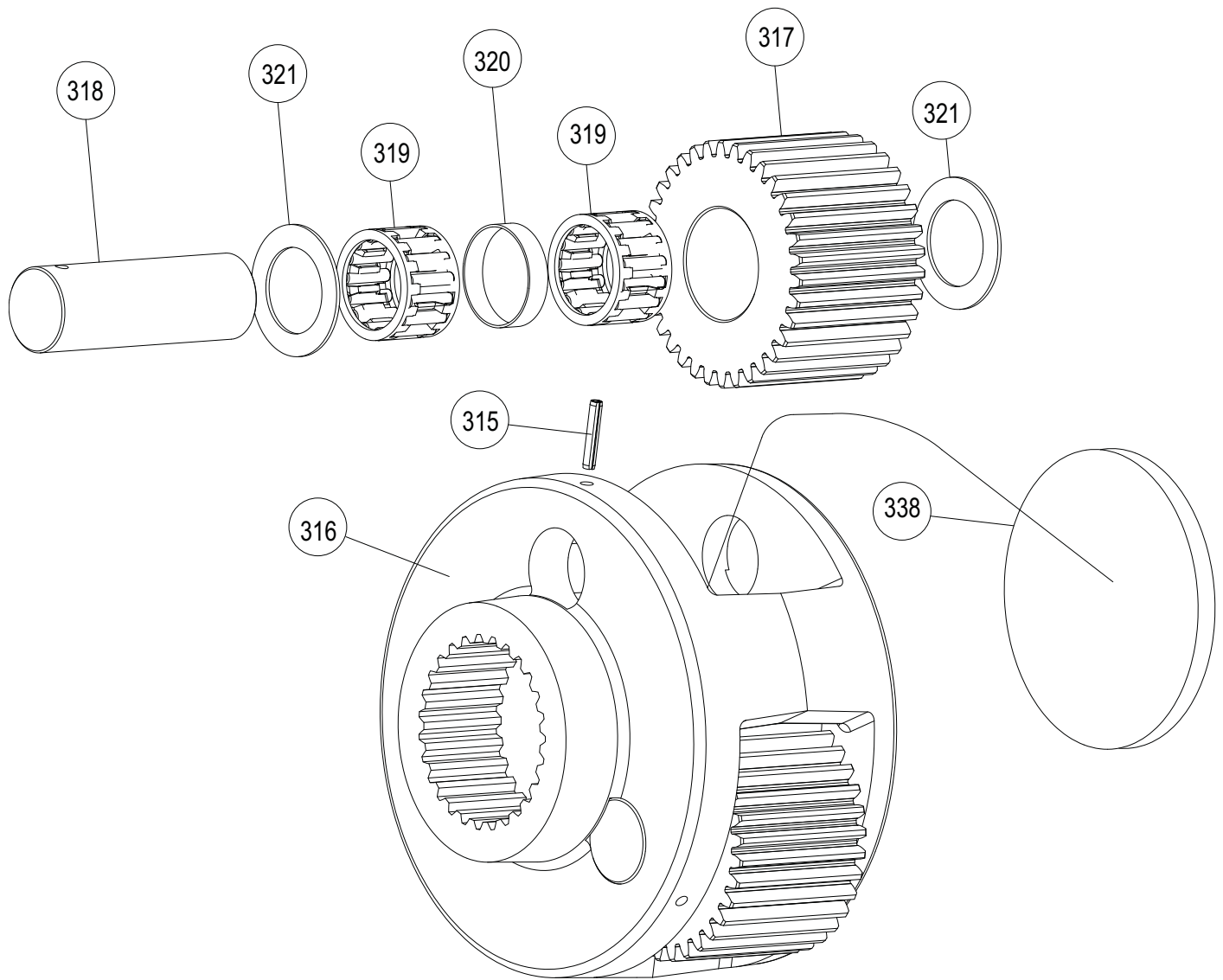

ITEM	DESCRIPTION	PART	QTY
315	Pin-Spirol	23584	3
316	Output Planet Carrier	25562	1
317	Planet Gear	26277	3
318	Planet Gear Shaft	25613	3
319	Roller Bearing	25292	6
320	Bearing Spacer	25443	3
321	Thrust Washer	24306	6
338	Output Spacer	25638	1



METRIC CONVERSION TABLE

English to Metric			Metric to English		
LINEAR					
inches (in.)	X 25.4	= millimeters (mm)	millimeters (mm)	X 0.3937	= inches (in.)
feet (ft.)	X 0.3048	= meters (m)	meters (m)	X 3.281	= feet (ft.)
miles (mi.)	X 1.6093	= kilometers (km)	kilometers (km)	X 0.6214	= miles (mi.)
AREA					
inches ² (sq.in.)	X 645.15	= millimeters ² (mm ²)	millimeters ² (mm ²)	X 0.000155	= inches ² (sq.in.)
feet ² (sq.ft.)	X 0.0929	= meters ² (m ²)	meters ² (m ²)	X 10.764	= feet ² (sq.ft.)
VOLUME					
inches ³ (cu.in.)	X 0.01639	= liters (l)	liters (l)	X 61.024	= inches ³ (cu.in.)
quarts (qts.)	X 0.94635	= liters (l)	liters (l)	X 1.0567	= quarts (qts.)
gallons (gal.)	X 3.7854	= liters (l)	liters (l)	X 0.2642	= gallon (gal.)
inches ³ (cu.in.)	X 16.39	= centimeters ³ (cc)	centimeters ³ (cc)	X 0.06102	= inches ³ (cu.in.)
feet ³ (cu.ft.)	X 28.317	= liters (l)	liters (l)	X 0.03531	= feet ³ (cu.ft.)
feet ³ (cu.ft.)	X 0.02832	= meters ³ (m ³)	meters ³ (m ³)	X 35.315	= feet ³ (cu.ft.)
fluid ounce (fl.oz.)	X 29.57	= milliliters (ml)	milliliters (ml)	X 0.03381	= fluid ounce (fl.oz.)
MASS					
ounces (oz.)	X 28.35	= grams (g)	grams (g)	X 0.03527	= ounces (oz.)
pounds (lbs.)	X 0.4536	= kilograms (kg)	kilograms (kg)	X 2.2046	= pounds (lbs.)
tons (2000 lbs.)	X 907.18	= kilograms (kg)	kilograms (kg)	X 0.001102	= tons (2000 lbs.)
tons (2000 lbs.)	X 0.90718	= metric tons (t)	metric tons (t)	X 1.1023	= tons (2000 lbs.)
tons (long) (2240 lbs.)	X 1013.05	= kilograms (kg)	kilograms (kg)	X 0.000984	= tons (long) (2240 lbs.)
PRESSURE					
inches Hg (60°F)	X 3600	= kilopascals (kPa)	kilopascals (kPa)	X 0.2961	= inches Hg (60°F)
pounds/sq.in. (PSI)	X 6.895	= kilopascals (kPa)	kilopascals (kPa)	X 0.145	= pounds/sq.in. (PSI)
pounds/sq.in. (PSI)	X 0.0703	= kilograms/sq.cm. (kg/cm ²)	kilograms/sq.cm. (kg/cm ²)	X 14.22	= pounds/sq.in. (PSI)
pounds/sq.in. (PSI)	X 0.069	= bars	bars	X 14.5	= pounds/sq.in. (PSI)
inches H ₂ O (60°F)	X 0.2488	= kilopascals (kPa)	kilopascals (kPa)	X 4.0193	= inches H ₂ O (60°F)
bars	X 100	= kilopascals (kPa)	kilopascals (kPa)	X 0.01	= bars
POWER					
horsepower (hp)	X 0.746	= kilowatts (kW)	kilowatts (kW)	X 1.34	= horsepower (hp)
ft.-lbs./min.	X 0.0226	= watts (W)	watts (W)	X 44.25	= ft.-lbs./min.
TORQUE					
pound-inches (in.-lbs.)	X 0.11298	= newton-meters (N-m)	newton-meters (N-m)	X 8.851	= pound-inches (in.-lbs.)
pound-feet (ft.-lbs.)	X 1.3558	= newton-meters (N-m)	newton-meters (N-m)	X 0.7376	= pound-feet (ft.-lbs.)
pound-feet (ft.-lbs.)	X .1383	= kilograms/meter (kg-m)	kilogram/meter (kg-m)	X 7.233	= pound-feet (ft.-lbs.)
VELOCITY					
miles/hour (m/h)	X 0.11298	= kilometers/hour (km/hr)	kilometers/hour (km/hr)	X 0.6214	= miles/hour (m/h)
feet/second (ft./sec.)	X 0.3048	= meter/second (m/s)	meters/second (m/s)	X 3.281	= feet/second (ft./sec.)
feet/minute (ft./min.)	X 0.3048	= meter/minute (m/min)	meters/minute (m/min)	X 3.281	= feet/minute (ft./min.)
TEMPERATURE					
°Celsius = 0.556 (°F - 32)			°Fahrenheit = (1.8°C) + 32		
COMMON METRIC PREFIXES					
mega	(M)	= 1,000,000 or 10 ⁶	deci	(d)	= 0.1 or 10 ⁻¹
kilo	(k)	= 1,000 or 10 ³	centi	(c)	= 0.01 or 10 ⁻²
hecto	(h)	= 100 or 10 ²	milli	(m)	= 0.001 or 10 ⁻³
deka	(da)	= 10 or 10 ¹	micro	(µ)	= 0.000.001 or 10 ⁻⁶