

MODEL PD17A

UP TO 17,500-POUND LINEPULL

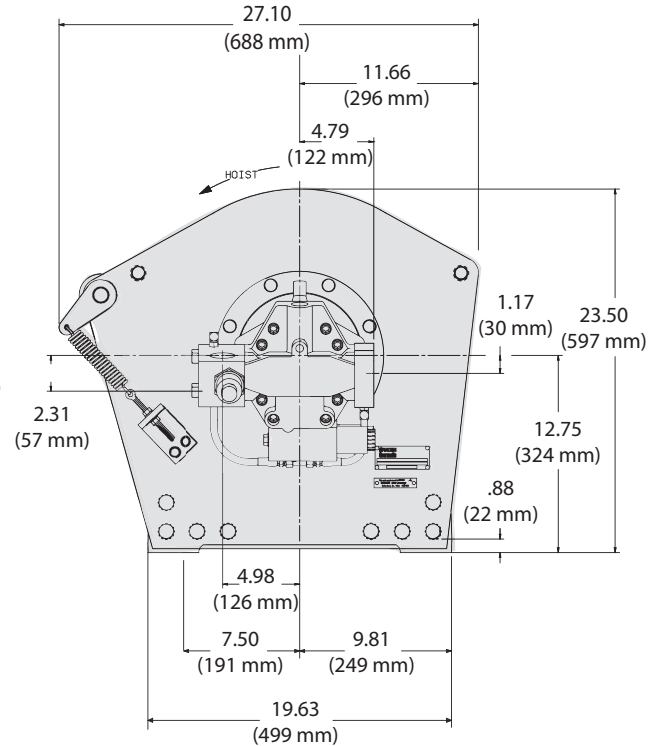
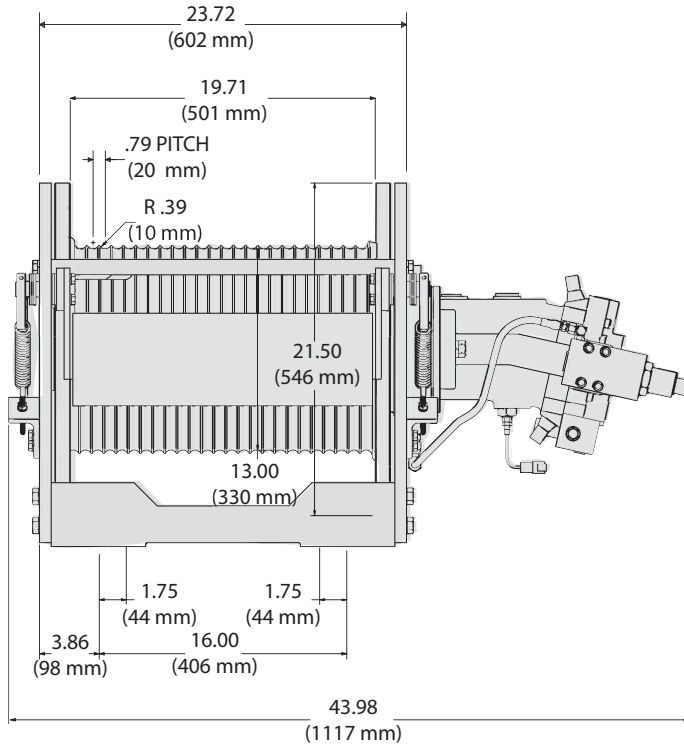

• 17,500 lbs. First Layer

• 47:1 Ratio

• Optional Free Fall

PD17A-47V065/032 - 27G

6.5 cu in. Motor (106 cc)
3210 PSI (221 bar) @ 50 gpm (189.2 lpm)
Wire Rope Diameter: 3/4"

	LINE PULL		LINE SPEED		ROPE CAPACITY	
	LB	KG	FPM	MPM	FT	M
1	17,500	7,938	127	39	91	28
2	15,780	7,187	141	43	192	59
3	14,360	6,513	155	47	304	93
4	13,180	5,978	169	52	426	130
5	12,180	5,524	182	55	558	170

PD17A-47V065/032 - 27G

3.2 cu in. Motor (52 cc)
3210 PSI (221 bar) @ 50 gpm (189.2 lpm)
Wire Rope Diameter: 3/4"

	LINE PULL		LINE SPEED		ROPE CAPACITY	
	LB	KG	FPM	MPM	FT	M
1	7,280	3,309	259	79	91	28
2	6,560	2,982	288	88	192	59
3	5,970	2,714	316	96	304	93
4	5,480	2,491	344	105	426	130
5	5,070	2,305	373	114	558	170